

# PROLOGUE: IS CURRENT SCIENCE INCOMPLETE?

What if everything you thought you knew about science, and its connection to spirituality, was wrong?

What if you woke up one day to discover that the entire nature and structure of the Universe had actually eluded all of mainstream science up until that moment? Could such a thing be possible?

How confident do you feel in the idea that atoms are made up of particles? Are you aware that even the most basic quantum physics is littered with solid experimental findings that totally defeat this idea and have heretofore defied all attempts at explanation? That the entire quantum realm of atoms and molecules can be built up from electromagnetic fields displaying simple properties of movement and geometry?

When someone mentions "higher dimensions," how much do you truly understand about what they are, where they are, and how they work? Do you have any idea about how they can intersect with our own reality?

Have you ever studied Chaos theory and fractals? Did you know that scientists have proven that apparently random or "chaotic" events, both in space and in time, are being "organized" by complex geometric patterns known as fractals? That the behavior of both weather processes and living creatures, including human beings, can be mapped by these fractals? That the fractals themselves can only be constructed by blending our typical positive and negative numbers with an axis of numbers that is "imaginary" or outside of our perceivable mathematical reality?

Has anyone truly explained why or how these principles are occurring?

When you see the reports of UFO sightings, are you puzzled as to how anything could defy gravity and make such sudden movements without destroying any living being inside? Do you discount the possibility that "they" could have visited us because of a belief that no mass can exceed the velocity of "c", the speed of light?

Was it a natural mistake for Einstein to assume that light couldn't travel faster than "c" if it was believed to be traveling through total empty space, free of any type of energy? If there is a tangible energy in space, then what would happen if light traveled through an area of "thinner" energy, vibrating at a higher frequency than the thickness of the energy that now surrounds us? Do you remember reading about experiments in 2000 that have demonstrated velocities up to 300 times faster than the speed of light?

Do you believe that we have to burn something to get energy? Have you ever heard of, or given any consideration to, the idea that limitless free energy can be harnessed from "empty" space? Are you aware that simply rotating a magnetic gyroscope can create free energy and anti-gravity effects at the same time?

Did you believe the mainstream media when the science of "cold fusion" was laughed at because it "violated the laws of chemistry and physics?" Are you aware that literally thousands of documented experiments are on record that have proven this effect since its discovery in the late 1980's?

Have you ever studied "sacred geometry?" Are you aware that the bodies of all living creatures must grow by these proportions? Did you know that these geometries are "harmonic," meaning that they have all the same mathematical and vibrational properties as music and color?

Could it be possible that this unseen harmonic energy is structuring all of physical space, including the spacings of the stars and planets and even the precise arrangement of continents on Planet Earth? Might these same forces also

exist in time, exerting a powerful effect on the behavior of human beings that can be concretely mapped out in the movement of financial markets?

If you know something about quantum physics, are you aware that the previously-undiscovered blueprints of this same harmonic geometry can be revealed in Planck's constant, the electromagnetic wave, the fine structure constant, the ratio of weak to strong force, the photon, the electron, valence bonds, isotopes and more?

Did you know that the atom can be built up entirely as a particle-free grouping of geometrically structured energy? That things such as the "spin" of quarks and electrons are actually showing us that these energies are traveling through a geometric matrix that underlies and forms all of our physical existence? That this geometry of space might explain the mysterious property known as "torsion" which means that "particles" traveling through "empty space" are forced to rotate as they travel?

Do you believe that there was a Big Bang, that "nothing" could explode to create the Universe? Are you aware that this theory is on its last legs, propped up with an ever-increasing number of excuses and assumptions and ready to collapse? Did you ever hear of the solid scientific evidence that can prove that the entire Universe looks exactly like a gigantic galaxy, complete with spiraling arms composed of galactic superclusters with very little in between them?

If the entire Universe has one fixed axis of rotation that can be calculated and measured, what does this do to relativity theory? Would this not be as important a discovery as seeing the Sun at the center of the Solar System, since Einstein's relativity theory asserts that "all motion is relative, and there is no stable, fixed place in the Universe" to measure motion from? What would this do to our ideas of time as well, since time is also believed to be relative by the same logic?

On a much more personal level, do you believe that every thought and influence in your mind is solely being created from within your own mind? Have you ever considered the idea that your consciousness is constantly being affected by forces outside of your own mind, body and physical surroundings?

Are you ready to survey the solid, factual information that will show you, possibly for the first time, that not all of your thoughts and actions are being dictated solely by your own conscious mind? That unseen cosmic forces can influence your state of mind quite directly? That these forces actually have precise geometric structures that have been mapped and analyzed, and whose effects can be predicted well in advance?

Do you believe that through philosophies and theories such as Laplace's "Logical Positivism" that science has "proven that God does not exist?" ***Are you prepared to view a concrete scientific case that an Ultimate Conscious Being does exist after all?***

Are you aware that all of these points and more can be explained elegantly and perfectly, by simply restoring the ancient idea that a fluidlike, non-physical energy, or "aether," exhibiting the simplest properties of vibration, exists throughout all of space and time and is creating all physical matter moment-by-moment?

Lastly, if you can accept the proof that a non-physical energy source exists, do you automatically assume that it will always have the same properties, such as density, wherever you look in the Universe?

Could it be possible that this energy could have changing densities throughout an area such as our galaxy? That these changing densities have a precise structure that our Solar System moves through in exact cycles of time? That we are now about to complete one of these cycles and move into an area of higher energetic "density?" That all

bodies in our Solar System, including the Earth and the Sun, are being dramatically and visibly affected by this ever-increasing energy?

You will then see how perfectly this idea explains a multitude of solid, empirical astrophysical observations, some known and some unknown, some very modern and some very ancient, that are now indicating that we have arrived at a key point of transformation in our immediate future; both physical and spiritual.

## THE COSMIC CHESS GAME

Imagine for a moment that the deepest truths of the Universe were all contained in a game of chess, and we had to play the game in order to discover the secrets. In the deepest sense of truth, there is a set playing field, and there are set pieces with set laws that define their movements. As Einstein said, “God is subtle but not devious ” and “God does not play dice, ” meaning that the “game ” should ultimately be straightforward, and based on set rules.

Now, imagine what it would be like to try to play this game with a hidden companion if you could only see four of the squares, even though the board ultimately has 64 spaces. You could only know about a maximum of four different pieces, (in the case of chess there are six types, each with separate rules of movement,) and you may or may not be aware that your pieces could even move.

If you could only see four spaces, then you might naturally conclude that your pieces couldn't go anywhere; they were fixed and immobile.



Over time, you may have the insight to discover that you can move certain pieces out into other parts of the board, even though you couldn't directly see those parts, and then move them safely back to square one. (Columbus proved to the world that you could sail east across the Atlantic Ocean and not drop off of the “edge of the earth. ”)

Then, with this new discovery you might believe that you should eventually be able to determine the full nature of the playing field. But still, if an outside intelligence is controlling other pieces that you cannot see and can thereby remove your own pieces, then it would be very difficult to map out the playing field; not all of your pieces would be able to return.

You might not even be aware that you were playing the game with someone else, that there were other pieces that existed, and that those pieces may behave according to set laws that you are completely unfamiliar with. Furthermore, you may be quite shocked when your hidden companion's pieces suddenly appear on one of your four squares, change the entire setup by removing one of your pieces, and then disappear in the next instant.

If you have studied the rules of chess, you would know that it would ultimately be impossible to know how all six types of pieces would function if you only had access to four pieces and could visually perceive four squares.

It would be quite a paradigm shift to realize that you had twelve other pieces out there to play with! The pawn, knight, bishop, rook, Queen and King all have completely different rules of movement, and you could not understand how they work if you could only see their behavior in that limited "box. "

Like it or not, this cosmic chess game is an apt metaphor for the struggles that we have faced in understanding our universe on every level of complexity. As we will show in this book, quantum physics is already at a stalemate of "uncertainty " and "non-locality. " Our scientists have made extraordinarily precise measurements of the quantum realm, but they have been unable to explain those measurements for arguably more than fifty years.

Therefore, we are told that we have subatomic entities that are both particles and waves at the same time - and these are two very different things. Many physicists have essentially thrown up their hands and concluded that once we enter the realm of the very small, logic no longer applies. This has even been codified into a school of philosophy in its own right, known as the Copenhagen Doctrine, which states that mathematics is the only way to understand the quantum realm and it is useless and needless to try to explain the measurements in any other way.

And we now know that this is simply not true.

As we shall explore in Chapter 18 of this book, all of our evidence about the subatomic plane has been gathered indirectly - we have never been able to visually photograph protons, neutrons and electrons. Therefore, any conclusion that we make will be indirect; it is up to us to decide what model is best, meaning the model that will explain the observed measurements and data most comfortably. And considering that all of visible reality is built up from the quantum realm, if there truly is a "hidden variable " that the physicists have missed, then perhaps our view of "reality " would suddenly be very different.

To put it a different way, our scientists have collected all of their measurements very well, but we propose that they have overlooked some very fundamental properties that these measurements demonstrate. When these properties are reintroduced into the mix, then suddenly all the paradoxes are resolved and the Copenhagen Doctrine is no longer necessary; we have a working model of the quantum realm that explains all of our measurements. If correct, this model will prove the penultimate importance of "sacred geometry " once and for all.

Furthermore, our observations of astrophysical phenomena contain a host of assumptions as well, and we have never bothered to question them. We automatically assume that a phenomenon known as "redshift " will measure how far away a given star or galaxy might be, and yet renowned astronomer Dr. Halton Arp has, though quite unpopularly, proven that this cannot be true. And even though we can only definitively observe the area around our

own Solar System with physical instruments such as the Voyager II satellite probe, we have drawn conclusions such as the idea that the speed of light is a constant throughout the known universe.

And most importantly, we have concluded that “empty space is empty ” and nothing exists there.

Another major bone of contention for the mainstream is “Global Expansion Tectonics, ” the scientific concept that the Earth is continually expanding in size. It just so happens that the entire “continental drift ” or “Plate Tectonics ” model cannot be proven correct; there are supposed to be many areas called “subduction zones ” where crust under the ocean is pushed back into the mantle and dissolved.

The problem is that there is no way to concretely prove that a subduction zone exists anywhere, and the areas that weigh in as “maybes ” are far fewer than the model requires. And if we look at the Earth itself, we can quickly see that all of the continents will fit perfectly together like a jigsaw puzzle, providing that the Earth is 55 to 60 percent smaller than it is now.

Other bodies in our Solar System, such as Jupiter’s moon Ganymede, provide simple, uncontested visual evidence that they are expanding from within. As we shall see later, the pictures of Ganymede look no different than if we had taken a balloon, inflated it halfway, covered it with mud, let the mud dry and then inflated it the rest of the way, so that the pieces of mud cracked apart into separate areas spread out on the balloon’s surface.

There is no way to explain these ideas scientifically if the quantum realm is only built up from “particles ” and we do not have an aether model in place, and thus the mainstream is very quick to put them down.

On an even deeper level, many people are not aware that there seems to be an “outside intelligence ” at work in the quantum playing field. Numerous findings have suggested that the outcome of an experiment is determined by what the observer expects to see. Do we truly profess to understand how this could be happening? No.

## **RESOLUTION**

In this book, we will propose a unified model that will answer this question and many others that have remained unresolved. We do not need to continue to play this blindfolded stalemate chess game on four squares, whether it be the structure of the quantum world or the structure of the Universe. Though it is controversial, there are sources of information that do allow us to know the playing field, and even perhaps to identify our partner in the game.

What we are left with is a framework of knowledge that explains much more about our physical reality than we have ever had access to before. And that fact alone should generate much attention, as more and more people become aware that this book that you are now reading is available to the public.

Normally, when someone makes as many new findings as our contributors have made in this book, it is written in a highly academic, concise format that excludes the majority of readers immediately. The interesting fact that makes this book different is that it is specifically written to be easy to understand, which is certainly an ideal method of presenting this information to the public at large. If it were written only to please scientists then it would quickly fade into obscurity, as do most other frontier scientific breakthroughs.

And so, this is not a book of fantasy or science fiction. This is a book that could not have been written until now, with the power of the Internet to bring the world’s frontier researchers together so that such a collaboration could take

place. Not simply another piece of the puzzle, it is an assembly of the puzzle: the first of its kind, fusing vast amounts of data together to reconstruct the Universe in a new “hyperdimensional ” model that is precisely unified from the quantum all the way up to the universe itself, and written at a level that does not exclude any readers with technical gibberish.

It is also the story of a discrete astrophysical event in our near future that we have labeled as “The Time of Global Shift, ” since it seems to have direct spiritual implications for humanity - the long-awaited shift from the Age of Pisces into the Age of Aquarius.

## CHAPTER 01: INTRODUCTION

### 1.1 THE SHIFT OF THE AGES

Virtually all world religions, spiritual faiths, secret societies and indigenous shamanic teachings insist that humanity is about to make a spontaneous, unprecedented stride in its material and spiritual development - a literal transformation of matter, energy and consciousness on all levels.

Since many of the cultures or groups proffering this information over thousands of years' time did not appear to have any direct contact with each other, (such as the Early Christians, the aborigines in Australia and the indigenous peoples of Mesoamerica,) we have to wonder how they all came to the same understanding.

If we take their own accounts on face value, it appears that entities that had attained a higher level of consciousness (such as Jesus, Buddha, Mohammed, Krishna, Viracocha and others) have systematically taught this information to all who would listen. Some ancient cultures, such as the Aztecs and Mayas, even have highly detailed calendar systems that appear to have precisely charted when this event will occur - sometime on or before Dec. 22, 2012.

In the hands of conventional science, this universally anticipated spiritual event is nothing more than an interesting myth with little or no real significance. However, with the material presented in this book, we can now make a direct scientific case for the imminent reality of this event. In order to do this, we must completely tear down the existing “particle ” model of physical science and fundamentally rebuild the nature, character and underlying structure of the Universe from the quantum to galactic level, using “new ” principles that have actually been known for thousands of years.

With these recently re-discovered scientific breakthroughs, we understand that there truly is no “empty space ” in the Universe - the entire Cosmos is filled with a hidden, flowing, geometric energy matrix commonly called “zero-point energy ” or “aether ” that is the source of all things, including life, and is therefore alive in its own right.

With this matrix, all elements of the Cosmos are very intimately and directly connected through “synchronicity ” as defined by Dr. Carl Jung, who said that every event in a particular space and time is fundamentally connected to every other event in that space and time. Concepts of “aether ” that were once considered unbridled “Dark Ages ” mysticism are now returning as an intrinsic aspect of the functioning of the Universe.

Some of the fundamental pieces of the puzzle, such as chaos and superstring theory, have actually penetrated into the mainstream already. Indeed, the full identification, exploration and scope of this conscious, multi-dimensional energy matrix, its identity as an Ultimate Being and precisely how it will produce such an event of religious proportions, is the purpose of this book.

## **1.2 MORE MATERIAL WAS NECESSARY**

Our first complete book that discusses this new paradigm of science and consciousness is entitled *The Shift of the Ages*, and it is now published freely at our website. Although we had originally and quite proudly considered this book to be our final statement on the subject, we subsequently realized that it could go much, much farther with additional research, and that an entirely new book was necessary to properly round out the model.

We will be referring the reader back to certain chapters in *The Shift of the Ages* in order to reduce the size of the manuscript and to avoid having to rewrite material that has already been covered to the best of our ability. While reviewing these earlier chapters will not be essential to understanding this book, they will allow the reader to cross-reference information that will be covered much more briefly in this edition.

## **1.3 COPERNICAN SCIENCE**

Obviously, many of the points that we will make in this book fly directly in the face of our mainstream scientific understanding. More and more frontier researchers are discovering that our current scientific Establishment has become akin to a religion in and of itself, where theories that were taught one or more generations in the past have become so institutionalized that any differing opinions are rarely given a hearing of any kind.

For anyone who has ever attended a university and built an entire career around one or a series of “pet theories,” any definitive evidence that smashes these theories can be utterly shocking and even deeply wounding. Though a non-scientific reader may laugh at the thought of it, when these “paradigm shocks” suddenly explode into view with the arresting finality of Truth, they can literally produce tears, dizziness and nausea in one who has dedicated his or her entire life to studying “the wrong way.”

Suddenly the security of knowing the “way things work” is gone, and the agonizing new question becomes, “How could I not have seen this before?”

At a point like this, the most mature option available is to concede your opinion to the new information, just as Gore conceded to President-elect Bush earlier tonight as we write these words, after the US Supreme Court slammed the door shut on any additional vote recounting. Then, as more than 50% of voting Americans had to do, take a deep breath, work through the shock and anger and move on with life, allowing the obvious new truth to be incorporated into the collective base of human knowledge.

It is the only way for science, or in this recent example, government, to progress forward. And even though this conciliation may be the most mature choice, it is certainly not the most popular choice. No Supreme Court will ever force scientists to concede their own beliefs; and in the case of the 2000 US presidential election, had the Supreme Court not acted, it is very likely that Gore would have kept on fighting.

So in the case of science, we must remember that there is no oversight, no “higher body” of leadership that will force a new and unpopular scientific model to be adopted. Ultimately, such a scientific revolution can only come about from the will of the public, but the public cannot express a will about something that it doesn't even know, due to official media suppression of the information.

Thus, many people go on blindly trusting the beliefs of the mainstream scientific fraternity, while being almost completely unaware of the problems, paradoxes and anomalies that have riddled many of these models, or of the remarkable alternative ideas that are being discussed.

Money is another very key issue that must be addressed, since it is easy for the common person to forget about its importance in science. A university education can command a very high salary, providing that the grants are made available for research. For a scientist to concede that his entire model is incorrect or at least seriously flawed, it is very probable that his entire "comfort zone" and source of living would evaporate, and he would be out looking for a job with then-irrelevant technical knowledge.

What good is a highly educated specialist in a field that has suddenly been upended? This is the state that we now find ourselves in, and it is also the main reason why we cannot expect that the new paradigms being featured in this book will be appearing on newspaper headlines anytime soon. Simply put, scientific change has historically come in small bits and pieces, as the large-scale paradigm shifts are too overwhelming for the majority to allow them to squeeze through.

However, this time of the Shift of the Ages, prophesied for thousands of years, is all about critical mass - a time when the new information just becomes too overwhelmingly strong to be put down, and the Truth bursts through all obstacles to become the King of the Mountain once more. Checkmate.

Though approaching with ever-increasing swiftness, this moment has not yet fully arrived. To many of us, our current situation does not appear to be much different than it was at the time of Nicholas Copernicus, who made the simple and yet utterly revolutionary discovery that the Sun was at the center of the Solar System.

Although the Copernican model was a much simpler and more logical explanation for the astrophysical observations that had been made at the time, he suffered bitterly at the hands of the religious / scientific establishment, who spared no expense in destroying him.

Even now, the scientific discoveries that contradict the Establishment perspective are ignored at best, often met with scathing criticism, scorn and derision, and at worst can lead to the harassment, financial and career ruin or possible assassination of their creators. The degree of mainstream university credentials that such researchers possess -- including Ph.D.'s from the most prestigious institutions -- is totally ignored in the rush to subvert, ridicule, threaten or even kill them.

As one example, this author met personally with a frontier researcher in harmonic physics who lived alone and came home on two different occasions to a burnt match placed exactly in the center of the carpet in his computer room; a warning of what would come if he said or did "too much." And as this researcher indicated, popularity and public exposure is the most adequate protection against assassination, since those conducting the harassment do not want to attract attention.

Hence, we are by no means living in a society that condones innovation and advances on the mass scale, except where it is convenient for those individuals and interests that are already in power. And as this book progresses we will see that the byproducts of this new model of the universe include technologies that can literally save the earth.

Within the new model, every reader will be able to grasp the convenient reality of anti-gravity propulsion and a limitless source of "free energy" that renders all other forms obsolete, whether petroleum, coal, nuclear, solar, wind, hydrostatic or otherwise. Readers inclined to be inventors in these areas will now have the conceptual framework from which to build their experiments.



## 1.4 A SCIENCE OF LIFE

Furthermore, this new model also heals the split between science and religion that has existed in our society since the Renaissance and Enlightenment periods of the 1600's and beyond. Up until this time, Western civilization simply relied on faith in the Bible to answer the questions of the Universe. When the Renaissance came along, science seemed to be the saving grace, the Holy Grail that would bring humanity out of the Dark Ages and into Light. And yet, what we have seen is that:

**Science is very good at studying and explaining death - but very poor at studying and explaining life.**

The term "Creationist" is a rather scornful label that is used to describe a researcher who still wants to adhere to Christian Biblical teachings about an Ultimate Being having created the Universe. As part of the scientific revolution's opposition to religion, the entire idea of an Ultimate Being has been cast aside in favor of philosopher Laplace's purely mechanical model of the Universe known as "logical positivism."

So, we might say that death is understood very well, but creation and life are not. The "scientific" conclusions of "positivism" for the creation of our Universe and of human life border on the ridiculous: the Universe supposedly came from an explosion of "nothing" and humanity supposedly came from an amino acid "soup" that was created when simple elements in water got struck by lightning. That is about as far as "positivist" science ever goes in explaining how the Universe and ourselves were created.

Neither of these explanations hold up under scientific scrutiny. We will explore later how many flaws there are in the Big Bang model. As for human DNA, its own co-discoverer Crick later calculated that the molecule is infinitely more complex than could ever have occurred via random evolution in the necessary allotted time. And despite these flaws that yearn for a new explanation, we continue to see a Universe with an impossible, explosive beginning and a slow and inevitable death.

These same beliefs carry through to how we think about ourselves. Despite our beauty and majesty, the prevailing scientific dogma allows us to conclude that we are simply the dying end-products of a giant explosion of "nothing" followed by another explosion of "soup." Once our death is complete, we sink back into the black abyss of Primordial Nothingness. With one wave of the "magic wand," all the paradoxes and mysteries of life in the Universe are excused away.

We are far more than soup. In this new model, the true glory and power of the human being is revealed - and we will see for the first time how fundamentally interconnected with the Cosmos we truly are on every level.

So, based on the information that is now available, we can conclude that we are good at seeing and believing in life within ourselves and in the plants, animals and bacteria, but we are very poor at seeing and believing in life within anything else, whether the Sun, the planets, the stars and galaxies, or simply Space and Time itself. We have made the quite natural mistake of judging life by the immediate standards that we have established by observing things that eat, excrete, breathe, grow, move around and reproduce.

By about fifth grade, each of us will have been told that if something doesn't "do" these six things, it is not alive; and if we answer the test questions in any other way than this, we are "wrong" and will be given the label of "failure." And yet, the words of alleged ET group Ra and other sources continually tell us that the entire Cosmos is One Living Being, and that life holographically exists within every part of the whole.

That means that even rocks and minerals have their own primitive form of consciousness, since they are a part of that same One that we are a part of. When we see that every "atom" in the Universe is drawing from an unseen energy source and radiating energy back into that source as well, then suddenly our definitions of "life" can be far more flexible.

Much of this "new" information is simply a return to ancient teachings, and more and more it is re-entering into the minds and hearts of spiritual seekers everywhere. In spite of this, the vast majority of us simply do not have the time and insight to collect all the pieces of the puzzle, especially in the more technical aspects.

The often-maligned areas of consciousness related to the intuitive and psychic abilities are given clear, easily understandable definitions in this new model. And even though mainstream parapsychologists have endlessly demonstrated the reality of the human psychic ability with levels of rigorous statistical accuracy that are far greater than necessary for a court of law, the mainstream simply has rejected these ideas on the grounds that "extraordinary claims require extraordinary evidence." We now have that evidence.

## **1.5 DISCLOSURE IS IMMINENT, RESOLUTION MAY NOT BE**

This book also directly addresses the concept of extraterrestrial beings that are now visiting our planet at this time, by providing a model for abundant living energy all throughout the universe that produces sentient existence on various planes or dimensional levels.

At the time of this writing, Dr. Steven Greer, a prominent emergency-room physician and the head of the CSETI organization, has funded and launched The Disclosure Project, will culminate in a mass public disclosure of UFO information. This material has been culled from 500 or more top-secret witnesses with access to solid, factual information regarding the UFO Cover-Up.

At the time of this writing, the beginning of an ongoing series of presentations is about to be held on May 9, 2001. It is important to realize that Dr. Greer has briefed members of Congress, the President of the United States, the acting head of the CIA, the United Nations and other world leaders about this presentation, and they have universally given him the green light to proceed. To those who have not heard about this before, it might at first seem to be a joke, but the information is freely available for all to survey at [SETI](#) and [Disclosure Project](#).

Hence, it appears that the legitimate, elected global body politic has chosen Dr. Greer as the man to disclose the reality of extraterrestrial life to the Earth. On May 9, nearly two dozen first-hand witnesses of the absolute highest caliber will have come forward to take the stage in a major press conference, revealing to the world all that they know for the first time. All Senators, Congressmen and news media were invited to attend this event at the National Press Club in Washington, DC.

This action will hopefully give members of Congress and others the catalyst that they need to mount an official investigation without fear of blackmail or assassination, in order to gain leverage to allow them to acknowledge the truth publicly.

This “disclosure ” information will include the fact that ever since the mid-to-late 1940’s, human civilization has been in possession of crashed or “gifted ” extraterrestrial hardware that utilizes certain aspects of exotic physics systems to function. Such a disclosure may well be tantamount to the moment of “critical mass ” that we mentioned above, where the truth can no longer be restrained from the public any longer, and very sweeping paradigm changes will have to be made very quickly.

It is for this reason that government informants have indicated their belief that the two camps who will be most adversely affected by this disclosure will be religious fundamentalists and scientists. In both cases, there is an entire life of set belief patterns that could be upended in a heartbeat - and most people don’t enjoy those moments very much.

So what happens when you suddenly realize that a significant amount of your favorite “toys ” were not invented by humans? According to government whistleblowers such as Colonel Phillip Corso in the book *The Day After Roswell*, a great deal of our modern technology, including integrated circuits or “computer chips, ” transistors, fiber-optic cables, lasers, infrared night vision, Teflon, Kevlar, light-emitting diodes or LEDs and much more have all come from our celestial endowment.

Wilcock had received identical information from a friend who spoke directly to an ex-NASA physicist in 1993, four years before Corso’s book was published, and directly reconfirmed it three years later in 1996 with an aerospace informant at a UFO conference. This is certainly a very humbling fact to be confronted with, providing that all along you have simply trusted that our technology is the fruit of basic human ingenuity, hard work and the ongoing path of scientific progress.

Even once this initial disclosure is made, it is very likely that media suppression will reign and even those who have seen or heard it will refuse to believe it, and will conclude that it is simply a gigantic, orchestrated fraud perpetuated on the American people. Unfortunately it will be surprising if the event is covered at all in mainstream American media sources. And even if it does “work, ” such things as actual extraterrestrial bodies or hardware may not be as forthcoming from the “powers that be ” as we would have liked them to be, thus extending the impasse.

As this book comes to completion, some in the UFO community are speculating that either by accident or by design, the US Presidential election impasse of November and December 2000 was a “practice run ” for the much-longer delay that will result after an initial disclosure takes place and we then have an extended waiting period before a comprehensive, multimedia government statement of “The Truth ” will be made available to the public.

Each day that passes while the government refuses to “come clean, ” while promising that all will be told, would only increase public agony and stock market turbulence - especially with the announcement that technologies exist that will replace the entire fossil fuel economy once implemented.

The reader of this book will not be presented with a great deal of “typical ” UFO education, as these materials are now widely available due to what many researchers identify as a government and media-run program that is acclimating the public for this eventual disclosure.

For information about this program and much more, we highly recommend reading all articles on Dr. Greer’s CSETI website, The Disclosure Project website and Dr. Richard Boylan’s website at [www.drboylan.com](http://www.drboylan.com), beginning with the disclosures of Dr. Michael Wolf in linear order. Dr. Wolf (who died prematurely in the year 2000) was allegedly a very high-level member of an elite committee that was originally known as MJ-12, which dealt with the UFO reality.

According to both Dr. Wolf and Dr. Greer, the biggest political concern that is being weighed out is whether the oil-based fortunes of the world's elite will crumble as a result of ET technology rendering fossil fuels obsolete. In order for them to be effective in maintaining control, any disclosure must reduce this damage as much as possible.

## **1.6 FEAR IS NOT A JOKE**

There is another factor that must be considered, which most people who have actively studied the UFO/metaphysics field can quickly forget about. No matter how many Steven Spielberg movies are made to acclimate the public to the reality of benevolent, loving extraterrestrial life, there are still going to be those of us who will have a negative reaction.

Movies such as the "Alien" series, "The Thing," "War of the Worlds," "Independence Day," the television series "V" and many, many more have presented extraterrestrials as being the ultimate horror in the universe - a sly, deceptive, malevolent, demonic force that is straining at the gate to infiltrate our planet and either colonize, subdue or just plain eat us in a giant cosmic barbecue party.

In the past, when people talked about the "evil aliens" idea it was simply something to be laughed about - but it won't be funny any more once the disclosure has been made and people's own innate prejudices suddenly take hold.

The fact is, if you live your life expecting that bad things will happen, then they will. The mainstream science of psychology calls this a "self-fulfilling prophecy." Fortunately, in this case there is no real danger, only the consequences on physical health that fear can produce. Very reliable sources continue to emphasize that the primary role of the Visitors is to protect us. Indeed, since we are informed that one of their main purposes is to repair our damaged planet and prevent full-scale nuclear war, we would be in far more trouble if they left us.

Simply put, the evidence for extraterrestrial visitations of humanity dates back thousands of years. And this knowledge is indeed becoming mainstream, as a recent Internet expose from ABC News Nightline clearly laid out these data points on a surprisingly well-done timeline. As little as ten years ago, such a mainstream disclosure of information would have been unthinkable.

These timelines clearly show that in the majority of historical epochs, the visitors were heralded as godlike beings. There is ample evidence that they did indeed interact directly with humanity, although this evidence is now seen as simply mythological. These interactions were very beneficial; in the case of Sumer, for example, a highly advanced civilization was born from a nomadic hunter-gatherer culture in a remarkably short period of time.

The military mentality, however, is constantly searching for the next evil menace, with intent to destroy it. Not surprisingly, numerous informants have revealed to Dr. Greer and others that right now, totally outside of international oversight of any kind, there are rogue elements within our military and governments that are actively shooting down extraterrestrial spacecraft with advanced "Star Wars" satellite technology whenever they get the chance.

Some of the informants have stated that this is happening on an almost daily basis! And in case you think that there is no documentation to support this, the film from Space Shuttle mission STS-49, widely circulated on the Internet and certain documentaries, clearly shows a series of round whitish objects flying over the Earth and performing supposedly impossible flight maneuvers, followed by what obviously looks like a land-based beam weapon shooting up at one of them.

When the beam is released, a burst of ionizing radiation brightly lights up a large portion of the Earth's atmosphere for a brief flash - something that would probably be seen by most as lightning, if it was even noticed at all. In that particular case, the object was unharmed, zipping away from the danger with seemingly impossible speed and dexterity.

So if you are one of those people who choose only to have a fearful reaction, then you should be aware that certain rogue elements within government, corporations and military are automatically assaulting anyone who tries to visit us, for any reason.

With the abundant evidence that these same entities have aided humanity all throughout the ages, including the Hindus, Sumerians, Egyptians, Greeks, Mesoamerican and Oriental cultures, it is quite premature for these rogue quasi-governmental elements to "shoot first and ask questions later. "

And yet, despite these openly hostile acts from Earth people, there continues to be no attack from the visitors, nor will there be in the future. Simply put, these are beings that have watched us for millennia, are aware that we desperately need help and are offering that help, regardless of the risks involved - and they will continue to do so as our global situation gets more and more desperate and seemingly insoluble.

Based on all this information, which is increasingly being dropped right into the public's lap, we now feel confident in saying that those who refuse to see the truth of the "big picture " of extraterrestrial interactions with humanity are simply exercising their free-will choice to deny the overpowering amount of solid information that exists.

Providing that Dr. Greer's project and other disclosure efforts go forward as planned, then in the near future that choice of denial will no longer exist as an option.

[11/29/07: As most of us know, the conference did occur, and the videos are available on YouTube and elsewhere. However, 9/11 eclipsed any momentum that had been created, and we are still in a situation where 'disclosure' is only hypothetical.

The point is that for those who want the truth, it is easy to find. Our colleagues at [ProjectCamelot.org](http://ProjectCamelot.org) have amassed an impressive video library of witness testimony you can watch online.]

## **1.7 EXTRATERRESTRIALS, EVOLUTION AND THE VALIDITY OF PSYCHIC INFORMATION**

And so, if the reality of the presence of extraterrestrial intelligence in our lives is no longer ignored, all of society will have changed on a very fundamental level; the genie will have been freed from the bottle. It would be quite humbling to realize that we are not the pinnacle of evolution in the universe.

Then, the question of how we could become like these beings will have to be asked more seriously. Are they truly millions of years ahead of us in their technological, physical and spiritual development, as many often believe?

Trapped within layers of sedimentary rocks, our geological history shows repeated cases of "punctuated equilibrium, " where the life on Earth suddenly and spontaneously evolves into something new - something higher.

And indeed, many credible sources suggest that the ETs are well aware that this most important and surprising event in human history - *The Time of Global Shift* - is very soon to occur here on Earth. And thus, there is a very good

reason for all the acceleration in technology and planetary chaos that we have seen, especially in the last century; humanity is changing on a very fundamental level.

With the proper scientific framework in place, we can understand why so many different sources of information have predicted this event with such total confidence - including the crown jewel of Western Christian prophecy that came through the words of Jesus, who heralded the arrival of a "New Heaven and New Earth " that occurred along with a "second coming of the Christ Spirit. "

Many believe that our celestial brothers and sisters are here to guide us through this time of transition, to be available to help us quickly return our world to its natural, pristine state with hyper-advanced technology. Many sources do suggest, though, that these entities must obey their own version of the Prime Directive, featured in the Star Trek television series.

The "Prime Directive " idea suggests that the Visitors cannot interfere with our affairs until we specifically and globally request their assistance. Obviously, that moment has not yet arrived.

And so, beginning in modern times with teachers such as Nostradamus, Blavatsky, Gurdjeff, Ouspensky, Rudolf Steiner and Christian Sunday school teacher Edgar Cayce, we now have documented proof that telepathic contact with such Higher Intelligences can be rendered with precision.

The fruits of such contacts include volumes and volumes of information that are arguably composed directly from the minds of these extraterrestrial forces, using the human being only as a conduit or channel through which the information may be produced.

In the finest cases, repeated accurate prophecies of future events are given as well as many other methods of proof that lend irrefutable legitimacy to these sources. As Cayce biographer Sidney Kirkpatrick discovered for himself, the proof of Cayce's psychic ability is far more redundant than necessary for a court of law.

For example, with no further "front-loaded " information than the name and address of a given person, Edgar Cayce could go into an unconscious trance state and give that person a completely accurate medical diagnosis and treatment plan, providing that they stayed at the given address during the time that the reading was to occur.

And if you believe this ability was merely an occasional, coincidental "fluke, " you must remember that over fourteen thousand of his psychic readings that demonstrate this ability are available to the public on CD-ROM. Cayce's organization, the A.R.E., is still actively promoting "The Work " worldwide, fifty-six years after his death.

Again, from sources such as Cayce, we can indeed discover all the clues to unravel this mysterious new model of the Universe, and explain the numerous anomalies of science that are becoming increasingly well known each day. A good deal of information regarding these "psychic " connections is offered in our first volume, *The Shift of the Ages*.

However, there is a significant problem that must be immediately addressed. Since the era of Edgar Cayce ended in the mid-1940's and especially with the rise in popularity of the Internet, anyone can assert themselves as a "channeler " and begin publishing readings in books or online, which are often phrased in informal, conversational language and do not have any real means of proof or validation.

(Cayce's readings were very technical in their phrasing and by no means easy to understand, in a similar sense as the "quatrains " of Nostradamus have a bizarre, cryptic quality to them.)

It is well known that most modern channelers wildly contradict each other on many key subjects, and then if one person's work gains enough notice, others can then "channel" the same distorted information, such as failed future prophecies of disaster. Some of these channelers have become very popular, with international organizations, high profits and extensive outreach.

Furthermore, a good number of those who follow these "channelers" will become highly aggravated, saddened or offended when their favorite figure's work is actively held under scrutiny, and thus they remain unaware of the majority's opinions on the subject.

As a result of this widespread abuse, which has actually become the norm to a significant extent, the field of channeling has suffered a near-total lack of credibility in much of the modern Internet community, even among those open to metaphysical ideas. In truth, this is unfortunate, as there still remain those sources whose integrity is uncontested.

Based on the above caveat, any use of psychic information in this book may seem at first to be a fatal mistake, as ultimately this book is an exercise in frontier scientific exploration, not groundless esoteric speculation. Therefore, we want to make the point very clearly that every argument from the "revealed teachings" that we will use in this book, with only a few number of exceptions, has now been experimentally verified, however unpopularly, as a scientific fact.

This means that we do not need to have "faith" in the words of the teachings themselves, as we can find the necessary information through solid scientific investigation - the words simply help us understand what we have already discovered and give us a much-needed "outside" perspective. One exception to the rule will be from readings produced by Jane Roberts that provide vivid insight to the scientific concepts that will have been discussed up until that point.

## **1.8 REMOTE VIEWING**

Although many "channelers" can produce a host of distorted and contradictory information, the science of remote viewing has made significant strides in standardizing a procedure not unlike that conducted by Edgar Cayce many years before. This science was originally devised by the military in the 1970's through cooperation with renowned psychic and Scientologist Ingo Swann, and its purpose was to obtain data about locations that could not be physically seen or studied.

The most important aspect of this process is to train the person to completely override and shut down the influence of the conscious mind to allow information from the higher mind to come through.

In the more advanced levels of remote viewing, the person actually has an out-of-body experience where they directly perceive themselves at the target site, can move around at will and describe what they are seeing. This is quite similar to Cayce's ability to go and visit the body of the person receiving a "reading" and give it a medical diagnosis.

Joseph Mc Moneagle is the original, probably most solid and well-known remote viewer, and in his books there are many pictures of targets that he had been assigned that are compared with sketches that he produced in trance. Many of his remote viewing diagrams are no worse than anyone would make from simply sketching a photograph from the conscious state. His results were this accurate even though he had no idea what he was viewing; and the protocols for how this unseen data is collected are exacting.

In the case of a psychic like Edgar Cayce, the unconscious state provided an opportunity for an even higher level of depth than can be gained by remote viewing. The function of the conscious mind was literally shut down altogether, and only the higher mind would speak as it traveled to each client's body, diagnosed its ailments and tapped into what it called the "Akashic Record" to find the best treatment.

When a person tries to "channel" from the conscious state without training in the necessary protocols, they are very likely to have the conscious mind distort their information. This author has devised his own set of protocols, based on remote viewing logic, that can eventually lead to very accurate messages from Higher Intelligence if properly and regularly practiced. On our website, there are hundreds of cases of documented prophetic accuracy using this technique.

The ongoing success of this process is part of what has made this book possible; the research has been guided every step of the way, and thus this book is truly a group effort. Mr. Wilcock cannot claim to be the original discoverer of the findings in this book, even though they have never been published before. Every point has been checked and rechecked for accuracy through Higher Intelligence by the use of these visionary techniques.

In addition, this book could not have been written without our use of this technology for funding, by performing "dream readings" for a variety of clients. We ran the business between 1998 and 2005, and during that time we had at least a 97-percent satisfaction rate. There were many reports of dramatic accuracy and truly life-changing guidance and insight.

In the dream reading system, Wilcock slept for each client with the intention to dream for them, and later awoke with the data. That data is dictated onto a recording device and then a trance state is induced to allow the Higher Self to speak. The dream protocol allowed the influence of the conscious mind to be completely subverted, and with the proper knowledge and understanding of the symbolism used by the subconscious mind, the client's message is easily seen.

One of our best examples of psychic accuracy was when we had a dream for a client where a man was having trouble setting up a tripod. When the trance reading began, the first words after the greeting were, "The tripod represents..." et cetera. When the client received the cassette in the mailbox, he had just awakened from a dream where he had trouble setting up a tripod, and Wilcock had not told him anything about the results before this.

Outside of our own readings, this author's dreams have been the single most valuable resource in helping to illustrate how the different data points in this book fit together. In this way, we follow in the tradition of many other pioneers who have used this interface between the symbolic language of the Higher Mind and the literal language of the conscious mind to make advances. These pioneers include the Wright Brothers, Thomas Edison, Albert Einstein, the discoverers of the DNA and benzene molecules, and many more.

## **1.9 THE LAW OF ONE**

As we have already indicated in *The Shift of the Ages*, there is one additional set of "channeled" materials that deserves to be showcased alongside Cayce and all the best material in history. A series of five books known as the *Law of One* series catalog over 150 question and answer sessions between Don Elkins, Ph.D., a university physics professor, airline pilot and UFOlogist, and an extraterrestrial group that identified itself as "Ra."



In the opinion of our colleague Dr. Scott Mandelker, a Ph.D. in East-West psychology, popular media figure and expert on world religious teachings, “the Ra Material is the single most important source of written teaching that I have ever encountered.”

The human players in the Ra contact were Dr. Elkins, Carla Rueckert and Jim Mc Carty. Rueckert had worked for over 20 years to perfect the art of channeling, complete with a wealth of verifiably accurate data that she could not have known consciously. When Mc Carty joined the group, ostensibly to help Rueckert and Elkins catalog their extensive amount of information, a sudden and unexpected change occurred.

For the first time in her life, Rueckert lapsed into a completely unconscious trance state during a group meditation and began speaking for Ra, having no memory of what she said upon awakening. Again, the number of cases where genuine unconscious trances have truly happened are quite rare, and this contact had the advantage of completely removing Carla’s conscious mind from the process, thus stopping any of the data from being distorted.

Almost immediately there was a noticeable difference for Dr. Elkins between the words of Ra and anything else that had ever been produced through Carla before. Ra explained that the harmony and fidelity of the group was strong enough that they were able to secure what they called a “narrow-band connection,” which required an extremely sensitive and exacting set of protocols to properly conduct.

Indeed, the demands that these sessions placed on Carla were quite intense, as her body essentially had to remain completely motionless and unconscious for over an hour at a time. But in the midst of this state, the words that came through Carla’s mouth were clearly not those of Carla.

The material that is presented is of such depth and complexity that a minimum of one or two years is required to properly study and assimilate the information in all five books, and Ra’s words often made Dr. Elkins’ scientific and spiritual knowledge seem ridiculously inadequate. And yet, Dr. Mandelker’s studies have proven that the words of Ra have demonstrated a very high understanding of the deepest revelations of world religious philosophy, especially Eastern schools of thought such as Taoism, Hinduism and Buddhism.

Mr. Wilcock began his daily study of the Law of One series in 1996, and by 1998 he had understood enough of the material to begin writing about it in his own words and comparing it with other data. As he scanned the Internet and bookstores alike, he realized that no author had integrated Ra’s concepts into a tangible model of the Universe, presented with scientific evidence.

Well over 300 books had been written on Edgar Cayce -- one estimate is over 670 titles -- but only three books mentioned the Law of One series directly: *UFOs and the Alien Presence* by Michael Lindemann, *Alien Identities* by Dr. Richard Thompson and *From Elsewhere* by Dr. Scott Mandelker.

Therefore, within the five Law of One books there lay an untapped gold mine just waiting for someone to come along and harvest; for among many other valuable insights, during the course of Ra’s interaction with the group, an entirely new, self-consistent universal cosmology of Oneness was being developed.

And more importantly, Ra’s words were not at all in the category of speculation; they made many very definitive points that could either be right or wrong, but there was no middle ground. They made exacting statements about the length and nature of certain structures of time, of the importance of sacred geometry in understanding the architecture of the Universe, of the quality and number of dimensions in the Universe and of the dynamic nature of an energetic system that tied everything together into one grand model.

Granted, many of Ra's conceptions would remain in the area of speculative metaphysics, but many others were quite plain. And Wilcock realized that since the group's data had been gathered in 1981-83, a wealth of scientific information had been produced that shed new light on the validity of Ra's statements. For now, we will limit this to eight examples that help to give a broad portrait of the various areas that this touches upon:

The aether models were certainly not popular in 1981 and the term "zero-point energy" had not yet been coined, and yet Ra indicated that all of the Universe was composed of vibrating "intelligent energy" that it called "light-love." Now we have all the needed research to back this up.

Ra indicated in 1981 that as we got closer to the time period of 2011-2013, we would see a greater and greater heating of the Earth's core due to humanity's resistance to an instreaming higher energy, and this would in turn create an accelerating number of Earth Changes, which they called 'inconveniences.'

Years later we were slammed by the El Nino / La Nina weather effects, which are caused by a significant heating of the oceans. The only model that properly explains this is the idea that the inside of the Earth is getting hotter, thus heating the oceans from underneath much as a burner heats a pot of water on a stove top.

From the data at [www.michaelmandeville.com](http://www.michaelmandeville.com), we also now know that there has been an overall 400-percent increase in earthquakes above 2.5 on the Richter scale since 1973, and a roughly 500-percent increase in worldwide volcano activity since 1975. And at [www.tmgnow.com](http://www.tmgnow.com), Russian scientist Dr. Alexey Dmitriev reveals that between 1963 and 1993, there has been an overall 410-percent increase in worldwide natural catastrophes of all different categories combined.

Ra indicated that the entire Universe is structured like a giant galaxy, which at the time could not have been supported with the available scientific data. However, we are now able to present three different areas of solid evidence that make a very strong suggestion that this is indeed the large-scale structure of the Universe. Even mainstream news articles reported in 2000 that Cosmic Microwave Background radiation measurements had determined that the visible universe was actually "flat."

Ra indicated that the Universe has eight "true" planes of existence, which most would call "dimensions," organized by vibration into an Octave that is similar to the octave of sound or the rainbow spectrum of colored light, with geometry playing a crucial role as well. We now have compelling mathematical and physical evidence that all of this is so.

The most cutting-edge physics theories of today have said that "it's as though there is some deep numerology [of the number 8 in the modern "Superstring" hyper-dimensional models] that no one understands."

Ra indicated that the Galaxy was divided up into a "three-dimensional spiral" of differing areas of energy vibration, and that as our Solar System drifted from one area to another the density of the energy around us would change, culminating in 2010-2013.

In the work of Dr. Alexey M. Dmitriev and others, we now have physical observations from all across the Solar System that suggest that we are moving into an area of higher energetics in the galaxy; and all signs indicate that these effects are continually increasing. Mr. Wilcock's personal research now makes a strong suggestion that the Galaxy is harmonically divided into exactly 8,640 "secondary" energetic regions, each of which are traversed by our Solar System in exactly 25,920 years.

Ra discussed the importance of "25,000-year cycles" of time, and the fact that three of these cycles were required for an even larger cycle to be complete. Although the importance of the 25,920-year cycle of time is well known in the

metaphysical community, connected to a long-term wobble in the Earth's axis known as "precession," no one had any reason to think that three should be seen together.

And yet, Maurice Cotterell's discoveries of long-term sunspot cycles, first published in 1989, can ultimately be used to demonstrate that for all cycles in the Sun to synchronize properly with each other, three 25,920-year periods are required. This also fits well with Mr. Wilcock's discoveries, which suggest that there are exactly 2,880 "primary" energetic regions in the galaxy.

Ra was very specific about the idea that the instreaming energy of higher dimensions formed an interconnecting network of straight lines of energy force over the Earth. They indicated that at certain areas where the lines crossed, many anomalous effects would be found. Since that time a wealth of data has emerged to verify the existence of gravity as an instreaming energy, as well as the reality of the "Global Grid" and its tremendous effects on physical matter and conscious life.

Indeed, we have found the lines, and where they cross we see the exact effects that Ra had indicated. And, with the work of Richard Pasichnyk, we can see these energetic effects at work throughout the entire Solar System.

Ra indicated that the Great Pyramid was structurally designed to harness this "upward spiraling light energy" from the Earth's grid. In our last book *The Shift of the Ages*, once we discovered the true multidimensional importance of "sacred" geometry, we could understand how the pyramid was able to create various effects such as a raising of the vibrational speed of Earth's electromagnetic field and a decrease of the field strength of gravity within it.

These Pyramid effects on energy were discovered by Gregg Braden and are now occurring all over the Earth, indicating that we are in a "collective initiation chamber," which is precisely what Ra taught.

So, as we move right through to the present, it appears that every month there are new scientific findings that further validate and verify Ra's accuracy. As a result of these obvious connections, we can conclude with confidence that Ra is a genuine extraterrestrial intelligence and that their words are of clear value to us.

Our purpose in this book is to present a complete, unified cosmology that is very heavily inspired from Ra's teachings, in the hope of bringing each reader much closer to an understanding of how the Universe truly functions, and of their own nature and role within it. After reading this book, it should be much easier for the reader to approach a demystified study of the Law of One series, as many of Ra's key points will now have the appropriate context for discussion.

## **1.10 CYCLES OF TIME**

When we consult Ra and other reputable sources of ET information and compare them to "frontier" scientific discoveries, we come to a unified spiritual and scientific cosmology that essentially remains constant. Discoveries in science that are just now coming into view are given a perspective that frames them as part of an orchestrated, multidimensional, conscious Universe that is in a constant state of evolution.

With this model is the understanding that God, or the Oneness, always operates in cycles - a fundamental truth that our colleague Dr. Scott Mandelker refers to as the "Cosmic Plan." Just as there is a cycle to a human lifetime, with birth, maturation, adulthood, aging and death, so is there a much-larger curriculum by which each of us, as a spark of

the One, must fully return to that Oneness yet again, through successive physical incarnations in a variety of dimensional or energetic “density ” levels.

Obviously, our minds in the “third dimension ” do not appear to be a true manifestation of Omniscience for most, in the sense of having total, instantaneous union with the consciousness of all entities in the Creation and living in that state of awareness constantly. In the model espoused by Ra, other sources and almost all world religions, our eventual destiny is to return to that point of Omniscience, and this occurs through a set growth curriculum, so that there are clear stages of progress to be made along the way.

All of these teachings tell us that the true nature of the “dimensions ” in the Universe is that each one of them is a plane of existence where all life is increasingly Unified with what we could call God Consciousness, or Oneness. We will make a case for the reality of these planes, in terms of consciousness, in Chapter Two, with later data in additional chapters throughout the book that supports the notion from a physics perspective.

The evolutionary process through these various planes does not occur in random intervals of time, but rather goes through a cyclical structure, as described above. Again, what we have is a three-dimensional “standing wave ” of invisible energy (which some scientists are now referring to as “dark matter ” and “dark energy ”) in the galaxy that is divided into precise mathematical increments of frequency, and that essentially remains stable and motionless as the stars and planets move through it.

Though this “aether ” energy is not visually detectable, we will present a wealth of experimental data that verifies its existence. So, in a simpler form, the Ra hypothesis is that the natural passage of a planetary system through the galaxy is also a passage through discretely different areas of energy.

These changing energy levels are what allow the inhabitants of each planet to move forward en masse - a form of gradation on the soul level. And this gradation provides a valid reason for why so many are seeking “spiritual growth ” on our planet at this time - we now can have an idea of exactly what we are “growing ” towards, and why there is such an incredible feeling of urgency.

### **1.11 THE PROMISE**

Perhaps the most perfect articulation of what the human being could become as a result of this natural energetic transition can be found, incidentally, in straight-ahead Christian prophecy. One of the most favorite Bible quotes in the Edgar Cayce Readings was John 14:12, where Jesus said, *“As I do these things, so shall ye do them, and greater things. ”*

The Cayce readings indicated that Jesus defined the pattern that all others were to follow - to overcome the desires of the Ego self and attain true spiritual awakening in order that “Not my will, O Father, but Thy will be done. ”

If we study the Dolores Cannon book *Jesus and the Essenes*, we learn that the original intention was not for us to see that Jesus’ physical body had rejuvenated. Instead, we were supposed to understand that his body had transformed into Light, and later reappeared in a newer, more energetic form. It is for this very reason that Jesus did not look the same to Mary and the others when he returned, in terms of facial appearance; but nevertheless, he was able to manifest the same wounds in his energy body in order to prove to them that it was really him.

The evidence on the Shroud of Turin clearly shows that somehow, a three-dimensional holographic image of the body inside was burned into the fabric, and this could only have been accomplished at extremely high temperatures occurring all over the body simultaneously.

Therefore, the controversial evidence of the Shroud supports the idea that Jesus had completely dematerialized his body in a tremendous burst of energy. (This may or may not represent what will happen to the average person as this point of transition arrives.)

Biblical prophecy also tells us that there will be a "Second Coming of Christ," and many Christians are convinced that this simply means that one day Jesus will return to the Earth and usher in a New Kingdom of "a thousand years of peace."

More to the point, we must remember that it was called the second coming of Christ, not the second coming of Jesus. The Cayce readings explain that the Second Coming of Christ was intended to mean that the same Christ Spirit that came alive in Jesus would now be awakening within all of humanity, some more quickly than others.

What we may not be aware of is the prophecy [John 14:12] that all the abilities that Jesus demonstrated in his three-year ministry would eventually become our own abilities; and that we would have "even greater" abilities than what Jesus had demonstrated. Now imagine a whole planet of people who think, talk and act in this manner, with the same compassion and spiritual ability, and you will understand what this "New Heaven and New Earth" is truly supposed to be.

In the words of Ra, the new vibrations that will surround the earth will make life "one hundred times more harmonious" than what we have now.

While these concepts may seem highly esoteric and not even remotely possible in our "real world," the fact is that humanity in general has long stood in ignorance of its own true powers - and by default, it has denied the true mysteries and powers of the Oneness as well.

Once the concepts of this new worldview in this book have been carefully laid out, you may well choose not to believe any of it, and that is fine. If you find yourself unable to accept the idea that something this fantastic could really happen on Planet Earth, we would invite you to seek within for whatever sense of limitation you might still be feeling. Has God left you behind to carve out an existence on this lonely, commerce-driven planet?

Do you know exactly how the "real world" is and will always be, and feel abandoned to live your life by that pre-set plan, playing the "human game?" Is God simply too absent from the world, too distant and detached from anything "real," to have ever concocted such a wonderful surprise as this for humanity? Will you simply refuse to allow it to be true in your mind because you don't believe that something this grandiose could ever really happen in your life?

Think about this upcoming event as similar to a first love, where you never could believe that the one you cared about so dearly really did have the same romantic, loving feelings for you.

When you finally realized the truth and had your first kiss, the world became a very different place; everything seemed to glow, and for the first time you noticed the richness of a touch, the subtlety of the wind rustling through the trees, the majesty of bright, bold colors, the glorious tastes of a cornucopia of delicious food, the joy of your favorite music, the wonderful smells of springtime and the renewing warmth of the Sun.

Up until that moment, you had shut off your senses to the songs of the birds, the feeling of the grass in between your toes, the smooth rush of ocean waves lapping against the shore, the moist, earthy smell of the forest after a fresh rainfall.

As you stared into your lover's eyes, there was truth in that moment; life was good, and what had seemed so impossible just a few seconds earlier was suddenly a breathtaking new reality. No matter how you may have imagined that it would be, you couldn't experience those emotions until the moment had actually arrived. And you are the winner, in every sense of the word!

Hence, if we would choose to reduce or compartmentalize the abilities, powers and glories of the One, then we have already imposed constrictions and definitions on the power of Infinite Mind and Limitless Love. Our own beliefs and attitudes of scarcity and restriction must be abandoned in the joy and glory of the true Plan of the Creation, revealed throughout time by prophets, mystics and healers and only now verified through science.

## **1.12 ORIENTATION**

Since the amount of information in this book is quite sizeable and organized, we have used this introduction to give a preliminary idea of its basic contents. It is our hope that through such a summary as this, the reader can gain a sense of direction and decide whether he or she wishes to study the entire course.

Although much fascination and enjoyment can come about through skipping from one chapter to another, we have decided that the material must be presented in a linear, syllogistic fashion in order to be completely understandable. This course is not intended to be difficult, except perhaps in the open-mindedness required to absorb the new viewpoints, and if the reader misses any point it is quite easy to backtrack to where the new information was introduced and refresh the mind.

The initial six chapters of this book are dedicated to covering the emerging, largely suppressed concepts regarding the existence of zero-point energy or aether. Since this energy is directly responsible for the existence of light, it is conveniently referred to as light by almost all major spiritual traditions.

Many ancient truths suddenly take on new definitions when we accept that we are walking, breathing and living in Light every moment. And the so-called material universe that we see all around us is made entirely of this Light - the idea of the atom as having a solid mass of any kind, and the idea of space being nothing but an empty vacuum are now archaic models at best.

Indeed, more and more researchers are coming to the conclusion that what was once believed to be "particles" in the atom are actually areas of sphere-shaped resonance or vibration within this fluid-like "aether" energy substance that exists throughout all space.

Dr. Milo Wolff's Space Resonance Theory and his book *Exploring the Physics of the Unknown Universe* provides an excellent model of this concept that has garnered some degree of mainstream recognition and respect, and we will be using it as a reference throughout the book.

The work of our colleague Rod Johnson will provide us with a dramatic unification of all experimental findings in the quantum realm through a totally geometric model of "aether" vibration, explained in the above abstract.

### **1.13 AETHER SCIENCE, FREE ENERGY AND ANTI-GRAVITY**

As we progress, we will clearly illustrate how the aether can be tapped for limitless free energy of many different forms, including gravity, magnetism and electricity. Clearly the implications of this new "aether" science are tremendous - it could dramatically assist us in saving the earth from destruction by eliminating the need for any type of fossil fuel, either for space propulsion or regular electricity.

And it is fossil fuel production, toxic combustion emissions and accidental spillage that is arguably the biggest cause of environmental destruction in our time - including the now all-too-obvious global warming and extreme weather effects.

And with the sheer implications of this new technology, for all intents and purposes it is only a matter of time before this science catches up with society, and there will be an over-abundance of those who can use it for engineering and intellectual marvels.

Although the suppression and killing has occurred before, the whole field is straining the boundaries and entering into public discussion - which all of us should be very happy about. With the huge uprising of the Internet, all suppression of science and truth will soon become as extinct as fossil fuel itself.

It is important to point out here that the material regarding aether theory, anti-gravity and free energy is already widely available on the Internet, with superb levels of research and documentation by qualified, credible Ph.D.- level scientists. Our research on this particular topic area alone has generated nine full-sized books worth of computer printouts, and that was only a fraction of the material that was available.

The true strength of this book lies in its successful compilation of a vast, multi-disciplinary amount of information, as even the most cutting-edge of these new "aether" theories are still missing some big parts of the puzzle. A synthesis of data on the order that it occurs herein has simply never before existed, and yet it will not go over the heads of the common educated public.

### **1.14 HARMONICS**

The essential point that most aether theories have missed is the idea that harmonics are totally fundamental in the aether's behavior. We will consider the aether to be a fluidlike energy that is constantly vibrating, spiraling in a motion that appears somewhat like a whirlpool, to create all subatomic "particles" moment by moment.

Once grasping this idea, we must then embrace the simple harmonic properties that are created in a vibrating fluid, such as water or air. And it is the all-important nature of these harmonic properties of aether that in turn affects all that we see in space and time.

We will show that all "dimensions" of space and time as well as all elements of our physical universe, both organic and inorganic, must function according to this simple aether behavior, which follows the precise numerical principles of harmony, resonance and vibration.

And so, with this short and preliminary overview in place, we are ready to begin our journey. For those readers who would like more specific information about the contents of each chapter and the order in which the material will be presented, we recommend reading over the chapter summary section at the beginning of this book.

We have deliberately avoided covering every aspect of the information in this Introduction in order to preserve the value of surprise for the reader and to provide further incentive to keep reading for the sheer thrill of discovery. So let's proceed!

## **1.15 RECAP**

**1.1** Virtually all world religions, spiritual faiths, secret societies and indigenous shamanic teachings insist that humanity is about to make a spontaneous, unprecedented stride in its material and spiritual development - a literal transformation of matter, energy and consciousness on all levels.

**1.2** Although we had originally considered *The Shift of the Ages* to be our final statement on the subject, we subsequently realized that it could go much farther with additional research. This book is our final summary of the new research.

**1.3** The persecution of Nicholaus Copernicus is still being mirrored in the harsh treatment of "frontier" scientific researchers today. The mainstream will vigorously defend any challenges to their prized paradigms.

**1.4** Science is very good at studying and explaining death - but very poor at studying and explaining life. Our new view of the Cosmos will show that the fundamental energy of the Universe is living and conscious; the Universe is an Ultimate Being.

**1.5** The beginning of an ongoing series of "disclosure" presentations for the UFO phenomena is about to be held on May 9, 2001. This may quickly lead to the final step of this information becoming publicly acknowledged, but continual media suppression is more likely.

**1.6** Some choose to fear these Visitors, though there is very strong evidence that at least the majority of them are here to protect us, and have been appearing before human cultures throughout all known history. Nevertheless, we are told that rogue elements within our military and governments are actively shooting down extraterrestrial spacecraft with advanced "Star Wars" satellite technology whenever they get the chance.

**1.7** Though the work of Edgar Cayce proved psychic ability beyond any shadow of doubt, many well-meaning "channelers" in the modern Internet community have produced wildly conflicting data, thus discrediting the entire field for many. This book will only use those sources that have clearly proven their validity, and only use their information as a framework to interpret straightforward scientific facts.

**1.8** Joe Mc Moneagle and others have proven that "remote viewing" is a phenomenon that really works. Mr. Wilcock used similar trance protocols to uncover the connections between the research data in this book, and also to fund our operations through "dream readings." Wilcock would not have been able to see how all these points fit together without this outside assistance, and thus this book truly represents an "extraterrestrial scientific disclosure."

**1.9** The Law of One series may represent the most accurate extraterrestrial communications in history. It is literally impossible that Carla Rueckert, the main channel for the information, could have produced such a complex, far-



reaching, scientifically and spiritually evolved body of work by herself. We cite eight different points that demonstrate Ra's accurate scientific knowledge, all of which came in advance of the corresponding scientific discoveries that followed.

**1.10** Ra indicates that there are galactic cycles of time that our Solar System naturally moves through, and in this book we will uncover the facts to back up this assertion. These cycles are said to be related to human soul evolution.

**1.11** The information in this book lends scientific credibility to Christian end-time prophecy. The reader is encouraged to absorb the information with the heart and remain open-minded about the possibilities of such a fantastic event occurring.

**1.12** We have decided that the material must be presented in a linear, syllogistic fashion in order to be completely understandable. Earlier chapters will cover information on anti-gravity and free energy, and these core concepts will then be expanded upon into understandings of higher planes of existence and new cosmological discoveries.

**1.13** The anti-gravity and free energy technologies could dramatically assist us in halting and even reversing the damages that we have caused to the biosphere. We suggest that even the most cutting-edge aether theories have still missed many big pieces of the puzzle, and in this book we will attempt to paint the most complete picture that is possible at this point.

**1.14** The properties of "harmonics, " or vibration, will be seen as having central importance in these new models of the Cosmos.

## **2.1 PHILOSOPHY: A NECESSARY FIRST STEP**

When the full implications of aether science become known to humanity at large, a very significant paradigm shift will be necessary. For this reason, a philosophical foundation that connects aether theory and consciousness must be carefully constructed, before the chapters that will discuss anti-gravity, free energy and other technological applications.

The readers who are not inclined to philosophy may not have thought about the issues of zero-point energy, unified field theory or aether science in the way that we will present them, which will incorporate many controversial scientific discoveries for emphasis.

For others who may not normally study science or physics, or even be aware of the work regarding aether theory, a significant effort and time commitment may be required to fully digest the material in this book. (However, from previous experience we already know that some readers will stay up all night and read it in one sitting!)

This is another valuable reason for discussing philosophy now; the non-technically inclined reader will have a much greater ability to see the context of the discussions that follow, and very likely have a far greater interest in working through the rest of the book, a chapter at a time.

We begin this chapter with a brief, preliminary investigation of the universal energy force whose existence is crucial to understanding everything in this book, technologically and otherwise. It is important to remember that this is only a very brief description, and will be enunciated in much more detail in later chapters.

After this initial description of the energy involved, we will cover the wealth of information that suggests its involvement within the arena of consciousness.

## **2.2 THE AETHER**

We live in a harmonic universe, built upon a unified, unseen foundation of conscious, loving energy, known as "zero point energy" or "aether." Up until the 20th century, all Western scientific tradition proposed that such an energy force existed, going back to at least the time of the ancient Greek philosophers, and most likely to a far older civilization with advanced scientific knowledge.

The existence of this aether was supposedly proven to be false by the Michaelson-Morley experiment (M-M) at the beginning of the 20th century, and most scientists still believe that it is correct. There are a number of reasons for why the M-M experiment is flawed, and for our technically-inclined readers, many of the researchers that we will be mentioning have detailed explanations of how it was misinterpreted.

We now know that an "aetheric" science is the only remaining model of the Universe that fits together with the evidence that is now available. Current theories working with these aether concepts, including "Sequential Physics," "Subquantum Kinetics," "Nonequilibrium Thermodynamics," "General System Theory," "Reciprocal System Theory," "Harmonic Universe Theory," "Maxwell / Whittaker scalar-wave physics" "Hyperdimensional Physics" and any number of "Unified Field Theories," all agree that our physical reality arises from this hidden energy substance, which creates all that we know and see by vibrating.

And thus, like fishes in the sea, the pressure of this energetic "fluid" constantly surrounds us, though we do not normally notice its presence. In this wealth of new data, the aether fluid is a source of tremendous energy that is in constant vibrational motion, flowing through all objects in the Universe, creating and recreating them every second --

just as a candle flame is constantly absorbing new wax and oxygen and radiating new heat and light, but still continues to exist as a measurable "unit."

Should this aether ever stop flowing and swirling about with such an intelligent, purposeful behavior, all mass would shed heat, gradually "dissolve" and return to its primordial energy state; the "flame" would go out.

Indeed, this new "physics of the 21st century" tells us that the very building blocks of mass, the atoms and molecules themselves, are not particles at all. Instead, they are ultimately nothing more than spherical whirlpools of energy in this flowing river of aether. And the aether itself provides the most tangible, scientific way to define, explain and even engineer the Mind of God.

### **2.3 DR. HAL PUTHOFF AND "ZERO-POINT ENERGY"**

It is important to remember that this new theory is not simply an abstract notion being entertained in the minds of amateur "crackpot" scientists working out of garage laboratories. Or, to put it metaphorically, this "pot" is not cracked at all; it is just about ready to fill up to the brim and start spilling over into the mainstream public consciousness.

The most significant forces that resist such a "disclosure" are arguably those connected to the fossil-fuel industry, as we will outline clear, irrefutable evidence that this technology can be harnessed for producing limitless "free energy" for all of humanity. Obviously a commercially priced anti-gravity system would render our entire fossil-fuel based world of cities, highways and transportation systems obsolete.

Furthermore, there is evidence to suggest that the wealthy elites are now aware that they / we will lose everything if we do not implement this technology; there is no point in maintaining financial control over an Earth that has been destroyed. Even the United Nations has come forward to state that our environment is on the brink of dire, irreversible catastrophe if we do not make immediate, painful changes.

This might be why visible cutting-edge physicists with government research backgrounds, such as Cambridge University's Dr. Hal Puthoff, are beginning to acknowledge that a modern "aether" science is required to explain the many problems and paradoxes of science. Drop by drop, we're being given the message by the mainstream media... and in this book we will hold nothing back, with full knowledge of the potential risks involved in doing so. Consider this a "sneak preview."

In order to lend proof to the idea that the "aether" really exists, Dr. Puthoff reminds us of experiments that were conducted before quantum mechanics theory ever existed, which were designed to see if there was any energy in "empty space." If these areas of the universe are truly empty, then nothing should be there; no electromagnetic fields, no X-rays, no heat, no energy, nothing.

In order to test this idea in the laboratory, it was necessary to create an area that was completely free of air (a vacuum,) and shielded from all known electromagnetic radiation fields. The shielding of this "empty" area from energy fields was accomplished by using what is known as a Faraday cage, which is lined with lead. This airless vacuum was then cooled down to absolute zero – the temperature where all matter should stop vibrating and thus produce no heat.

At this point, all conventional explanations, having to do with what physicists call the “conservation of energy,” would simply say that it should be a dead, lifeless “vacuum.” You’ve cooled it down to zero degrees Kelvin, sucked out all the air and shielded off all the energy fields. That’s it; now you’ve got a “dead” space.

These experiments proved that instead of an absence of energy in the vacuum, there was a tremendous amount of it! Dr. Puthoff has often called this a “seething cauldron” of energy in very high magnitudes. This force was dubbed “zero point energy” or ZPE.

The term “zero point” was used for two reasons. The first reason is that you can still find this energy at “absolute zero”, where there should be no heat or any other form of energy remaining. The second reason is that the pressures of this energy field usually cancel out to zero, or what is known as a vector zero resultant.

That complex-sounding term simply means that this energy applies force (vectors) equally in all directions, and thus to us it has no typically measurable movement or force; it just cancels itself out as a result.

However, Lt. Col. Tom Bearden points out that if you set two fleas into a head-to-head pushing battle and neither one of them can move forward or backward, you could measure the pressure in the area between their heads and have a vector zero resultant. However, if you measured the pressure between two elephants going head-to-head the same way, you would also have a vector zero resultant.

Therefore, Bearden suggests that different areas of space can have different pressures of energy, which are not normally noticeable or measurable to us. He refers to these invisible energy forces as “scalar waves,” and has built detectors that allow us to measure them, using coils that are shielded in Faraday cages.

So, if you’re still thinking that none of this matters very much in your own life, we’ll just give you an idea of exactly how high of an energy magnitude actually exists within the vacuum. Physicists John Wheeler and Richard Feynman have calculated that:

The amount of energy in the volume of vacuum space contained within a single light bulb is concentrated enough to bring all the world’s oceans to the boiling point!

Imagine, just for a moment, what might be possible if you could harness this energy for your own miracle healing power. Or for psychic ability. Or to levitate your own body, or other heavy objects. We are not afraid to say that the energy to do these things is already there! How many of our readers will completely discount every reported miracle of Jesus and other spiritual adepts and masters?

If you resist the idea that such possibilities exist, then this book is probably not for you. Lt. Col. Bearden reminds us that when we tap this energy for our own needs, it is the equivalent of dipping a teaspoon into the ocean. This limitless reservoir of energy around us is of far greater magnitude than we could ever dream of.

Once we accept this energy’s existence, many problems in quantum mechanics clear up. The very existence of atoms, as now seen in quantum mechanics theories, cannot be adequately explained with our existing models. (We will have much more to say on this as the book progresses.)

Dr. Hal Puthoff notes that mainstream quantum mechanics theory does not understand why an electron does not simply radiate away all of its energy and crash into the nucleus, as a satellite will eventually do in Earth orbit. If there is such a thing as an “electron,” it would indeed appear to be akin to a tiny perpetual motion machine.

When asked, quantum physicists will usually just say that this strange behavior is "the magic of quantum mechanics." Problematically, they propose a 'closed system' where energy is radiated out but no new energy can come in, even though every physicist knows that "Energy can neither be created nor destroyed."

However, if the electron itself were constantly drawing energy from the ZPE or aether, as Dr. Puthoff suggests, then it would be able to sustain itself as an 'open system' just like a candle flame, where energy is constantly flowing in and flowing out.

## **2.4 AETHER: NOT TOO TABOO**

More and more researchers are unafraid to use the forbidden word "aether" when discussing zero-point energy, this flowing background substance of the Universe that can be proven to exist everywhere. The word "aether" had essentially become "taboo" after the Michaelson-Morley (M-M) experiment supposedly disproved its existence in 1887, even though all it truly did was to disprove the existence of a material aether, which would be a literal physical substance of matter that was hanging in the air like a gas.

The original idea for this experiment was not to prove or disprove the aether's existence; it was simply to measure how much was there. The experiment proposed that as the Earth moved through space, there would be a "drag" of aetheric substance that could be measured in the direction of Earth's travel, similar to ripples on a pool of water as you move your hand through it.

There are several problems with this being used to "disprove" that there is an aether. Firstly, conventional science does not understand that gravity is the primary movement of aether on Earth that we can measure, which overrides the "aether drag" of Earth's movement through space. To a person inside the gravitational field, gravity would be the only noticeable aetheric movement; it shields us from other movements.

Secondly, they did not realize that the aether was also forming the measuring instruments as well as the measurement area, thus making any measurement of such subtle changes impossible! Any change in the surrounding area will also produce a change in the instrument itself.

Even though M-M did not disprove the existence of a non-material energy source such as ZPE, even the use of the term "aether" now is likely to create automatic rejection from society's scientific authorities. As long as people continue to "believe" in the scientific fraternity's inherent trustworthiness without examining the facts for themselves, this game can be perpetuated.

Even though we cannot "see" the aether directly, we also can't see the bacteria on our skin, the air that we breathe or the gravity that holds us to the Earth. Thus, even though one might feel that something "nonphysical" means that it cannot exist, all it really means is that it is not directly perceptible with our natural sensory organs.

Prior to Michaelson and Morley's experiment, most physicists agreed that this aether had to exist, and created workable models and mathematical constructs based on it. And now, the "negative" result of the M-M experiment has been superseded by a plenum of findings that prove that the ancient concepts were right all along.

The difference is that we now know that atoms and molecules are composed of nothing but electromagnetic fields, whose energy comes from a source that is not yet measurable with most conventional methods!

Therefore, whereas Relativity and Quantum Mechanics were the hallmarks of 20th century physics, stalemated with obvious contradictions and impossible Babylonian towers of increasingly contorted logic, a modern interpretation of the "aether" will rapidly rejuvenate physics with new, orderly life in the 21st century, returning the Universe to an understandable Unity where we "know the playing field."

## 2.5 A VIBRATIONAL VIEW OF GOD, LOVE AND PHYSICS

As our understanding of this universal energy source continues to expand, we are soon confronted with the idea that it is intelligent, that it can directly interact with our consciousness. After all, if this truly is the "Unified Field" that mainstream science has been searching for as the basis for all matter, then we are also a part of that unified field – mind, body and spirit.

Or to put it in different terms, since we have consciousness, then consciousness must be a functioning part of that unified field as well. This simple point of philosophy is quite often ignored in the course of a scientific investigation:

By virtue of the fact that consciousness exists, it must be a function of the Unified Field, whatever that turns out to be.

And in his book *A Brief History of Time*, well-known physicist Stephen Hawking predicted in the late 1980's that this Unified Field Theory would be solved within twenty years.

The concept of a consciousness that is inherent in the energy of the universe is no longer in the realm of the spooks and spiritualists, as modern quantum physicists have discovered irrefutable evidence that the expectations of the experimenter can dramatically affect the outcome of the experiment – the quantum energies involved "know that they are being watched."

Anyone can go to the science section of their local bookstore and find scores of titles that will discuss this, such as the classic *Dancing Wu-Li Masters* by Gary Zukav, who is now well known for his frequent, insightful appearances on the Oprah Winfrey show. Furthermore, we also know that this conscious interaction with "matter" doesn't have to stop with the quantum arena.

In the field of parapsychology, which is solidly empirical and has struggled in vain for mainstream academic acceptance for many years, we have prestigious institutions such as Princeton Engineering Anomalies Research or PEAR that have absolutely proven that human consciousness can affect the outcome of seemingly "random" procedures. This can include effects where the participant is able to demonstrate the following, statistically significant results:

- affecting computerized random number generators,
- changing the speed with which radiation emanates from a source to be measured by a Geiger counter,
- and even affecting the random movement of ping-pong balls through a matrix of pins. The experimenter drops the balls through a single slot into a matrix that normally should funnel them into a random configuration throughout ten or fifteen slots at the bottom, and yet by sheer intent the participant is able to significantly increase the number of ping-pong balls that fall into a certain slot.

It is also important to remember that the subjects for these sorts of experiments are not heavy-duty psychics, but ordinary people; so we are not talking about something that is only available to certain "elite" humans in our society.

These experiments clearly reveal that the human being possesses untapped potential that has not yet gained mainstream scientific acceptance.

So therefore, if the entire Universe is composed of a unified field, or One Unified Conscious Energy Source, then as we said, we are also a part of that field; our consciousness can interact with it at many levels.

Though many of us have not reached consensus about who or what God actually is, we must also follow the logic and admit that all of our most fundamental conceptualizations of God must be considered in this model as well.

When we strip away the religious and denominational distinctions of various belief systems on the planet and try to weave a single thread through their teachings, we are left with the simple fact that the fundamental nature of God's Energy is Love and Light.

Since its nature is loving, we are told that it seeks to have everyone else feel the same way; it is continually striving to have each conscious life form in the Universe reunite with that Love and Light as much as possible. Hence, Jesus taught us to "Love thy neighbor as thyself." We are told that God is evolving, through the free-will decisions of its apparently separate participants. The whole universe changes as we choose to reunite in Oneness.

The key point that can connect the concepts of God, Love and physics is the idea of sympathetic vibrations, as researcher John Keely suggested. Keely reminds us that this principle is easily seen with a tuning fork.

If you strike a tuning fork and have another nearby of similar proportions, the sound vibrations will mysteriously "carry over" to the non-vibrating fork and cause it to resonate on its own. Similarly, we have different people, different nations, different planets, and we can either choose to love and get along with each other, or choose to hate and destroy each other.

So, in the simplest possible sense, we can either have faith or simply postulate that the entire universe is One Being with One Mind, and that both the nonphysical aether and physical matter is all a fundamental part of that interconnected being. The world's spiritual teachings all tell us that God seeks Oneness, unity and connection, and they also associate this quite directly with the concept of vibration.

To use an analogy given by Dr. Walter Russell in *The Secret of Light*, we can take a single wire, bend it 90 degrees and begin rotating it. At slower speeds we can easily see the wire, but the faster we vibrate it in circular motion, the more it will appear as a completely solid disc.

This is a model for how our apparently solid matter could be seen as ultimately composed of non-solid energies vibrating at a certain frequency, but it is also a model that allows us to see how the higher the vibrations rise, the more stable and Unified their composition will become.

Therefore, Unity or Oneness is the point of "singularity" where all vibrations become simultaneous: all colors become White Light and all space and time merges into a single "moment center" – which we will cover later in the book. Again, the closer we get to the "moment point" of Oneness, the higher the vibrations will become – and the model of physics in this book will show us very concretely how this is working, if we are willing to accept that simple philosophical premise.

And thus, even though love is often seen as merely a nebulous, subjective concept that often gets tied up in ideas of control and sexuality, in the aether models it can very well be defined:

Love is the tendency for entities within the Unified Field, whether human, “particle” or otherwise, to increasingly vibrate towards Harmonic Unity or Oneness.

So, you ask, what does love in the human being have to do with vibrational movement? There are several ways to look at it. In a more physical sense, the feeling of love causes more motion in the nervous system and throughout the body: pupils dilate, heart rate accelerates, skin conductivity changes, perspiration increases, breathing is accelerated and neurological processes flow more quickly, leading to greater inspiration.

Moreover, the feeling of love will bring a human being into greater harmony with the others around it; there is a greater propensity to smile, to be happy, and to be friendly. In a very real sense to many spiritual philosophies, this creates a radiant motion, as when love is radiated to another person, that person also begins to feel it, and is likely to continue radiating it to others.

This radiant motion could be seen to travel through humanity in much the same way that a wave exhibits motion through a given medium, though it may not seem to be a fast-moving wave on the time axis. (At least, that is, until we study the Maharishi effect, which is covered further along in this chapter.)

Indeed, the ETs tell us that at any one time, the total mass of humanity has a strong hand in determining the total vibrational frequency of the earth, whether higher or lower; so “everyone counts.”

We have stated that this motion of Love is a factor in physics, such as at the quantum level, as well as in human beings. Consequently, the aether that forms all objects in the Universe must be in motion. But why must there be motion, you ask? Without motion, there is no Existence.

If ultimately the universe is comprised simply of a Unified Field, then something has to happen within that field to create change – it can’t just “sit there.” In other words, if the field remained static, unmoving and unchanging, then you couldn’t build reality, as on the most fundamental quantum level, energy has to move in order to function.

That movement is a vibration; therefore, all elements of this Unified Field could be seen as existing fundamentally as vibrational motion.

If the nerves in your brain were not capable of vibrating energy through themselves and into the appropriate areas, you would not be able to think or operate your body in any capacity. If blood did not vibrate through your veins by the action of various muscular contractions, you would die.

If electricity is not allowed to vibrate through the circuit boards of your computer, the computer will not function. If the energy in atoms did not move, we couldn’t perceive them and they couldn’t bond with each other to form basic chemical compounds.

So for you, the human being, it is important to see that in a very direct neurochemical sense, every thought and action, however small, is creating a form of vibration in the aetheric energy that surrounds and creates you.

If the electrical interactions in your brain and body were only occurring in the context of “empty space” surrounding you, then you might not expect them to travel outside of the barrier of your skin to the air– but we now know that there is no empty space in the Universe. If all energy is unified as one field, as aetheric energy, then any movement of energy within that field must resonate throughout it – including the movement of consciousness.



Think about it this way. Your body couldn't function very well if each cell declared itself separate from the body and shut down, refusing to "vibrate" with the rest of the body systems. It is for this simple reason that the world's spiritual teachers all suggest to us that God has an agenda, seeking to reinforce the loving, unifying thoughts and actions.

How could one part of the body rage against another if the body is to perpetuate itself through cooperation? No one can deny that each one of us wishes to be happy – it is written directly into the Constitution of the United States as one of our most fundamental "rights." Why should God be any different?

So, if your consciousness is actually creating "ripples" of vibration in this sea of nonphysical aether energy, then the more loving you become, for yourself and for others, the more this causes you to strengthen your vibrational fusion with the energy of Creation. And ultimately, this fusion is a point of no space / no time and all space / all time. Geometrically, it is the Center.

Love is a radiating, strengthening, unifying force, moving towards the central point of Oneness, whereas hate, or the absence of love, is an absorbing, dis-integrating, weakening force, absorbing energy away from the central point of Oneness and compartmentalizing it.

Though many people will probably disagree with such an assessment of the vibrational nature of consciousness, it is certainly something that deserves a fair trial, especially in light of the scientific evidence that we are about to cover.

This importance of "love as vibration" is by far the most fundamental spiritual message that the positive ETs seem to be attempting to impart to humanity through any number of methods, such as the phenomenon of "psychic readings."

So, although it does indeed bend the mind somewhat to think of Love as an actual tangible energetic movement, there are an ever-increasing number of people who are working on their spiritual growth and healing processes who speak about this "energy" constantly. Even as science is making great strides in many very important ways, we must also respect how many spiritual strides are occurring in our society as well.

More and more of us are becoming cognizant of the bigger pictures that define reality as we know it -- and we are not afraid to follow the clues to their new solutions. Science no longer needs to be compartmentalized to the degree that the physicist goes to church and prays to God on Sunday, and then spends the rest of the week in the laboratory trying to disprove its existence.

## **2.6 THE BACKSTER EFFECT REVISITED**

Indeed, the conscious aether itself is arguably the most direct energetic manifestation of God that we will ever find – and as we have said, all spiritual traditions seem to agree that God is Love and Light.

Certain replicable experiments, including Cleve Backster's various polygraph experiments with plants and other forms of life, and a host of mind-body medicine studies in humans, reveal that hatred destroys life and love enhances life.

Although we could argue about the cause, the fact remains that when a human being sends harmful thoughts to a plant, it goes into great alarm and shock and will eventually wither and die, whereas other equally valid experiments showed that if a human being sends love to a plant and / or plays music around it, the plant will blossom and grow more vigorously.

This methodologically sound research was originally highlighted in the extremely popular 1970s book known as *The Secret Life of Plants*, and more recently in another book known as *The Secret Life of Your Cells*, by Dr. Robert Stone.

The “Backster effect” demonstrates that plants are very well attuned to the energetic vibrations within their environment. It has been demonstrated and recorded countless times, eliminating all extraneous variables with strict design protocols.

Cleve Backster had many years of police experience in administering “lie detector” tests, where a human being would be set up to a machine that measured minute electrochemical changes in the skin. This process, known as polygraph testing, would produce data in the form of a continuing graph on paper, similar to a measurement of heartbeat or other vital signs.

The stylus that deposited ink on the paper was designed to wiggle in accordance with any changes in the person’s Galvanic Skin Response, or GSR, which is basically a measurement of how well the skin conducts electricity.

If the person suddenly felt the internal stress of telling a lie, their physiological system would reveal that stress through such things as an increase in heart rate, breathing and perspiration. Any of these increases would change how well the skin could conduct electricity, and often quite abruptly.

So, after many years of work in this field and becoming one of the top polygraph experts throughout the country, Cleve Backster got the idea one day to delicately connect the same metallic terminals that he normally would connect to a human being for a “lie detector” test to the leaf of a plant, and graph the plant’s electrochemical changes.

Over time, he discovered that the plant was somehow responding to its environment quite directly; anything that may damage the plant in the outside world seemed to cause a reaction. Cutting the plant seemed to be nowhere near as traumatic as burning the plant, however if he pretended that he was going to burn the plant but knew that he wasn’t actually going to do it, the plant wouldn’t respond.

It was only when he formed a clear mental image of grabbing a book of matches, lighting a match and holding it to a leaf that the graph would register a sudden spike – the plant was going into shock, sending as much extra moisture as possible to the leaf in order to protect itself against any damage. This effect also ripples throughout all other plants in the vicinity.

Some will dismiss this research out of hand, no matter how many charts and graphs they are shown, or even if it is demonstrated right in front of them. On the other hand, other people who are more open-minded would choose to interpret this experiment as indicating that the plants are thinking creatures just as we are.

However, at the most fundamental level, we must consider that either way, there has to be a means by which the thoughts of the human are being transmitted to the plant – there has to be a medium through which consciousness can travel. Mainstream science has not yet acknowledged the niche where this medium would exist; namely aether or zero-point energy.

Novel theories of a chemical “message” being sent through the air are certainly possible, but the effect works just as well when the plants are isolated from each other, thus prohibiting any such form of communication.

So again, let us use our example of love as representing a higher level of vibration in the aether. The plant may not have any “emotions” as we would think of them as humans, but simply is responding to changes in the vibrating resonance of aether that constantly surrounds and thereby creates it on a moment by moment basis.

In other words, when a person sends loving thoughts to a plant or plays it music, the aetheric energy that the plant draws on for growth and development is increased, and it thereby becomes more vigorous. Similarly, when Backster sent hateful thoughts to the plant, the frequency of energy around it actually decreased, and based on the plant's primitive design, this energy change triggered a natural survival response as a result.

Backster also demonstrated that the plant's shock response could just as easily be caused by the suffering of other creatures in the same area. He designed a series of experiments where a machine would randomly dump brine shrimp into a bath of boiling water while he was not present in the building.

The plant naturally and immediately responded to the death of brine shrimp in its environment, reacting with the electromagnetic vibrations that were present in the area; it wasn't necessary for a human to send negative thoughts to the plant.

Hence, inharmonious aether vibrations, no matter who or what creates them, could be seen as leading to inharmonious and even toxic growth conditions, whereas loving aether vibrations enhance the speed and vigor of vitality that streams into the plant, as other experiments clearly demonstrated. Pain, death and hateful thoughts draw away energy from the aetheric forces in that area and reduces the plant's ability to grow.

The Backster effect has also been demonstrated with bacteria – an even simpler lifeform than brine shrimp. We attended a lecture of his that was hosted by Walter Russel's University of Science and Philosophy on September 8, 2000.

During this talk, Backster revealed that he discovered the bacteria effect after pouring a pot of boiling water from the coffeemaker into the sink in his laboratory. His plants, which were always connected to the polygraph machine, registered a huge and immediate shock when he did this, which he later found on the printout.

Obviously, he was very puzzled as to what had caused this at first, and had to think carefully about what he was doing right at the moment that the shock had registered. Once he traced it back to the boiling water, he sampled the sink with a cotton swab and analyzed the specimen under a microscope.

He then got the answer, which was that a huge colony of bacteria was growing in the sink, which he did not clean regularly! Subsequent experiments proved that the plants consistently reacted to the death of the bacteria. This unexpected result was what led him to perform the brine shrimp experiments indicated above.

### **2.6.1 "LIVE FOOD"**

From this point, he later determined that yogurt could be used in his experiments in place of plants, due to the living bacteria cultures within it, and it would perform in exactly the same manner. The conductivity of the yogurt allowed him to put electrodes into it in the same fashion, and he was able to measure similar polygraph reactions as the plants had shown.

For example, when he had connected the yogurt to the polygraph and then had someone eat a separate yogurt sample, the yogurt would register a shock reaction perfectly in time with the small number of seconds that it took the digestive juices of the stomach to begin breaking it down. Likewise, yogurt in a given room would respond to anything damaging that happened to a plant nearby.

### 2.6.2 PLANARIA

At one point, Backster attended a scientific presentation that involved the Planaria worm, a small centimeter-long flatworm with two knobby “eyes” at one end of its body. In this experiment, the researchers were attempting to prove that knowledge from one worm could be transferred to another worm that had eaten the remains of the first.

So, the hypothesis was that if a Planaria “learned” not to go to a certain area that would damage its body, that knowledge would become stored in its cells and could be transferred to another worm that was fed the remains of its body.

The first Planaria would be placed in a petri dish that had a caustic chemical at its rim, so it would learn through hard experience not to travel to the edge. After learning this lesson well, it would be diced up and fed to the next worm. The researchers would connect polygraph electrodes to each Planaria that was placed in the dish, in order to register the occasions when it was being shocked by contacting the chemical.

*“Do you want to know what’s really going on?”* Backster asked the lead researcher.

*“Sure,”* the researcher challenged.

*“Watch this,”* Backster said. He went over to the flask that contained the whole colony of Planaria worms and gave it a good shake back and forth. The Planaria in the dish gave such a huge reaction that it spiked the graph right off the paper!

The researcher immediately dashed over to the graph and started checking underneath the machine for a loose wire or a malfunction; Backster simply laughed, put his hands in his pockets and walked away. Simply put, what happened to one Planaria happened to all the Planaria, and a primitive form of “group consciousness” traveled through supposedly empty space, seeking to teach the group its lessons for survival.

### 2.6.3 CELLS

Backster’s studies involving human cells, as documented in Dr. Robert Stone’s book, are perhaps even more interesting. In this case, the epithelial (skin) cells of a human being, gathered from inside the cheek with a cotton swab, were stored in a separate room and connected to a polygraph machine.

Backster was able to prove repetitively that the cheek cells would demonstrate sudden responses that corresponded precisely with the timing of tailor-made emotional shocks that were carefully induced to the participant. It wasn’t necessarily easy to ethically shock a human being, so there was no “standardized” way to run the experiment.

The tailored shocks were administered through such methods as the viewing of violent movie footage that would have a particular emotional impact to that individual, such as a World War Two fighter pilot veteran watching a film of an airplane being shot down.

In such a case, as the ex-pilot squirmed in his chair, creating electromagnetic frequency changes in his Galvanic Skin Response, his cheek cells would squirm in the next room in the same measurable way. Another example would be to

leave a young man in a room with a pornographic magazine, and to then barge into the room after he had started looking at it, creating a rush of embarrassment.

His cells showed the same response in the next room. Therefore, shocks and negative emotions in the mind are instantaneously moving throughout the cells of the body and affecting them, whether those cells are connected to the body or not! If space has no medium in it that allows consciousness to travel from one area to another, then how could this be possible?

## **2.7 CLASSIC METAPHYSICAL MYSTERIES EXPLAINED**

### **2.7.1 CANCER**

Backster's findings with our cells help explain the fact that cancer is now shown by medical professionals such as Deepak Chopra and Andrew Weil to be a direct manifestation of anger, or the resistance to love.

These studies also reveal that those who are the healthiest and live the longest are also the happiest and the freest from worry, fear and hatred, thereby accepting love into their lives. In other words, stress and shock are not simply isolated from the bodily system; they fundamentally affect all cells of the bodily system.

What had once seemed to be metaphysical speculation is now becoming an established medical fact. If you want to live longer, you need to have effective stress management skills, and learn how to communicate effectively to dissipate your anger.

### **2.7.2 THE MAHARISHI EFFECT**

Furthermore, if the Backster effect can occur within the cells of one person whether the cells are within or separate from the body, then it is foolish to assume that this effect is not also passed between human beings to some degree as well, then directly affecting the emotional states of others around them.

This is one reason for why very sensitive, intuitive people can end up having constant battles with depression; they are unable to "shut off" the disharmony of the people around them.

And on a more positive note, the highly well-crafted "Maharishi effect" experiment showed that while a large group of trained people meditated together in a major city, the amount of violent events in that city noticeably declined.

A good, short account of this experiment is featured in the book *Cosmic Voyage* by Dr. Courtney Brown, head of The Farsight Institute:

In the December 1988 issue of the *Journal of Conflict Resolution*, a methodologically sophisticated article appeared which claimed that groups of meditators practicing Transcendental Meditation and the more involved TM-Sidhi Program in one place could influence the level of conflict in nearby locations (Orme-Johnson et al. 1988).

This phenomenon is labeled the “Maharishi Effect” in honor of Maharishi Mahesh Yogi. The article was considered controversial when it was published, and by all accounts it still is.

Again, what we are fundamentally seeing with this effect is that there is a medium that human consciousness travels through; and indeed, it may be the very formation of that consciousness as well. In an aetheric model, this movement could simply be seen as what we have defined as Love: **“Love is the tendency for entities within the Unified Field, whether human, “particle” or otherwise, to increasingly radiate Harmonic Unity, through vibrational motion.”**

And in the case of the Transcendental meditators, somehow the process of stilling the mind, having loving thoughts and breathing deeply is causing there to be a raising of vibration, which then ripples through the consciousness of humanity much as the lowering of vibration through pain had rippled through the Planaria worm family in Backster’s demonstration.

So, if you are willing to still your mind in loving consciousness, you may very well be able to cause a movement of the energy around you. But exactly how much motion is a human being capable of creating in this aether?

If all physical objects are created from this energy as well, then must this only remain a movement within consciousness, or could it be physical motion as well? (In later chapters we will discuss the motion of aether to levitate physical matter through technological means, and show clear, documented evidence that proves that this has already been done.)

### 2.7.3 LEVITATION

Indeed, some of those on our planet are already developing the abilities that are said to be commonplace in higher realms of vibration - abilities such as ESP, precognition, levitation, spontaneous manifestation / demanifestation of objects, the ability to see auras, heal others and the like, all of which can occur in the aetheric model. Numerous Christian saints were eye-witnessed and documented as levitating, such as St. Teresa (1515-82) who said the following:

It comes, in general, as a shock, quick and sharp, before you can collect your thoughts, or help yourself in any way, and you see and feel it as a cloud, or a strong eagle rising upwards and carrying you away on its wings.

This author and others have personally felt the preliminary stages of what St. Teresa was describing, including a “quick and sharp feeling before you can collect your thoughts” and a feeling that “your soul was carried away” through the top of your head. Wilcock has named this phenomenon the “ear blast,” since it seems to originate as a pulsating vibration in the ears that causes, or is a result of, a sudden, shocking vibrational increase in consciousness.

In our case, this has never gone fully into levitation of any kind, but there is still hope! Mainstream Catholic records report that St. Joseph of Cupertino (1603-63) was literally able to fly eight or more feet above the ground, and this was publicly observed over 100 times.

Once he also grabbed onto another friar and carried him around the room, and soon after his death, fellow witnesses confirmed under an oath before God that they had seen St. Joseph levitate. It is highly unlikely that they would have lied, given what such an oath would have meant for them.

More recently, we have the case of Mr. DD Home who has also been documented as levitating his body in the 19th century, by reputable scientific researchers, world leaders and crowned dignitaries who observed it firsthand in the eastern Lake Ontario, Canada area from 1820 to 1850.

Not only could Home levitate, he could perform many other feats, including plunging his hands or head into fire and not getting burned, and even levitating an accordion inside of a cage and playing a tune on it. Michael Talbot's book *The Holographic Universe* contains a treasure-trove of fascinating accounts just like this one, and should be considered "required reading" for those who truly wish to study and integrate this new paradigm.

Regardless of what any particular reader is willing to believe regarding metaphysical phenomena such as levitation, there are certainly an ever-increasing number of people who are having valid mystical experiences and are reluctant to discuss them in public for fear of ridicule.

In October 2000, an otherwise ordinary furniture salesman revealed to this author that his son had levitated three feet off the ground in a well-lit room during a séance – and it was only after Wilcock revealed the truth of his career and findings that the man had enough trust to offer the information.

Naturally, a skeptic will just continue to say "He's lying" unless the proof is individually witnessed – other certified witnesses such as in the case of St. Joseph of Cupertino are ignored.

However, now we can loosen those shackles, as the existence of the conscious aether makes all varieties of mystical phenomena possible, by providing a medium for consciousness to travel through and thus cause action-at-a-distance, even to the point of causing the direct levitation of objects or the human body. And telekinesis has very definitely been studied in the laboratory setting.

## **2.8 THE AETHER AND PSYCHOKINESIS**

If a human being can make objects levitate and move through "empty space" by themselves, then our current scientific understandings are in need of serious revision. As we said, if love is simply a motion of energy that trends toward a higher level of vibration, then this might not have to be a motion solely within the nonphysical field of consciousness; physical matter can be affected as well, even to the levitation of the body.

However, the data on levitation is still open to other interpretations, some of which are simply religious and do not bother with the question of "how." In the mind of the scientist, the universe is composed of four basic forces: gravity, electromagnetism, weak nuclear and strong nuclear force.

If the aether truly forms all of physical matter and either creates or is a function of consciousness, then there must be a way for consciousness to spontaneously generate any of these four basic forces we have cited, in addition to being able to move physical objects. If we can't find the basic forces of the Universe created in this movement of consciousness, then the entire, widespread body of data "can't be true."

Rigorous studies of the phenomenon of psychokinesis were conducted in the former Soviet Union and Czechoslovakia, later reported on in the unclassified Defense Intelligence Agency's Soviet and Czechoslovakian Parapsychology Research (U), by Mr. Louis F. Maire III and Major J.D. LaMoth, MSC, published September 1975.

Since it appears that these countries were far ahead of the United States in this research, it is worthwhile to pursue these leads -- as most Westerners are not aware of the degree of scientific progress that has been made in the former Soviet bloc on these areas. In these studies, the aetheric energy being harnessed is referred to as "bioplasma." We have italicized certain portions of this rather long excerpt below for emphasis:

Psychokinesis (PK), or as it is sometimes called, telekinesis, is the ability to influence animate or inanimate objects at a distance, without physical contact, by means of uncontrolled or controlled biological energy fields.

Some, but not all, of the effects of PK include: initiation or cessation of motion in inanimate objects; apparent neutralization of the effect of gravity on inanimate objects (levitation); induction of changes in physiological processes of animate matter; the creation of measurable electric, electromagnetic, electrostatic, magnetic or gravitational fields around target objects; and the imposition of images on shielded photographic emulsions...

[Note: Right away, the criteria for human consciousness to create the basic energy fields in the Universe has been satisfied, published in a document from the US Defense Intelligence Agency.]

Soviet research has taken several different directions in efforts to develop materialistic explanations for observed PK effects. This research has involved in-depth studies of the characteristics of the electrical field between subject and object, characterization of electrical fields immediately around the subject, study of bioelectrical fields by detection devices, study of subjects' brain wave patterns, and photography of the subjects' bioenergy fields.

To date, Soviet scientists are by no means in accord concerning the nature of the forces involved, but **all are in agreement that a physical energy is at work.** (37)

Dr. Viktor G. Adamenko of the Moscow Institute of Radiophysics, Dr. Viktor Inyushin, of the Kazakh University, Alma-ata, and Dr. Genady Sergeyev of the A.A. Uktomskii Physiological Institute, Leningrad are the leading Soviet theoreticians studying PK.

Both Inyushin and Sergeyev have developed theories based on the existence of a new form of energy -- a form of biological energy referred to as "bioplasma". They consider PK effects as analogous to lightning accidentally charging a surface and feel that movement in PK occurs as a result of the interaction of the object's electrostatic charge and electromagnetic field with the human operator's field.

The biological energy involved is under conscious direction by the subject, who can make a target object start or stop motion, change direction or rotate. Sergeyev has developed instrumentation which measures



changes in the bioplasmic field at distances up to 3 meters (9.9 feet); he has recorded fields of 10,000 volts/centimeter in the vicinity of a target object with no indication of an electrical field in the space between the subject and the object.

According to Sergeyev, bioplasmic energy is maximally concentrated in the head region. He attributes PK to a polarization of the bioplasma in a laser-like fashion and refers to this as a "biolaser effect" which acts as a material force upon the object. (37)

Dr. Sergeyev has developed detectors that monitor the energy field during PK demonstrations. Although Western observers have been denied information on the construction of the detectors, (information reported to have been classified by the Soviet military,) details may have been published by the Soviet Academy of Sciences...

[Note: At this point the authors try to speculate as to what these detectors might be. We have omitted this portion and certain others. When we review Lt. Col. Tom Bearden's work on Soviet scalar-wave technology we can see why it was classified, as he has written entire books on how the former Soviets had used this technology for weapons applications.]

Dr. Adamenko has conducted experiments to ascertain the role of electrostatic charges on the surface of target objects as the cause of their movement... Adamenko has shown that the material basis of contactless interaction between man and objects results from an electrostatic field whose magnitude depends on man's physiological state...

...Adamenko makes reference to healing by "the laying on of hands" (in Western terms "faith healing"). The Soviets have measured electrical fields between "healers" and patients, yet knowing these field potentials they have not been able to duplicate the beneficial effects obtained from humans by means of mechanically generated fields...

In 1973 and 1974, a Soviet psychic named Boris Ermolayev participated in a series of experiments at Moscow University. Ermolayev is reported to have the ability to levitate (suspend) objects in midair by concentrating psychic energy at a focal point in space. (40)

In some of the tests, Ermolayev pressed an object between his hands, then slowly moved his hands apart until they were approximately eight inches from the object, which remained suspended in the air.

Soviet scientists claim that all tests were conducted under the strictest controls and that no strings or other devices of any kind were used. Dubrov feels that Ermolayev's levitation powers can be used to prove that space-time and gravitational changes occur in the area between the psychic's hands and the object.

He suggests that the transmission of electromagnetic energy of known velocity should be delayed when beamed through the levitation field.

Two female subjects, Nina Kulagina and Alla Vinogradova, have been studied extensively by Drs. Sergeyev and Adamenko. According to Sergeyev, Mrs. Kulagina can control the beat of frog heart preparations, imprint images on shielded photographic emulsions, and move objects weighing one pound or more...



Nina Kulagina in the laboratory with objects that she moved while being filmed

[Note: Refer [here](#) for other images.]

In other experiments, Mrs. Kulagina imprinted images on unexposed film sealed in black envelopes. During these experiments Sergeyev measured the energy around the psychic's body and found it to be half that of a non-psychic individual. This led Sergeyev to believe that she absorbs, or draws, energy from around her and then discharges it on the target object.

Mrs. Kulagina experiences considerable stress while she is being tested. Her pulse increases, as does her rate of breathing; she develops pain in her upper spine and the back of her neck. At the onset of her "activated" state she feels thirsty and has a taste of iron or copper in her mouth.

During the activated state she experiences occasional periods of dizziness and nausea. Her blood sugar level rises and within one hour following cessation of tests, a loss of weight (1.5 - 2.0 lbs.) occurs. She experiences less stress when alone, and claims to respond best in an atmosphere of friendly mutual trust and belief.

Her PK ability is mood dependent (her mood and the mood of the observers) and she expends more energy in a hostile or skeptical atmosphere.

The mechanical aspects of Mrs. Kulagina's PK effects are as follows:

1. Size and shape are more important than the physical structure of the substance she is trying to influence.
2. Weight and dimensions of objects she is trying to move are important; the weights vary from a few ounces to nearly one pound.
3. She finds moving a vertical cylinder easier than moving a horizontal one.
4. She causes no changes in the shape of soft objects during movement.

5. The direction an object moves depends on her will, and may be either toward or away from her. She can also cause rotational or vertical movements to occur.
6. Kulagina's optimum field effect occurs at approximately 1 1/2 feet; her distance limit is approximately 3 feet and 4 inches, when the object to be influenced is 3 feet from the edge of the working surface. At these distances she is said to be able to move one object out of many, depending upon where she centers her concentration.

The electrical aspects of Kulagina's effects are as follows:

1. An electrical field is generated in the vicinity of the object she is attempting to influence; however, there is no measurable field between Kulagina and that object and no sparks are observed.
2. She can exert no effect on an object situated in a vacuum.  
[Note: Other Soviet psychic research had clearly demonstrated that this "bioplasmic energy" can travel through anything, including lead-shielded cages which prohibit any conventional radiation from entering.]
3. Electrostatic screening has no effect on her powers, which seem to be better with the object under a dielectric [non-conducting] cover, but she is unsuccessful during storms or other atmospheric conditions when there is a greater than normal amount of electricity in the air. She cannot, at any time, exert an influence on an electroscope.
4. She can cause luminescence of crystal lumiphors and produce changes in the spectrum of visible light absorbed by liquid crystals.

Dr. Adamenko has found that Alla Vinogradova produces effects similar to those of Nina Kulagina, but undergoes far less physiological stress. In some of his experiments with her in Moscow, during which she moved a variety of objects about on a dielectric surface, a great deal of electrostatic (ES) energy was measured around the objects (supposedly enough to light a small neon glow tube).

The measurements detected field pulsations which were synchronous with Vinogradova's respiration rate, heartbeat, and brain alpha rhythm pattern; however, the region between Vinogradova and the object contained no energy fields nor frequencies, and the ES energy increased in intensity as the objects were approached.

The results with Alla Vinogradova have led Adamenko to believe that there may be individuals who have the ability to build up an ES field on the body surface at will and project it as required. (38)

[Note: At this point in the document the authors take several pages to describe Czechoslovakian research into PK that can be done with most people, not just exceptional individuals.

This typically involves a lightweight object that hangs downward on a string attached to its midpoint and is free to rotate inside of a sealed glass container.

By simply touching the outside of the container, people are able to make it spin on their own. The first example of such an object that would turn inside the glass is a spoked wheel:]

One of Pavlita's devices for demonstrating PK is shown in Figure 8. The usual way of charging the device with psychic energy is to touch the temple area of the head with the hand, then touch the device. The accumulated energy then causes the spoked wheel to revolve. Pavlita claims that with training some individuals can learn to make the wheel turn by visual concentration alone...

[Note: This author has successfully turned a 3x3-inch square of paper, folded into a pyramid shape and suspended on a mounted needle while under glass, without touching the object. Although it is much easier to do it without glass covering, it certainly can be done in those conditions if you have the patience. So we can vouch for the authenticity of such experiments.]

Now in the end of this section of the document there are speculations as to possible military applications of such abilities. The second to last sentence is, to us, most revealing of the simple truth:

...more significant is the fact that Soviet and Czech scientists are pursuing an interrelated, unified approach to determining the energy sources and interactions underlying PK and appear to be far ahead of their Western counterparts in this goal.

Clearly there is a great deal of information to absorb and to consider within this document. Many of us might not have been aware of the anomalies surrounding the phenomenon of psychokinesis, including the creation of measurable electromagnetic, electrostatic, magnetic or gravitational fields around target objects.

Even more importantly, the energetic field around the objects was showing the same rhythms as those within the person's body – such as heartbeat and respiration rate. Consequently, if a person is able to create all of the main "fields" that we observe on the macro level by consciousness, (excluding the atomic-level weak and strong nuclear forces,) then we should clearly put consciousness at a higher plateau than these other forces, as a unifying factor for all these forces.

In other words, if the fundamental forces of nature that our scientists have observed can all be created or harnessed by a force of consciousness, then ultimately they must all be connected in Oneness.

Furthermore, Kulagina's experiments with PK clearly demonstrate that the amount of love or sympathetic vibrations in the room had a noticeable effect on her results - skeptical, tense atmospheres created much more energetic stress on her than calm and relaxed, supportive situations.

## **2.9 ALL IS ONE**

Our ultimate contention is that all of the fundamental fields – gravity, electromagnetism, weak nuclear and strong nuclear force – must emanate directly from the aether, a unifying force of sympathetic vibrations that forms all of physical reality as we now see it. Consciousness is fundamentally interwoven with this process.

If the Unified Field is pure energy, and the energy must move to form all of physicality, then ultimately Consciousness is another form of aetheric movement. Once a person is properly trained, they can use their consciousness to create motion in the aether in any of its forms, including the commonly observed force fields. And as the Russian scientists have demonstrated, this is no longer speculation; this is experimental data.

In our next chapter we will venture into a discussion about how these concepts of aether and consciousness expand out into the cosmic context – where planetary energies are seen to have a structured effect on human consciousness, thus marking out the passage of time.

We will also review data that suggests that alternative planes of existence are indeed a tangible reality, and that the soul of the human being can exist in more than one plane at a time. At the end of the next chapter we will post a review of the contents of these two chapters combined.

## **3.1 LOVE IS VIBRATION**

Considering what we have just reviewed in the last chapter, we must advance another philosophical premise. If consciousness and love can manipulate matter, create all known energy fields and is ultimately a vibrational movement of aetheric energy, then:

The level of love, consciousness or intelligence in a given area is directly measured by the vibrational speed of aether in that area.

Hence, if the aetheric “fabric” of space and time has a given area where the vibrational speeds are faster, then a higher degree of intelligence and love is capable of existing in that area; simply put, there is more energy available in that area. This explains why Nina Kulagina’s telekinetic abilities “worked better in an atmosphere of friendly mutual trust and belief.” Furthermore,

All conscious processes are capable of moving much more quickly, and thereby exhibiting higher intelligence and love, where energy itself is moving much more quickly.

Clearly, studies such as the Maharishi effect show us that an experienced group of meditators were actually able to make a definite decrease in the amount of violent acts committed in a given city; ultimately, they made the aetheric energy vibrate more quickly in that area.

To put it in more familiar language, we could say that together, we constantly choose whether we will create harmony or fear in our own lives, and this directly affects all forms of life on Earth as a whole. And if you are one of the majority who believes that life must exist at least somewhere else besides the Earth, then you should know that our love affects all of the Universe in some way.

### 3.2 COSMIC ENERGIES AND CONSCIOUSNESS

Right away, it is easy for us to slip back into the habit of thinking of love as a particularly human trait, something indigenous to humanity that is not directly related to universal energy. Therefore, let us review our definition of “love” as simply indicating a higher degree of vibrational movement in the aetheric energy of a given area – no more, no less.

Kulagina couldn't perform her PK effects anywhere near as well when the researchers lowered the speed of vibrational movement in the aetheric energy that surrounded her, by thinking unloving thoughts.

In order to truly understand the “Cosmic Chess Game” as we have now seen it, we must think in very different ways than we are accustomed to. So again, everything we know as being “real” is created moment-by-moment from circulating currents of aetheric energy.

Thought is a circulating vibration of energy throughout the neurons in the brain. Loving thoughts strengthen life and health and unloving thoughts reduce health. But in the end, this “love” energy is simply a vibration of the aetheric energy that creates everything around us; and this by no means reduces its importance or holiness.

If love is simply a vibrational movement of aetheric energy, then there would have to be forces outside of group human consciousness that could modify these vibrations as well.

These forces must exist, because all of the Universe is in constant motion; all movements would ripple through the ‘sea’ of aetheric energy.

A quick mental exercise in visualization would easily show you that the entire Solar System must be immersed in a giant “pool” of aetheric energy in its own right, since it is quite convenient to view the aether as a fluidlike nonphysical energy substance.

Based on the new model of gravity, which will be explained much more precisely in future chapters, this energy would be constantly moving in and out of each planet, creating it moment by moment. Therefore, as each planet moved through this energy, it would create a rippling wave in the aether in much the same fashion as a motorboat disturbs the water behind it as it travels. And,

When a wave moves through a medium, you have a higher amount of vibrational movement in the wave than you do in the rest of the medium.

So indeed, the collective of humanity is not isolated on a lone planet, free from other influences. The aetheric / ET paradigm suggests that:

The Sun, planets and galaxy are conscious in their own right, since they are formed by conscious aether in vibrational motion, and they naturally create disturbances in the aether as they travel through space.

We must remember that this vibrational “wave” in space has greater motion, hence greater love and intelligence as we have defined it; and this affects humanity directly. The scientific evidence now available proves that this celestially-induced aetheric motion can far supersede the strength of “normal” human collective consciousness in terms of its capacity to modify our behaviors.

Furthermore, these planetary movements can actually be shown to have a direct effect on energetic behaviors in the quantum realm as well.

### 3.3 COSMIC CONSCIOUS ENERGIES VARY WITH TIME

The next point to see is that obviously, these planetary motions will change with time.

Since our planet is in motion along with all others, we will travel through the various planetary “ripples” in the aether of our Solar System in predictable, sequential moments of time.

Therefore, we can expect that a set sequence of energy vibrations will radiate through our bodies, our planet and all energy and matter therein, depending on the relative position of our own planet to the “waves” that have been created by the others.

An article in the summer 2000 issue of 21st Century Science and Technology Magazine entitled Russian Discovery Challenges Existence of “Absolute Time” debuted the ongoing body of rigorous work by Russian biophysicist Dr. Simon E. Shnoll to the Western world.

And to put it bluntly, his results prove the above statement: the planetary motions are creating a disturbance in the general medium of space that affects both living and nonliving processes on Earth directly.

[Link to article](#)

For the last thirty years, Shnoll has steadfastly been gathering data that demonstrated that many different biological, chemical and atomic processes, including the radioactive decay of many different materials, are somehow being directly influenced by celestial movements such as the day, month and the year.

At this point, we will just post a small excerpt:

Two years ago, nearly unnoticed in the West, the Russian biophysicist S.E. Shnoll published a paper in the prominent Russian physics journal *Uspekhi Fisicheskikh Nauk* summing up the results of more than three decades of investigations of anomalous statistical regularities in a wide range of physical, chemical, and biological processes, from radioactive decay to the rates of biochemical reactions.

The evidence points unambiguously to the existence of a previously unknown relationship between fluctuations in the rates of radioactive and other processes in the laboratory, and major astronomical cycles, including the day, month, and year.

The implication is, that many phenomena which until now have been regarded as purely statistical in character—such as the distribution of fluctuations in the momentary rates of radioactivity measured in a sample—are somehow controlled or at least strongly influenced by an astrophysical factor, which varies in time in the same way at all points on the Earth...

The histograms, made from more than two days from four successive 12-hour-long series of measurements, show another typical phenomenon discovered by Shnoll: The shapes of the histograms change over time (Figure 2).

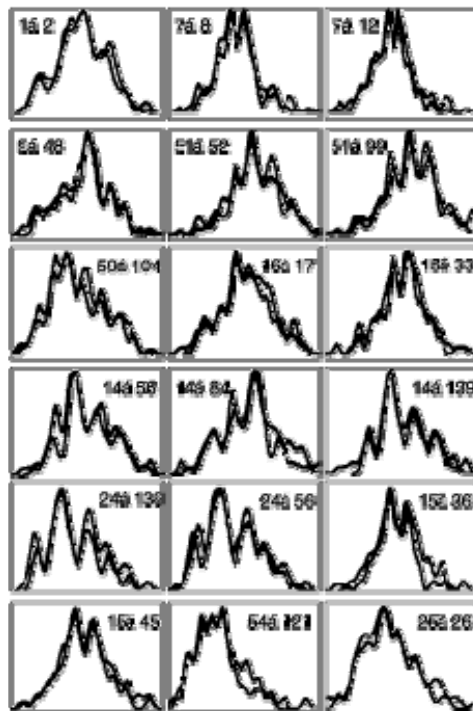

[Note: These histograms shouldn't be changing over time if radioactive decay is truly a random process, as quantum physicists believe. They should look like smooth, bell-shaped curves and should not have any of the bizarre spikes that we see.

Elsewhere Prof. Shnoll tells us that almost all scientists simply call this “noise in the data” and ignore it, since they have no reason to think otherwise.]



Most remarkably, the shapes of histograms for independent (and seemingly unrelated) measurements taken over the same time period, tend to be very similar.

For example, simultaneous measurement of the reaction rate of ascorbic acid, dichlorophenolindophenol (DCPIP), and beta activity of carbon-14 show histograms of very similar shape.

[Note: In other words, there is a similarity in the reaction rate of biological compounds, chemical compounds and radioactive decay, simply because the measurements were taken at the same moment in time. In the mainstream model, this shouldn't exist!

The structured waves in the histograms above are supposed to be simply “noise in the data.” We shouldn't be seeing identical “noise” in totally unrelated processes!

Somehow, all physical matter on the Earth is responding in the same way to external movements. If we see only “empty space” as existing between the planets then we have no possible way to demonstrate this.]

These and a large number of other experiments carried out by Shnoll and his collaborators over many years, point unambiguously to the existence of a universal factor influencing the shapes of histograms, and which varies in time.

Furthermore, the Russian researchers have discovered well-defined periods, over which similar histogram shapes tend to recur (Figure 3).

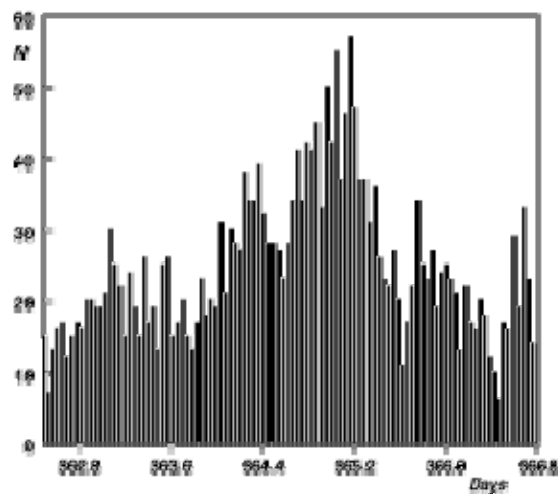

To do this, they devised a computer-based algorithm for measuring the relative degree of “closeness” or similarity of histogram shapes, and on this basis carried out a computer analysis of hundreds of histograms taken over a long period.

Examining the distribution of time intervals between “similar” histograms, they found strong peaks at 0 hours (that is, histograms made independently at the same time tend to be similar), at approximately 24 hours, at 27.28 days (probably corresponding to the synodic rotation of the Sun), and at three time intervals close to a year: 364.4, 365.2 and 366.6 days.

[Note: The “synodic” rotation of the Sun that they are associating this with is what occurs at its equator, which has been measured as being 26 days in length; so far this is their best guess as to what the 27.28-day period could be.]

More recent data, just reported to the author, indicate that the “24-hour” period is actually slightly shorter, and corresponds quite precisely to a sidereal day!

The latter would suggest, that at least one astronomical factor influencing histogram shape may originate outside the solar system, being associated with the orientation of the measuring station relative to the galaxy, and not only relative to the Sun.

[Note: The sidereal day relates to the Earth’s “precession of the equinoxes,” which we covered thoroughly in *The Shift of the Ages* and will do so again in this book. This precession has now been clearly shown to relate to our position in the Galaxy, since it is a much longer-term cycle than most others that we have observed.]

And so, if we are willing to receive the hard facts, the conventional ideas of subatomic physics are in big trouble. Dr. Shnoll is clearly telling us that the movements of the planets create extremely precise energetic disturbances in space and time that affect every single atom, molecule and energy process in the surrounding area.

If we look closely at the above histograms of these various processes, we can see that they have “spikes” where none are expected. Most scientists throw away this data automatically as being unimportant; only Prof. Shnoll, after more than 30 years of research, had the insight to compare the actual diagrams to each other and see if he could find connections.

He then saw that all biological, chemical and radioactive processes show the same minute energy changes in the histograms used to measure them at a given “point” in the time of Earth’s movement through the solar system and galaxy.

Shnoll’s work “points unambiguously to a “universal factor... which varies in time.” The aether model, as we have specified it above, explains exactly what this universal factor is. There must be a medium in free space that is

disturbed by celestial movements, and this same medium must also be responsible for creating the biological, chemical and atomic processes on a moment-by-moment basis.

### 3.4 STRUCTURED AETHER MOVEMENT IN THE STOCK MARKET

In the case of Shnoll, an unambiguous, body of research exists to show that simple correlations were able to be drawn between a “Universal Factor” that linked planetary movement with physical, chemical and biological processes.

These effects cannot be denied; the data has been gathered over a thirty-year period and has now been released to the world in a major scientific publication. From this research, one basic challenge was answered; planetary movement is creating an effect on the quantum processes of our physical world.

The implications of such a discovery are tremendous, and if you are just reading quickly through you might not stop and really think about how much this changes our view of the Universe. This certainly could be why free energy and “cold fusion” experiments have time-variable effects; they don’t always ‘work.’

However, if our model is correct, these planetary influences cannot simply stop with physical processes; they must affect human consciousness.

In order to determine how this could be possible, we would need a simple way to measure the collective status of human consciousness; a form of data that has been collected very steadily, very carefully and unambiguously, for long periods of time. That simple “measuring rod” can be found in the movement of financial markets.

The amount of data produced by such transactions each year is estimated to fill 24 CD-ROMs, which is a volume of information that most scientists would give anything to get their hands on if it were for their own studies.

Plus, anyone who works in the Stock Market will tell you that it all runs on love and fear. When people are happy and confident, it rises, and when people are depressed and fearful, it plummets; hence the term “Great Depression.”

The work of Bradley Cowan, introduced in our previous volume, shows us that:

*The movement of financial markets, and hence collective human behavior, can be precisely modeled, in advance, by calculating the geometric interaction of various planetary cycles.*

As we showed in the previous volume, this image from the “Cycle-Trader” website is a “composite” chart, summarizing all the different influences of the planets into one single graph. This graph is then compared to the actual market movements. Even though the movements were only halfway in progress when the graph was created, they continued to follow it precisely.

If you would like to read more about it, you can check this link: [Cycle-Trader](#).

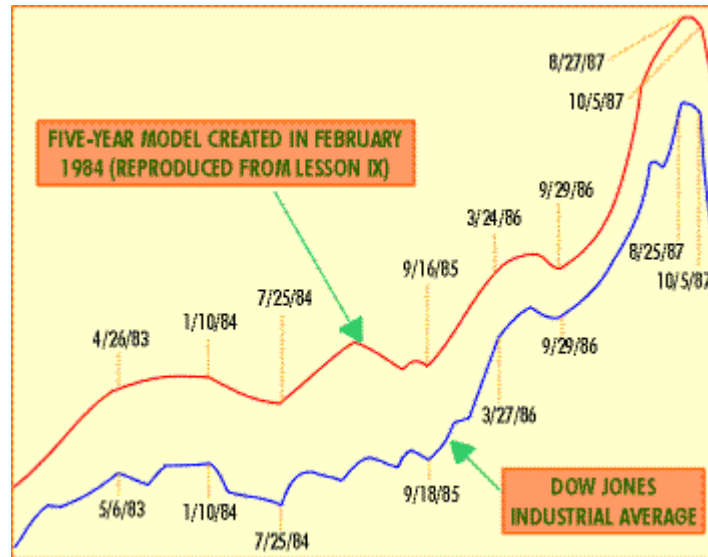

Some planetary cycles naturally increase the vibrational speed -- and therefore the intensity -- of aether surrounding the Earth, while others decrease it. By combining these cycles together, Cowan is able to form a very precise map of what the markets will do at any given time.

This planetary model, seen in the upper line of the graph, was created in February 1984, solely through understanding the geometric structures of planetary cycle interactions. The model indicated how the markets were expected to behave over the next five years, based on the observations already in existence. The lower line on the graph revealed how these interactions actually moved on the Dow Jones Industrial Average.

The skeptic will simply dismiss this out of hand, without bothering to check into it any further; and yet Cowan and other members of his group have continued to make very accurate predictions, one of which was posted in advance on the ascension2000.com website. We expected a worldwide low between Oct. 24th and Oct. 26th, 2000, and the low came precisely on Oct. 25th.

Furthermore, the escalating downturn of the NASDAQ at the time of this writing (March 2001) can be precisely modeled by a graph of the DOW from 1929, simply moved 71.5 years into the future and advanced on the time axis at double the speed of the original graph; this has also been published in one of our online articles.

So far, we are unaware of the titanic forces that shape and move our behavior in these ways, but that time may rapidly be coming to an end. Once we recognize what's going on, we may well be able to reassert our ability to make choices that will override these influences and "get off the merry-go-round."

On the cycle-trader website link above, Cowan analyzes each successive change in the market that is seen in this graph and how his model predicted it, including the giant crash in 1987. Part of the action of this graph is being created by the rotational action of simple three-dimensional geometric forms, created by vibrational disturbances from motion of the planets -- and in later chapters we will introduce the information that associates geometry and vibration directly together.

With this powerful knowledge at hand, a significant amount of the sport in making investments is eliminated, as the whims of human behavior are already known in advance.

### 3.5 ORDER IN CHAOS

Furthermore, mainstream "Chaos" and "Complexity" theory has stumbled over this peculiar space-time behavior as well, but they do not yet have a model to truly explain why it works.

In Chaos theory we see that even things as apparently random as weather patterns, stock market prices, the historical flooding of the Nile River, the presence of noise in telephone lines, the ebb and flow of animal populations and the arrhythmias of a diseased heart are harmonically organized in mysterious ways – and these same organizational principles are behind the formation of organic life and inorganic matter as well.

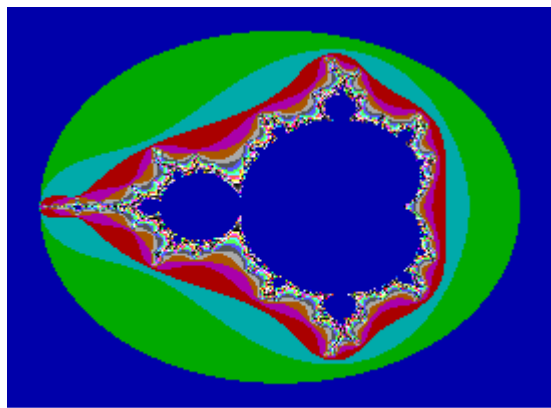

*The "Mandelbrot Set."*

Since most of science is quite reluctant to accept the existence of aetheric forces heretofore unseen in existing paradigms, the above findings of Shnoll, Cowan, Mandelbrot and others remain a mystery. However, with the aether models in this book we now have a workable energetic model that can explain all of these mysteries for us.

### 3.6 DON'T FORGET ASTROLOGY, LOCAL AND GALACTIC

And therefore, returning to Cowan's geometric structures in time and their effect on the stock market, if the very fundamental movement of aetheric energy that creates your body, mind and spirit moment by moment is rising and falling in predictable patterns as Prof. Shnoll has determined, then your behavior is likely to follow.

We have already established the premise that "love" and "intelligence" is the tendency for aetheric energy to adopt a higher state of vibrational movement. This outside effect on the energy of consciousness also demonstrates why many great minds in history have discovered that the science of astrology works with such incredible precision.

Indeed, the planetary motions in our Solar System affect the rise and fall of aetheric energies in very specific ways. And as the work of Prof. Shnoll has demonstrated,

*Our relative position in the Galaxy has an effect on biological, chemical and radioactive processes as well.*

### **3.7 PLANES OF EXISTENCE**

As we wrote in *The Shift of the Ages*, ancient religions and mythologies, modern “psychic readings,” crop formations, ET messages and now scientific investigation have all converged on the idea that our movement through the Galaxy is causing similar energetic effects on consciousness, only on a much more pronounced level.

Scientific data, once put in context, already shows us that these aetheric changes are far more dramatic than anything that we have seen in Cowan's stock market analyses or in Prof. Shnoll's chemical experiments. As we have said, an area of higher vibration is an area of greater love, harmony and intelligence.

Consequently, when the evidence is stacked up, we must be willing to consider that all of humanity is moving into a vibrational plane of greater love, harmony and intelligence. And this will literally amount to a “dimensional shift.”

In order for the concept of “planes of existence” to have any definitive meaning to the skeptic or scientist, we must present data from established institutions that supports the notion of their existence. Although more and more of the “common people” are increasingly comfortable with these concepts, the skeptic will simply ask, “What other planes of existence? Hogwash. There is no scientific evidence that there are other planes of existence, higher, lower or otherwise.”

To deny that other planes of reality exist is to stand in clear ignorance of commonly available scientific knowledge being done by credible Ph.D.'s in various fields.

#### **3.7.1 LUCID DREAMING**

For example, Dr. Stephen LaBerge has conducted dream research at Stamford University Sleep Center for many years, and he has come up with surprising conclusions, featured in his books *Lucid Dreaming* and *Exploring the World of Lucid Dreaming*. Lucid dreaming is defined as “the ability to be awake and aware in dreams.” As Dr. Robert E. Ornstein, author of *The Psychology of Consciousness*, comments,

Stephen LaBerge has proven scientifically that people can be fully conscious in their dreams while remaining asleep and dreaming at the same time.

Simply put, our current theories about how the brain functions would say that lucid dreaming is impossible; our dream state is “subconscious” because the brainwave activity cannot support normal waking consciousness as we now understand it.

At best, most psychology-based dream researchers would say that the dream state is “pseudo-conscious,” the result of the synapses firing haphazardly to transfer the most important information of the day into long-term memory.

If the dream state wasn't a “real” place that was somehow created outside of the brain, then it should be impossible for complete waking consciousness to exist there; all of our existing models of consciousness would fall apart.

And yet, Dr. LaBerge's research shows that:

In a lucid dream, a person maintains thinking, analyzing and reasoning properties, while interacting with an entire world of multisensory stimuli that is continually changing.

Furthermore,

As the participant moves through this multisensory world, rich symbolic imagery naturally takes place that will expose the most profound psychological issues that the person is facing in their life, and offer remarkably insightful solutions using the language of symbolism.

So now, we have a brain that is not exhibiting the normal signs of consciousness as science understands them; it is asleep, or "un – conscious." We have a brain that is supposedly creating a world of intelligent symbolic / metaphorical information that the participant usually will not even understand, but nevertheless provides valuable psycho-spiritual data to the Ego mind.

We also have a brain that is supposedly supporting normal conscious thought processes as it interacts with this intricate world. If our brains are truly capable of doing all this, then where do we find the neurological activity that demonstrates it? We don't.

And while we're there, let us also cite information from Lt. Col. Tom Bearden regarding certain cases of "hydrocephaly." This is a condition where a very high percentage of a person's brain is missing, and only water remains in its place.

One would expect that these people, if alive at all, would be totally brain-dead. Although you're not going to hear much about this in the scientific mainstream, there are fully functional hydrocephalics walking on the Earth right now.

One man even earned a degree in mathematics from Cambridge University, and MRI scans of his skull cavity showed that only a tiny stump of nerve tissue existed directly above his spinal cord at the base of the skull.

And all scientific researchers agree that each human being must physiologically go through several R.E.M. (rapid-eye movement) or dream states each night in order to stay alive; so our hydrocephalic mathematician would be included in that lot as well.

Somehow, the true process of consciousness in the human being is outside of the brain as we now know it; the brain may be one place for such consciousness to exist, but ultimately all consciousness is a movement of aether. Somehow, the water in the skull cavity gives this movement a chance to register its vibrations to the body in a recognizable way.

Therefore, even as these lucid dreaming events demonstrate effects in the physical body, they can be proven to exist outside of typical neurological functioning in the brain; some people can have fully "normal" lives with nothing but water in their skull cavity. (It is important to point out that not all hydrocephalics are this fortunate.)

Again, what all this ultimately tells us is that human beings are fundamentally multi-dimensional creatures, and there are indeed other “planes of existence” that we can move into without the use of the physical brain.

So again, what would we expect from a “higher plane of existence?” Remember that we said that as the vibrational motion of aetheric energy increases, love and intelligence increases as well. And indeed, the experience of a lucid dream can be so profound as to reveal an entirely undiscovered new plateau of consciousness – literally, a higher vibration, which many automatically feel to be a form of “heaven.”

For one who has never experienced this, the testimony of others is needed to explain it properly. Consider the following, from Dr. LaBerge’s first book:

The impact resulting from the emergence of lucidity is probably proportional to the clarity and completeness of the dreamer’s change of consciousness.

There are degrees of lucidity, and the common experience of awakening from a nightmare after realizing it was “only a dream” is typical of the lower ranges (or why escape from what is “only a dream”?), and is usually accompanied by no greater feeling than relative relief.

But the full-blown lucid dream, in which the dreamer stays in the dream for a period extended enough to allow the experience of wonder, can be associated with an electrifying sensation of rebirth and the discovery of a new world of experience.

First-time lucid dreamers are often overwhelmed by the realization that they have never before experienced their dreams with all their being, and now they are utterly awake in their sleep!

This is how one lucid dreamer described the expanded sense of aliveness brought by the lightning flash of lucidity: he felt himself possessed of a sense of freedom “as never before”; the dream was suffused with such vital animation that “the darkness itself seemed alive.”

At this point, a thought presented itself with such undeniable force that he was driven to declare: “*I have never been awake before.*”

Wilcock has personally used Dr. La Berge’s MILD (Mnemonic Induction of Lucid Dreaming) technique for the last eleven years, with ongoing success. In the lucid dream or out-of-body state, you can literally do anything, go anywhere, fly, pass through solid objects, levitate objects of any size, create anything your heart desires and get powerful spiritual questions answered immediately in a very direct format.

If you want to see yourself on the flight deck of a UFO, there you are – the possibilities are endless. The MILD technique is quite simple, once you discipline yourself enough to remember your dreams each morning.

Dr. La Berge demonstrates that anyone can learn to do this. By making a consistent effort to write down “what was just happening to you” every morning when you wake up, and remaining motionless upon awakening while you recall the data, you can get consistent results. Here is the four-part MILD technique:



1. During the early morning, when you awaken spontaneously from a dream, go over the dream several times until you have memorized it.
2. Then, while lying in bed and returning to sleep, say to yourself, "Next time I'm dreaming, I want to remember to recognize that I'm dreaming."
3. Visualize yourself as being back in the dream just rehearsed; only this time, see yourself realizing that you are, in fact, dreaming.
4. Repeat steps two and three until you feel your intention is clearly fixed or you fall asleep.

So, any reader or researcher who is willing to put in the effort can verify it for themselves. Far from a "random firing of synapses" in the brain, Dr. LaBerge's research suggests that the world of dreaming is far more "real" than we have given it credit for.

The next logical question from the skeptic might be, "Well, all this is fine and good. Anyone can say that they had a lucid dream, but they are just deluding themselves. There is no way to actually prove that someone is in the lucid dreaming state."

Wrong again. Dr. LaBerge proved that lucid dreaming is a genuine phenomenon, happening in real time with the physical world. In order to make these discoveries, it was necessary for him to devise a way for his "oneironauts," or dream voyagers, to signal to him that they were dreaming.

After pondering this idea for quite some time, he realized that the eyes are the most mobile part of the body during the dream state; hence the state is referred to as "rapid-eye movement." So, by training his oneironauts to simply move their eyes back-and-forth horizontally in their dreaming state when they had attained lucidity, they would form a movement in their physical body as well.

By simple observation, this repetitive horizontal movement would signal to Dr. LaBerge that they have attained the state of lucid dreaming. By using this signaling effect and other simpler procedures, he was able to make the following correlations:

Our studies at Stanford cover considerable ground, showing the relationship between physiological changes in lucid dreamers' bodies and a variety of actions carried out by their "dream" bodies within the dreams.

Our investigations addressed a range of relationships: between estimated dream time and actual time (the time interval that a person signaled with eye movements as being ten seconds in a dream was the same as when awake -- an average exact time of thirteen seconds;) between dream action -- including eye movements, speech, and breathing -- and corresponding muscle action;

between dreamed singing and counting, and relative activation of the left and right cerebral hemispheres of the brain (since counting and singing activate the opposite hemispheres accordingly;) and between dreamed sexual activity and changes in a variety of genital and nongenital physiological measures.

And so, the proof is now available that dreams are “really real” and really have an effect on the physical body, and yet they exist somewhere outside of normal brain function as we now understand it; we are in “both places at the same time.” Even if our consciousness travels elsewhere, our bodies are still working together with those other levels.

This is a far richer model than what mainstream science has conceded thus far, in many published studies. In the lucid dreaming state, there is an entirely new realm to explore with distinct properties all its own. The degree of richness and variety of this realm is arguably far more sophisticated than the brain could create on its own, and this brings us to our next point, which is very important:

*Others are capable of entering into the same out-of-body realms and independently reporting the same experiences upon awakening, without talking to the other participants.*

Wilcock discovered this for himself in a very dramatic way. While drifting off to sleep as a guest of his high-school friend Jude, he had a dreamlike experience of being chased by a menacing overweight person with long hair, an obvious symbolic representation of the parts of himself that he had not fully accepted and integrated at the time, stemming from younger years where he was indeed overweight and wore long hair.

As he ran, he had a gun in his belt and knew that he could use it to shoot his pursuer, and thereby save himself, but he was unwilling to stop the chase. Symbolically, the meaning of “shooting” this former self was the idea of allowing the personality traits and influences from that time of life to literally die out, so that they no longer would affect his thoughts and behaviors in the present.

The difficulty that he felt with the shooting was a representation of how hard it is to “let go” of old attitudes and behavior patterns, such as depression, lack of self-esteem, irresponsibility and desire for rebellion.

Then, as Wilcock continued in this experience, in the bed next to him Jude started tossing and turning.

*“Shoot him... Just shoot him. Two bullets,” Jude mumbled.*

Needless to say, Wilcock had a very hard time going back to sleep after this!

### **3.7.2 OBE'S AND THE MONROE INSTITUTE**

This parallel experience in higher “dreaming” realms of existence is a commonplace occurrence in the out-of-body research of Robert Monroe and the Monroe Institute, with numerous MD's and Ph.D.'s on board as staff and directors to vouch for its validity.

The Monroe technique involves stimulating the brain naturally through the use of opposing sound frequencies, where one ear hears a slightly different pitch than the other. The signal from each ear feeds into a different hemisphere of the brain. As the brain attempts to align the signals in the two hemispheres, this causes the synaptic impulses to enter into a “beat pattern”.

Since the signals are not quite perfectly aligned, the brain will never be able to synthesize them together permanently, but it will be able to do so in set periods of time, over and over again. Those periodic moments of “hemispheric synchronization” automatically move the brainwave state into a variety of rhythmic states such as alpha, beta and delta, which mimic the brainwave states of advanced yogis and meditators.

In the Monroe Institute’s Farsight Voyager course, groups of participants often report traveling to the same areas together and having the same experiences.

Arguably, the ultimate case of shared experience in the Farsight Voyager course can be found in Monroe’s book *Far Journeys*. It is a personal account from a female client, number 2312-CF, and we have shortened it considerably for the sake of brevity:

Then quite unexpectedly I was suddenly drawn by a powerful force to one room in particular – to one CHEC unit in particular. (Note: The CHEC units were where each participant was housed individually.)

It took me by total surprise, for the man in that unit was someone I didn’t know very well. In fact, he was the only one at the workshop I had never really had a chance to talk to. He was a young, good-looking psychologist, yet for some reason we seemed to be purposefully avoiding each other.

All at once I had an all-knowing, as I seemed to float over him, that his vibrations were my vibrations. I had an overwhelming desire to meld, to feel a part of him – to become one...

I gave to him both my body and soul until there was this tremendous energy surge that rocked and exploded in us. It was an experience that is beyond words, for love, total and absolute, surrounded us more strongly than can be earthly experienced or imagined...

We talked in this state and I came to realize this experience could only have happened at the end of the workshop as it did, for each of us would have been distracted had we ‘met’ earlier on – perhaps hampering other growth experiences that week...

I truly experienced everything I asked for and more, and when I came down to the meeting room after the tape there was an unusual heightened energy where people seemed to be flying. I saw ‘him’ as I came down the stairs to join the group and he looked at me excitedly, ecstatically, as if something totally incredible had happened to him.

I hadn’t said a word yet, as he quietly repeated a number of times, ‘*Thank you. Thank you.*’ I felt elated – I had made contact. We compared our individual experiences, making sure each of us was not coloring the other’s story.

It didn’t matter – our stories fit like puzzle pieces, matching perfectly and interlocking. We both had also had the use of all our senses – the strongest being touch.

After this experience we were later reunited to share others together. We’ve been with each other for the past two years now – growing and loving together.

In the book *Cosmic Voyage*, Dr. Courtney Brown reports an experience in the Farsight Voyager course where he saw a group of people, all holding hands, enter into a tunnel of energy together. Upon awakening, he realized that this is exactly what they had planned to do together before going in, and they had all experienced the same phenomenon.

Furthermore, we remember that the Monroe tapes are used as a preliminary means of training for military remote viewers, then enabling them to travel out-of-body to distant locations and make accurate observations of what they see there.

So, it should be obvious to us that this outer realm of consciousness is a genuine plane of existence and not simply a “mass hallucination,” thus explaining how the group of people in Dr. Brown’s experience could all end up sharing the same experience.

In the course of Monroe’s three books, he outlines his own exploration of the various energy realms surrounding the Earth and beyond, including the intelligences that he interacted with along the way.

In considering the information from Monroe, Dr. LaBerge and many others, we must accustom ourselves to the realization that there are indeed higher planes of existence, and that we can travel in them as easily as we travel in this one, once we have gone through the proper training.

Ultimately, if each “dimensional” level is simply a different frequency of one vibrating aether, then each “dimension” above our own must be filled with life which is far more loving, harmonious and intelligent than the level beneath it. This information is repeated in almost every form of mystical teaching in existence.

### **3.8 RECAP: THE BEAUTY OF THE AETHERIC MODEL**

As we have already suggested, a revised version of the aetheric model will resolve many current paradoxes, and must ultimately replace the ideas that are now being used. In the last two chapters we have had a discussion about the concept of an ‘aether’ with the focus on a philosophy of consciousness that helps us explain the results from a broad number of scientific findings. We have reviewed the following key points:

- That zero-point energy or “aether” genuinely exists;
- That since consciousness exists, it must be a function of the Unified Field;
- That love is the tendency for entities within the Unified Field, whether human, “particle” or otherwise, to increasingly radiate Harmonic Unity, through vibrational motion;
- That love is a radiating, strengthening, unifying force, vibrationally moving towards the central point of Oneness; whereas hate, or the absence of love, is an absorbing, dis-integrating, weakening force, absorbing energy away from the central point of Oneness and compartmentalizing it;
- That the Backster Effect has demonstrated these concepts of aetheric vibration with plants, bacteria, yogurt, Planaria worms, human cells and more;
- That these principles can be demonstrated by the connection between anger and cancer;

- That the Maharishi Effect, levitation and psychokinesis demonstrate even greater movements of aetheric energy by consciousness;
- That Nina Kulagina was able to create all the basic electromagnetic forces by the sheer focus of consciousness, ideally in a loving environment;
- That energy measurements taken around objects being telekinetically moved by Alla Vinogradova detected field pulsations which were synchronous with her respiration rate, heartbeat, and brain alpha rhythm pattern;
- That the level of love, consciousness or intelligence in a given area is directly measured by the vibrational speed of aether in that area;
- That planetary and galactic interactions can cause changes in the vibration of aetheric energy;
- That we can expect that a set sequence of energy vibrations will radiate through our bodies, our planet and all energy and matter therein, depending on the relative position of our own planet to the “waves” that have been created by the others;
- That the structured histograms to chart different biological and atomic processes, including the radioactive decay of many different materials, are directly influenced by celestial movements such as the day, month and the year (Shnoll, 2000);
- That movement of financial markets, and hence collective human behavior, can be precisely modeled in advance by calculating the geometric interaction of various planetary cycles (Cowan, 2000);
- That our relative position in the Galaxy has an effect on biological, chemical and radioactive processes as well (Shnoll, 2000);
- That to deny that other planes of reality exist is to stand in clear ignorance of commonly available scientific knowledge, such as Dr. La Berge’s data on lucid dreaming and The Monroe Institute’s technology for inducing OBEs;
- That others are capable of entering into the same out-of-body realms and independently reporting the same experiences upon awakening;
- That ultimately, if each “dimensional” level is simply a different frequency of one vibrating aether, then each “dimension” above our own must be filled with life which is far more loving, harmonious and intelligent than the level beneath it.

Considering all these factors, we have a substantial new paradigm that can explain many various anomalies related to consciousness. Ultimately, we are given a very strong foundation upon which to build the central premise of this book: that we are moving through structured vibrations in the Galaxy that will create a significant enough change in aetheric density to cause a “dimensional shift” into a plane of existence that is currently higher than our own.

To some, this might seem like the end; but in fact, it is the beginning. Now that we have carefully established a conceptual framework that ties in these concepts to consciousness, we are ready to present the incontrovertible scientific evidence that the aether exists by showing how it can be harnessed with technology and understood scientifically, producing effects such as free energy and anti-gravity.

As we go through these chapters, we will gradually reveal the signatures of vibration, either luminous, acoustic or geometric, in these workings. We will then explore the modern scientific data regarding “higher dimensions” and again reveal the numerous indications that such a harmonic or vibrational process is at work.

Then, Part One of the book will conclude with excerpts from alleged extraterrestrial beings that will give us an unusually valuable insight into how these processes are most likely functioning.

If you find yourself unable to follow the discussions regarding the new energy technologies and anti-gravity, don't give up! By reading the “Recap” sections at the end of each chapter you can avail yourself of the main points that are being made and get through the sections that might not interest you.

We recommend that if you do decide to do this, you should fully pick up the thread again in Chapter Seven.

## CHAPTER 04: HARNESSING THE CONSCIOUS AETHER WITH GRAVITY AND INERTIA

[Tweet](#)

### 4.1 A NEW MODEL OF GRAVITY

We have clearly examined the evidence that suggests that what we are dealing with is a universal, time-varying energy source that unifies all areas of “empty space” together as a Oneness. The work of Prof. Shnoll gives us incontrovertible evidence that a whole hidden dimension exists in the quantum field that we are completely unaware of, which shows that “all motion is relative” in ways that we had never before imagined.

The studies with Nina Kulagina and Alla Vinogradova prove that human consciousness can directly create and / or affect all the known energy fields of science. Our thoughts will move through all of our cells even if they have been removed from our body and placed at a distance.

For all of these phenomena to occur, there must be an aetheric energy, and this energy must stream into all physical matter in order to sustain its existence. So bearing that in mind, what exactly is gravity in this new model? How does it relate to the philosophy of Oneness and the “big picture?”

Our fundamental premise for this book is that as human beings, we only have an illusion of being separate; in reality, there is only one Supreme Being, one Consciousness, and we are very much like cells in this body – a body that is evolving. A number of different sources give us a metaphysical meaning for gravity, the most common being that gravity represents the tendency for all parts of the Creation to seek Oneness, to seek reunion with the Center.

Furthermore, in the work of Dr. Walter Russell, a truly multi-talented artist, scientist, architect and musician, we have an enhancement on this concept for gravity. In the Russellian model, gravity again is the tendency for all objects in the Universe to seek the center, but he then goes on to say that once reaching that center, new matter and energy is radiated outward.

As we progress, we will see definite experimental and observational evidence that this must be true; as one example that we will cover in later chapters, this could very well explain the observation of the phenomenon known as “sonoluminescence.” In this chapter, our focus will be on getting a true understanding of gravity and the closely related force of inertia, and also show how these forces can be harnessed to create anti-gravity propulsion technologies.

So begin by asking yourself this: if you have an object in an area with no air and zero gravity, do you expect to encounter resistance when you try to move the object through space? It's empty space, right? There shouldn't be any resistance in empty “vacuum” space, should there be?

#### **4.2 NEWTON: PIONEER OF GRAVITY AND INERTIA**

The answer to this question as well as our understanding of gravity came about from the work of Isaac Newton. Perhaps the ultimate cliché in all of science is the image of Newton sitting under a tree and discovering gravity when an apple fell down and hit him on the head.

From this initial inspiration, Newton composed a series of laws including gravitation and the “law of inertia,” which everyone remembers from their science classes as, “An object at rest tends to stay at rest, and an object in motion tends to stay in motion.” And that means that even in an airless vacuum without gravity, you will encounter a force that will cause you to have difficulty moving something through space!

So what exactly is that object moving through? In the conventional models it is simply a “force” and nothing more is discussed. Here, we will suggest that this force is caused by the energy of the universe. Therefore, if we consider the spiritual perspective of our living in One Ultimate Being, then we can see how this shows us that no matter where we go in the Universe, we are always moving through the energy “body” of that Being, drawing the energy of space along with us.

### 4.3 CENTRIFUGAL AND CENTRIPETAL FORCE

Specifically, inertia is the force that you see being used in the science fiction movies when a space station is constantly rotating to create artificial gravity. Thanks to the power of inertia, the rotation of any object will cause centrifugal force to form, which is what allows you to spin a bucket of water around your head in circles and have it never spill out.

Centrifugal force will actively push away from the center of any object that is rotated, whereas centripetal force is created when the force presses towards the center of a given object or area. The centripetal force is most easily seen at the center of a whirlpool, where all force is pushing towards the center.

### 4.4 PRINCIPLE OF EQUIVALENCE

So, we all know that gravity is very strong, as there's nothing we can do to resist it, but inertia doesn't seem as powerful; we hardly ever notice it or pay attention to its existence. However, this is not the way it works! Anyone who studies this information will know that the basic equations for gravity and inertia work in exactly the same way.

This means that if you have a given object, both gravity and inertia exert the same amount of force on the objects. Einstein discovered this and referred to it as the "Principle of Equivalence." What that means to us is:

**Somehow, the forces of gravity and inertia are married together, as though they were one and the same.**

Although science should clearly have suspected that a new universal law was hiding in the Equivalence Principle, no one in the mainstream truly has a good explanation for it yet. However, before we look into that part of the puzzle, we must take a better look at the evolution of the theory of how gravity works, since the concepts have become more complex since Newton.

Even though gravity has been radically reworked in relativity theory, the only change in the law of inertia since Newton is the Equivalence Principle, which simply says that "Gravity and inertia act the same," without ever explaining why.

### 4.5 EINSTEIN'S GEOMETRIC MODEL OF GRAVITY

The scientific community essentially remained content with Newtonian physics right up until the early 20th century, when Einstein created a radical new design for gravity. By postulating that all the universe is ultimately made of energy, not particles, he also created the rather bizarre-sounding idea that space and time are somehow fused together into a "fabric."



On the face of it, this seems completely ridiculous to the average person, since we don't think of time as a tangible thing; it is simply a measurement, and depending on your mood, your subjective perception of time could be very different.

When you're in love with someone, the clock could go "a mile a minute," but when you've got five minutes left at work on a Friday and you're watching the clock with anticipation, a minute can seem to take a lot longer – even the music on the radio could seem to get slower and more monotonous.

So how does time, something that to the human mind seems nothing more than a subjective perception of measurement, become a tangible "thing" that creates a fabric with space? We normally think of as simply being empty nothingness, certainly not part of a "fabric" that is married with time. It certainly isn't easy to think about, and that hasn't won Einstein a lot of friends in the arena of philosophy.

However, most of the physics community agrees that the universe must work in this way; neither space nor time is "real" as a separate entity, but instead they move and flow together. Even more importantly, a majority of aetheric researchers will quickly and gleefully point out on their websites that Einstein later admitted that the existence of an "aether" was not only possible, it was a requirement for this theory of General Relativity to be correct.

Obviously this is not a "popular" statement and most scientists will try to deny that he said it or make other types of excuses about it; remember that their favorite theories are at stake, and they will seemingly spare no expense to discredit the opposition.

#### **4.5.1 CURVED SPACE**

Now how does Einstein's space-time model equate with gravity, you ask? Einstein said that this space-time fabric curves inward around a planetary body, thus forcing any traveling object or energy force, including light, to be attracted by that body. The way that this is explained is generally to see this "fabric" as if it were a flat sheet of rubber that has been stretched out between four tacks.

A mass such as a planet would be visualized on a much smaller scale as a marble that has been placed onto the sheet of rubber. The weight of the marble would cause the rubber to dip down into a funnel shape, and the more mass that the marble has, the deeper the funnel would be. Other objects of smaller mass would roll down into the funnel in the presence of the larger object.

By giving us this model, Einstein felt content with having come up with a solely geometric design for gravity. No longer did we need to hypothesize a "gravity force," if the simple geometric structure of the space-time fabric itself, which he believed was simply a form of energy, caused these events to happen.

Simply traveling through space causes you to naturally move towards the object; the actual space around the object is, as he put it, "curved."

Although this is an excellent mathematical model that has been scientifically proven, up until now there was no clear-cut way to visualize it. Several problems immediately come to mind. First of all, we are puzzled by the idea of space as having substance, since "space" by its very definition is "empty."

However, in the aetheric model we see that Einstein's bizarre idea of a "fabric" in space now has a clear identity -- the ZPE / aetheric energy. As we said, in later years Einstein himself admitted that the idea of an aether was indeed required for this "space fabric" to exist, even though he wouldn't be quick to call it that due to the scornful opinions of the mainstream scientific community.

The second significant problem in visualizing Einstein's gravity model is that any curvature of space-time would need to surround a spherical object in three dimensions, which would ultimately form a larger spherical field of energy that was "curving" into the object.

In reality, the word "flowing" is far more precise than "curving," since we will suggest that this gravitational energy is constantly flowing into that planet! The typical "curved space" diagram is obviously incorrect because it tries to show this curvature as a flat sheet instead of modeling it in three dimensions.

#### **4.5.2 GRAVITATIONAL LENSING**

Even though the idea of spacetime being "flat" cannot be correct, the core idea of objects distorting the space around them is still a good one. Astronomers are quick to point out that there have been definite observations of "lensing" effects around stars, so that when one star passes behind another star, the gravity of the star in front can actually cause the light from the star behind to flow around it and become visible.

And obviously, this is called "lensing" because it appears as though the gravity of the object in front is acting just like a lens that reflects light. This surprising observation has been noted and photographed many times, and in some cases the light from the reflected star actually emerges in a semi-halo around the star in front, creating as many as four different images of the star behind, spaced symmetrically around the star in front.

This is about as much proof as any good scientist needs, and yet there is still a given segment of the alternative science crew that tries to dismiss these observations and completely disagrees with Einstein's new model of gravity.

By looking at the phenomenon of lensing, we can see that there is good reason to have faith in the basic concept that mass causes a distortion of the space around it. In the aether models, this has a much deeper meaning than in conventional thought.

Remember that at the beginning of this chapter, we suggested that gravity is not a "sucking" action coming from any given object, but rather it is the principle by which all matter in the Universe seeks the Center, or Oneness.

The basic philosophy states that the entire Universe is one being that is constantly evolving, and gravity is another way in which that being is growing; it is constantly striving to reconnect, to gather to Center, to strive once more towards Oneness. Though some people might feel this is wishy-washy and overly religious-sounding, the Law of One series illustrates this as a good metaphor of how a fundamentally conscious "ultimate being" manifests its own desire for Unity.

#### **4.6 ZERO-POINT ENERGY: THE FLOW OF MATTER**

As we said in Chapter Two, Dr. Hal Puthoff suggested that all parts of an atom would need to draw off of “zero-point energy” in order to sustain the atom’s existence. And since all objects in our Universe are made of atoms and molecules, then:

**All objects in our Universe, regardless of their size, are consistently drawing in aetheric energy to sustain their existence.**

**Without this ongoing influx of energy to support themselves, they would shed heat and dissolve back into aether.**

So what happens when you have objects of different sizes?

The larger an object is, the more aether will stream into it to sustain its existence.

This creates a force on other objects, since aether is streaming into them as well.

So, the aether could be thought of philosophically as the energetic “blood” of the Universal Being. Planets, stars and galaxies could be thought of as organs in its body, and they are constantly being refreshed by new life-force on a moment-to-moment basis.

This aetheric force, flowing in and out, is the father and mother energy of all matter, the very essence of life itself. This movement can be referred to in spiritual literature, both ancient and modern, as the “breath of life,” the “breath of the Divine” or the “breath of the compassionate.”

Later in this book, we will find out that observational evidence, gathered from the South Pole during the 24-hour days of sunlight at winter solstice, has proven that the surface of the Sun is continually heaving in and out in set rhythmic patterns, just as this model suggests!

Neither the Newtonian nor the Einsteinian models of gravity would be able to account for this un-anticipated movement, which intuitively makes the Sun feel much more like a living, breathing form of consciousness in its own right.

#### **4.7 CELESTIAL MASS AS AN “AETHER SINK”**

So, based on the concept that we have set forth, any object of matter in the Universe, such as the Earth, becomes akin to an “aether sink,” where the energy of the aether is constantly flowing into it from all directions equally.

Gravity, far from being a force of attraction, is actually created by the pressure of the “aether wind” as it continues to flow into the Earth from all directions moment by moment, pushing down or “curving in” all objects equally from the space around it.

Obviously, this is not the model of gravity that will be taught in modern universities, but it nevertheless fits better with the overall picture. We remember that the gravity equations do not specify which direction the force needs to be coming from; they work just the same if gravity is a movement of force towards the center of an object as they do if it is a ‘sucking’ force that reaches from the inside of an object outwards.

Thus, there is no evidence within Newton's laws that a skeptic can use to disprove this idea; it is simply a different interpretation than the one that is currently popular.

So, the Earth is a very large body, and therefore a very large amount of aether must flow into it moment by moment to sustain its existence. And since all matter is made of aether, a smaller object will invariably be caught up in the energy that streams into a larger object. If you were to accidentally fall into a raging river, the mass of your body would be little match for the much larger mass of water that you were now moving with.

If we apply this analogy of a powerful river into an aetheric model in space, we have an easy method of actually visualizing this aetheric energy flow. When we view gravity in this fashion, we are all like mosquitoes that get stuck on a screen door as the air blows through it; the ground halts our downward motion, while the aether slips through the earth's surface and continues to flow directly into the center, recreating every atom every moment.

And in Richard Pasichnyk's book *The Vital Vastness*, he reports on experiments that have proven that once you drill more than 2700 kilometers below the Earth's surface, a threshold is reached where the force of Earth's gravity suddenly begins decreasing rapidly... and by the time you get to the center it's theorized that there would be no gravitational force at all.

This is due to the fact that after the force of gravity rushes into the center, a part of it rushes back out of the center and thus counteracts the force of gravity. The depth of 2700 kilometers is the point where this outward movement is neutralized. In deep mines and boreholes, the strength of gravity is measurably different.

#### **4.8 GRAVITATIONAL ACCELERATION "CONSTANT" EXPLAINED**

Another "mystery" of gravity is that all objects fall at exactly the same rate, accelerating at either ten meters per second squared or thirty-two feet per second squared, depending on whether you use metric or English measuring systems. This is another scientific fact that is easily overlooked as being unimportant.

Most people will get caught at least once by the question, "Which weighs more, a pound of lead or a pound of feathers?" Former NASA consultant Richard C. Hoagland designed an experiment that was performed by the Apollo astronauts on the Moon, where a feather and a stone were dropped at the same time. Since there was no atmosphere to disturb the falling movement of the feather, they both traveled to the ground at exactly the same speed, just as the model had predicted.

At first, it might not seem that this is possible, since this concept forces us to admit that the mass of an object has no bearing on how fast it falls to the Earth. However, the new aether theory explains that the size of the object will not change its gravitational acceleration speed because the effect is being caused by the flux (or flow) of aether instreaming into the earth, not the weight of the object itself.

In other words, the speed of Gravity is only the speed of the flow of aether, and this has nothing to do with the size of the falling object, since all instreaming Earth energy will travel at the same speed. If we think back to our analogy of a raging river, two floating objects will travel on the surface of that river at the same speed, even though they are of different sizes.

The mass of the river is so much greater than the mass of the objects that the objects' masses have no effect on how fast they travel.

#### 4.9 OBJECTS CAN ABSORB OR RADIATE ENERGY AND CHANGE THEIR MASS

Another one of Einstein's most confusing postulates is that mass will continue to increase more and more as you approach the speed of light. Again, most people have heard of this concept since it is frequently used to "debunk" the idea that UFOs could really exist; in Einstein's model they would become infinitely massive as they approached the speed of light.

Although we will have a lot more to say about this issue in future chapters when we discuss the true meaning of the speed of light, for now we will just focus on the core concept, which is the idea that when an object moves more quickly through space, its mass increases. Conventionally, our scientists don't understand how or why this is occurring, but in the aetheric model it is plainly obvious.

When we move an object through "space," we are actually moving it through the aether. And that aether is a fluidlike substance that actually creates the object moment-by-moment. Therefore, if we see a given object as being like a dry sponge, then when we move that object through the "river" of aether, it will absorb more energy and thus increase its mass.

Now in the Einsteinian model, this is usually only seen as a one-way system: an object moves faster, its mass increases, and then you must deal with the consequences of a larger mass. This doesn't necessarily mean that the size of the object would increase, just the density of it.

However, if an object's mass can expand this way in Einstein's model by moving it faster, then would it also deflate its mass as it slows back down, like a balloon releasing the extra air that was once put into it? No scientist has proven or disproven that this would be true, but it poses an interesting question; if the aether model is indeed correct, then:

**An object's mass is a measurement that is capable of changing, depending on how it moves through the aether.**

This might not seem possible at first, but it can be visualized easily with the idea that the atoms and molecules are composed of electromagnetic fields that could absorb and release the fluid "pressure" of aether energy. In a natural state of rest, any object would automatically reach a balance between the pressure of energy inside of itself and the pressure of energy on the outside, as the energy would be continually flowing in and out at an even speed.

However, if some of the energy pressure was radiated away from the inside of the object, then during that time it would weigh less. We will explain how to make the energy radiate away like this in just a moment. For now, we also need to see that once we did this, a pressure imbalance would be created in the object similar to a vacuum.

As we know in the case of our atmosphere, once a vacuum is created in the air, the surrounding air pressure will cause new air to immediately rush back in. This is easily seen in the case of a thunderstorm.

First, a bolt of lightning causes an area of the atmosphere to be instantly vaporized, and this forms a vacuum. Then, the surrounding air will immediately rush into that vacuum, and we hear a clap of thunder as the waves of air crash into each other.

So, in the case of an object radiating away its energy pressure and forming an “aether vacuum” inside of itself, we know that the only way we could keep the anti-gravity effect working would be if the object was being forced to continually radiate away its energy on a constant basis. Otherwise, it would immediately fill its own “energy vacuum” with new energy and its weight would return to normal.

So how, then, do we get an object to radiate away some of the pressure of energy inside of itself?

**We rotate the object.**

#### **4.10 ROTATION AND CENTRIFUGAL FORCE**

As soon as we rotate the object, centrifugal force kicks in – the same force that would allow us to spin pails of water in circles around our heads without losing any water, if we did it fast enough. And as we are about to see with the DePalma Spinning Ball Experiment and others in the next chapter, many scientists have accurately measured slight decreases in the mass of an object when it is rotating.

Normally, since this effect is so small, it is only interpreted as an error in the data if it is even noticed at all. So, once again,

**Centrifugal force causes energy (mass) to fly away from the center, through rotation.**

Hence, if you only move an object in one direction through the aether, then like a dry sponge it will soak up more energy into itself. But if you rotate the object, centrifugal force causes the energy in the object to spray outwards.

If you’ve ever tried to use a blender or a coffee grinder without putting the lid on top, then you know that when those blades start spinning, whatever you’ve put inside that machine will very quickly be all over you, the wall and everything else in the room! This is the power of centrifugal force to cause any type of substance, either matter or energy, to radiate away from its center.

#### **4.11 INERTIA AND ANTI-GRAVITY**

So, how does this concept relate to anti-gravity? First, we must remember what our new definition of gravity really is. All measurements that we could ever make on Earth are occurring within this ‘river’ of aether, the very breath and lifeblood of Mother Earth.

No matter where our anti-gravity laboratory is located on this planet, the aether in and around it will not “hold still” for us – it will continually be moving downwards. The gravitational mass of an object is simply caused by the aether that “blows” it down towards the center of the Earth.

So, the basic concept is that if you can rotate an object at a high enough number of revolutions per minute, you should be able to cause it to radiate away some of the aether force that would normally be pushing it down. By radiating the downward pressure of gravity out to the sides, its weight, or mass, could lower.

Remember that if the earth has a constant stream of aether flowing into it, so does all other matter to a lesser degree. Rotation simply radiates the energy streaming into an object away from its typical downward gravitational motion. (Later in the book we will see that very precise sound vibrations can cause an object to vibrate violently and radiate energy away from itself as well, thus lowering its mass in a similar fashion.)

#### 4.11.1 DEPALMA'S SPINNING BALL DROP EXPERIMENT

Again, to use a metaphor that involves flowing water, this principle of defying gravity is just as simple as taking a water hose that is pointing downwards and bending it so that the water flows out to the side instead.

"Sideways" is not normally considered to be a gravitational motion, but it clearly does have a force, like when you are riding on a rollercoaster and feel pressure against your chest. This "sideways" force is inertia! Dr. Bruce DePalma, a non-conforming MIT graduate, demonstrated this principle with an extremely simple experiment.

First, he would release two balls from two catapults side-by-side at an equal angle, and have the catapults put an equal amount of force on each ball. The only difference would be that one ball would be spinning at the terrific speed of 27,000 RPM, and the other ball wouldn't be spinning at all.

In a complete vacuum, he would observe the trajectories of the two balls and see whether anything changed; their height, their angle, their speed of travel. And in so doing, DePalma discovered the impossible:

In defiance of all known physical laws, **the spinning ball actually traveled higher, fell faster and moved farther than its non-spinning counterpart.**

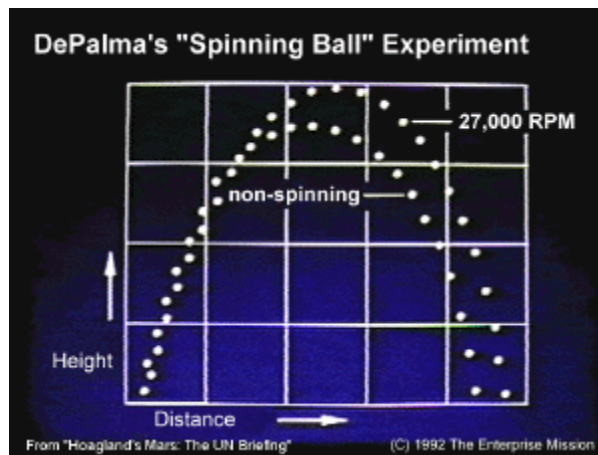

And as a side note, since skeptics are quick to ascribe all this to a principle caused by the atmosphere, we are reminded that it works just as well in a vacuum. The only choice that would remain is to attack the experiment itself, but as we go along we shall see that others have replicated this effect in many ways.

#### 4.12 INERTIA IS AETHERIC FORCE

And so, we can see that aether exerts force upon matter, such as in the case of gravity, and this force can actually be tinkered with. Therefore, it should be no surprise that Dr. Hal Puthoff and others have made the radical suggestion that the existence of aether or zero-point energy in space is the real reason for why inertia exists.

In an article published in the scientific journal MERCURY by B. Haisch and A. Rueda that discusses Dr. Puthoff's research, we see the following:

“...inertia is an electromagnetic force that switches on whenever an object accelerates through space... In our theory, inertia does depend on... an electromagnetic field (of aether) that pervades the cosmos.”

#### 4.13 FREE ENERGY AND MORE

As we shall see, this new information is vital to overcoming gravity and harnessing this "energy of the vacuum" to provide limitless free energy without cost. And time and time again, the efforts of those such as Nicola Tesla have provided this fruit, and it has been vigorously stamped out by the elite, who simply ask:

*"And where will the meters be on each house when we hook up this new energy supply?"*

When they find out that there is no profit margin in a limitless energy system, they see their wealth flash before their eyes and the researcher is silenced or even killed, as is most likely the case with Dr. Bruce DePalma, who died young and unexpectedly in 1998.

Tesla's career was completely ruined by JP Morgan in the latter years of his life and his work classified, while Edison took all the credit and remuneration for Tesla's innovations such as alternating current, which powers every electric outlet in the home.

And so, operational gravity-defying craft such as the Searl Levity Disc and free energy machines such as DePalma's N-Machine have already been built on these principles, as we shall see. As we described above with DePalma's Spinning Ball Drop experiment, perhaps the most useful relationship between gravity and aether is seen in rotation.

In the next chapter we will see a new concept of magnetism that gives us yet another way to harness the aether flow directly. Magnetism and electricity are very close cousins, enough so that they are defined by modern physics as being the same field -- i.e. electro-magnetism.

When we combine magnetism with rotation, such as by magnetizing a gyroscope and hooking it up to draw electric current from it as DePalma has done, you can create anti-gravity and free energy at the same time! The generation of "free" electricity from this one-piece "rotating magnet" concept was discovered by Michael Faraday all the way back on Dec. 26, 1831, even though most physicists would deem it impossible.

#### 4.14 RECAP



**4.1** Gravity is the tendency for all energy in the Universe to move towards the Center. Once reaching this center point, energy is re-radiated away from the center as light, heat and matter.

**4.2** Even in an airless vacuum without gravity, you will encounter a force that will cause you to have difficulty moving something through space. This is known as “inertia.”

**4.3** Centrifugal force will actively push away from the center of any object that is rotated.

**4.4** Gravity and inertia obey the Principle of Equivalence; they both exert the exact same degree of force on matter.

**4.5** Einstein modeled gravity as a function of geometry.

**4.5.1** Einstein saw the space-time fabric as curving. However, it is more convenient to see this geometry as a three-dimensional flow of energy streaming into the object.

**4.5.2** The “curvature” of space around a celestial object causes “gravitational lensing” to occur, where the light from a star behind it will curve around and become visible.

**4.6** All objects in our Universe, regardless of their size, are consistently drawing in aetheric energy to sustain their existence. Without this ongoing influx of energy to support themselves, they would shed heat and dissolve back into aether. The larger an object is, the more aether will stream into it to sustain its existence. This creates a force on other objects, since aether is streaming into them as well. The “breathing” movement of the Sun displays this flow of energy in action.

**4.7** The equations for gravity do not specify which direction the energy must be moving in. The idea that energy is moving down into the Earth as gravity and then radiating away from the core is supported by the finding that weight rapidly begins decreasing once we drill more than 2,700 kilometers beneath the Earth’s surface.

**4.8** All objects move at the same speed under the influence of gravity because they are “caught up” in the much more massive “river” of energy that is flowing into the Earth every moment.

**4.9** Einstein proved that when an object moves more quickly through space, its mass increases. This is actually an increase of “pressure” of aether inside the object. Similarly, if the object slows back down, we expect that its mass would decrease in due course, as the pressure of movement would be relieved. It is also possible to create a “vacuum” of energy in an object, thereby lowering its mass.

**4.10** Rotation of an object causes its aetheric energy pressure to “spray” outwards, thus decreasing the object’s mass.

**4.11** Rotation of an object can deflect the natural downward movement of aetheric energy out to the sides of the object and “redirect” gravity in a sideways direction, to a degree.

**4.11.1** Dr. Bruce DePalma showed that simply rotating a steel ball and launching it off of a catapult through space will cause it to move faster, fly higher and travel longer than a non-moving ball. The effect works just as well in an airless vacuum.

**4.12** Dr. Hal Puthoff said that “inertia is an electromagnetic force that switches on when you move an object through space.”

**4.13** These effects can be used to create anti-gravity and free energy at the same time.

## **5.1 CONSCIOUSNESS**

As we look over the theories of aether, we find ourselves confronted with a direct spiritual fact: as was said in the Christian Bible, we live in and move through the body of God at all times.

In Chapter Two we saw the clear evidence that the aether is directly connected to consciousness, through findings such as the Backster Effect, the Maharishi effect and the telekinetic experiments with Nina Kulagina and others.

In Chapter Three we learned of Prof. Shnoll's studies proving a clear causative relationship between planetary movements and atomic processes - and this was extended to consciousness as well by Cowan's studies of the effect of planetary movements on financial market movements.

With the new information that we have about the nature of atomic structure, our conventional scientific views seem to be completely inadequate. The only choice that remains for us at this time is to either resist the new information and refuse to acknowledge it, or make some difficult amendments to our most prized paradigms.

And now our scientific ignorance is further exposed by the simple and yet completely new concepts of aether, gravity, inertia and centrifugal force. Without a doubt, Dr. Bruce DePalma's "Spinning Ball Drop" experiment simply could not be possible unless an object was capable of storing and releasing aetheric / electromagnetic energy within its atomic structure, and interacting with the force of inertia and gravity as it moves through space.

Space and matter are fundamentally identical; they simply represent different, interchangeable phases of one unified, vibrating energy source.

With our new realizations about the connection between this same aether and the forces of gravity and inertia, we are truly beginning to see that there is no way for science to slice and dice up the universe into a set of impersonal laws.

Ultimately, the force of gravity is the tendency for this Ultimate Being to seek Oneness within itself, and the force of inertia is the natural energetic resistance that we experience as we move through the body of this Ultimate Being. When all is ultimately a Unified Field of energy, and that energy is ultimately conscious, then we are all part of this vast, interconnected Oneness. Love, instead of being a vague esoteric concept, becomes simply the tendency for the aether to vibrate in greater harmony with Unity.

Our third volume, Divine Cosmos, will feature a full-scale expose' of the problems in the quantum model, and effectively wipe out the idea that our universe is composed of impersonal "particles."

Before we get to those larger discussions, we wish to make a complete case for the existence of the aether, so that the reader is fully educated about its behavior as it relates to science and technology. So, even though our full treatment of quantum mechanics is still forthcoming, we will introduce certain concepts now since they will assist us in our discussion.

## 5.2 VIRTUAL PARTICLES

Any quantum physicist will now tell you that "virtual particles" have been discovered for all of the fundamental components of the atom -- protons, neutrons and electrons. What "virtual" means is that they have concluded that even though these "particles" appear to be precisely the same as normal atomic components, they are not connected to any atom and they wink into and out of existence in very short periods of time!

Even though this is a highly unusual discovery, they continue to see this simply as a function of particles. We have a "Big Bang" where Nothing exploded to become Something, and we now have all these particles scattered about to form the Universe, slowly running themselves down into "heat-death" extinction through the law of entropy, which states that everything must die: all order must dissolve into disorder.

However, when you introduce virtual particles in the mix, we also have to see particles that are appearing and disappearing moment by moment! Where do such particles exist when they are not a part of our "three-dimensional" universe? Would this not be the reverse of entropy?

This is certainly not a popular question to ask in the mainstream scientific world, which continues to humanize the Universe with our own issues. Since the destruction of the earth has become poignantly visible over the last century, it was natural for scientists to assert that the whole Universe was also slipping into inexorable decay.

Fundamentally, it is a model without a Supreme Being of any kind - we are all stardust from a giant explosion that is now fizzling out like a spent bottle-rocket.

So how did the idea of virtual particles get established?

One of the two ways that we measure the quantum realm is with "magnetic particle tracking." An excited burst of energy is entered into a chamber filled with a medium such as fluid or smoke that is illuminated, and the medium in the chamber allows an observer to see the track that the energy makes as it travels.

By introducing a magnetic field into the area that is being measured, the energy will naturally travel in a curve, since we have long known that magnetic fields are always rotating and interacting with quantum energies.

Based on the observation of the different kinds of tracks and how they behave, a set series of rules have been applied that allow these spiraling tracks to be interpreted as representing "protons," "neutrons," "electrons," "quarks" or otherwise. So far, so good, it would appear.

As the quantum physicists studied these tracks in closer detail, they realized that these tracks were not simply moving in smooth curving lines; very minor movements were occurring that caused the tracks to slightly bump back and forth as they moved.

When they analyzed the areas where the "bumps" occurred, they found that these "bumps" followed the same rules that they applied for "particles:" protons, neutrons, electrons, et cetera. And now we have a problem: these "bumps" only occurred for very brief moments of time, even though they were happening constantly.

So, since their model interpreted these movements as the behavior of "particles," but their effects were only visible for extremely short periods of time, they concluded that these were "virtual particles." In other words, they still insist that we must have particles, only now these particles are appearing and disappearing in our existence on a constant basis!

So in the mind of the modern quantum physicist, you could be studying "empty space," have a proton suddenly show up and a few nanoseconds later it will disappear again. And these are not mere random oddities, either - we are talking about something that is happening constantly, everywhere we look, with an almost feverish intensity.

This is definitely strange, and has certainly created even more problems for the contemporary quantum physicists to work with, based on the models that are now in place. If you still believe that there are "particles" in the Universe, then how do you explain a sea of particles that can simply be there one minute and gone the next?

If the universe is simply composed of dead, 'empty' space, then where did these particles come from? Dr. Hal Puthoff explains that this bizarre behavior is due to the nature of the aether or "virtual particle flux" itself - the so-called "particles" are indeed emerging from the "energy of the vacuum."

In a very simplified model of the aether as a fluid, virtual particles could also be seen as being created from a fluid-type medium like water. Whereas an electron, proton or neutron may be seen as a stable, spherical, donut-shaped "whirlpool" in this flowing medium, such as our previous example in Chapter One involving a river, a virtual particle would simply represent a whirlpool that came and went very quickly -- similar to how the ocean is constantly rolling and frothing at the surface. And thus it is the existence of virtual particles that gave birth to the concept of a "seething cauldron" or "raging sea" of energy.

### **5.3 THE CASIMIR FORCE**

The discovery of a "virtual particle flux" helps to explain the peculiarities of the "Casimir effect." This effect is demonstrated by the following experiment. First, you simply start the Faraday cage, which we remember as being an area that is shielded from all conventional energy fields, and you introduce a complete vacuum inside.

Then, inside that area you take two perfectly flat metallic plates and move them very, very close to each other. What do you think would happen? Nothing? We are quick to conclude that this simple experiment shouldn't "do" anything, since we have examples of flat surfaces touching each other all around us.

Why should it be any different if the surfaces are almost microscopically flat and contained in an airless space with no conventional force fields in it? Our intuition will not serve us well when we begin considering this problem, as there is indeed a very real and very powerful effect that takes place.

Under these circumstances, when the two plates are moved together, they will experience a terrific attraction that seems to pull them together with a tremendous amount of force! This is what is known as the "Casimir Force," named after the man who discovered it.

This experimental effect also revealed that if you actually allow the two plates to completely merge, the force that binds them together is so powerful that you literally have to destroy them to get them back apart. Now think about that for a minute; how would one explain a force that could "suck" two plates together?

What would happen if every time you used your car, your shoes would get stuck to the pedals and you couldn't get them off? Driving would be a very dangerous proposition, especially if you were using a standard shift.

That is a rough analogy of what is happening in this experiment, except that in the car there is no vacuum of air and energy and the surfaces of your shoe and the pedal are not flat enough to create the effect.

Now something this simple should have already gotten more attention, and not be such an obscure tidbit of modern science. Most likely, it is not popular because it is a total anomaly that is very difficult to understand or explain with our current scientific models. In order for us to truly understand what is occurring, we will take a similar analogy cited by Ross Tessien, who asks us to visualize a suction cup.

Ask yourself this question: What makes the suction cup attach to the surface? Most people would answer by saying that the cup will stick to a flat surface because it is "sucking" the material and thus attaching itself like glue. Sounds good, right?

However, it is totally the opposite! It is outside pressure and not suction that is responsible for this. Once you push a suction cup onto a flat surface, the edges will make a perfect seal over the surface that does not allow any air to get underneath.

Once this seal is firmly established, you still have ten pounds per square inch of air pressure that is pushing down from the outside. So, it is actually the air pressure that is pushing the cup down, since there is now no air left on the inside to push against the cup in the opposite direction.

In zero-point energy theory, it is now believed that the Casimir force works in exactly the same way. This force is created when the distance between the plates becomes so narrow that no "virtual particles" or aetheric energies are able to fit between them.

So, there is no "sucking" going on at all; in fact it is a complete absence of energy that exists between the plates, aetheric or otherwise. And so, a form of "aether vacuum" is formed between the two plates, where no aether can flow inside the crack. Then, the surrounding "virtual particle flux" or aether pressure pushes the plates together from the outside!

In Dr. Puthoff's model, this pressure is believed to be caused by the "virtual particles" themselves, as they will continually emerge from the zero-point energy long enough to exert a constant force upon the plates, thus pushing them together. Either way, it all comes back to a fundamentally aetheric design, and no other model seems to adequately explain why this incredibly powerful Casimir effect would occur.

Bearing this in mind, we are continuing to see how the background aetheric energy plays a role in the world that we can observe. The Casimir effect reveals to us exactly how much pressure the aether is truly exerting on us. And yet, since Dr. Puthoff and most other theorists believe that it always "cancels out" to zero, we can never detect any major changes in the world around us.

Just like the fishes in the sea, we end up saying, "Water? What water?" Indeed, think about this: do you ever stop and consider the fact that the atmosphere is putting ten pounds of pressure on every square inch of your body all the time?

The pressures of the aether would be far greater, but normally speaking, they are undetectable. The force of inertia is only a vague reminder of how much pressure truly exists, when we consider the amount of energetic activity that is occurring at the quantum level.

So where do we find all this tremendous aetheric pressure, if it truly exists? Do we need to play around with metal plates and subatomic particles to see it, or do we have more familiar examples? As we continue to look at all aspects of aetheric science, magnetism ends up becoming one of the most interesting properties of all.

In contemporary theory it is always fused together with the electrostatic force that creates electricity, but we can demonstrate that it is clearly a very different animal - and in Chapter 18 we will see that it has a very straightforward and yet undiscovered geometric identity.

So here, we will cover the properties of magnetism, as ultimately they are very important in understanding the reality of the conscious aether and how it functions in our universe. If we want to understand this Ultimate Being, we must look at what our scientific findings have taught us, and assimilate that new information into our design.

It is very simple for us to hear certain terms that have been defined scientifically and automatically separate them from any conceptualization of God - but if God truly exists, then all aspects of our Universe must be a part of this Being.

#### 5.4 MAGNETISM AND ELECTRICITY

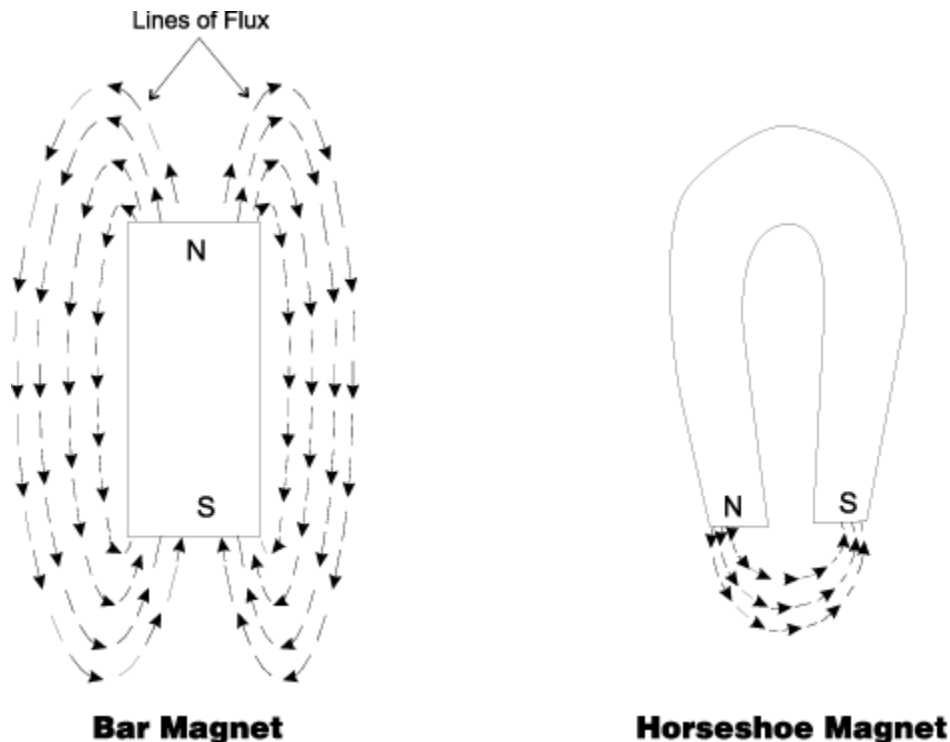

[Note: This diagram and others culled from Rockwell International's Reliance Electric website.]

All of our conventional theories about magnetism and electricity did have their origin in aetheric models, since much of the research was done in the 1800's when these models were still in vogue. The "flux lines" formed by the force from a magnet, which we shall discuss below, were once believed to actually represent a physical substance that could be "cut" and harnessed.

Even though the aetheric models could suggest that the magnets were drawing energy from the aether itself, the original physicists still believed that the force created by a magnet existed within the magnet itself, not as a force that was being pulled from the surrounding energy of "empty space."

This viewpoint has not changed in all the time since it was formulated; however, we will suggest that it must be in error, and the aetheric model provides us with a perfect alternative.

In the experiments with psychokinesis cited in Chapter Two, both electricity and magnetism could be created and controlled by nothing more than the focus of consciousness - and if the consciousness of the others in the room was predominantly negative, the effect was much more draining on the subject.

Furthermore, the energy surrounding Nina Kulagina's body would lose half of its strength when she performed these feats, certainly suggesting that she was somehow able to draw in the aetheric energy from around her and use her body to send and transmute it to the object. So if the energy of magnetism can be created from sheer conscious thought alone, it would be difficult to ascribe it to a force that simply exists within the magnet itself.

Magnetism can be created just like gravity and electricity, straight from the consciousness of this Ultimate Being itself - and in the case of Kulagina, it occurs spontaneously around the object in question, with no measurable line of force connecting it to the person inducing the activity. It literally arises "from the aethers" at the point where it is needed.

#### 5.4.1 E-FIELD AND B-FIELD

Magnetism and electricity are considered to be two components of the same force, namely electromagnetism. Magnetism is referred to as the "B-field" and electricity as the "E-field," and they are graphed out as a unified wave where the E-field is on the horizontal plane and the B-field is on the vertical plane, 90 degrees of rotation away from its counterpart.

This is based upon careful measurements of the properties of these fields themselves, and is considered to be a contemporary fact. The picture below shows us a "conventionalized diagram of an (electromagnetic) wave form..." that was reprinted by Enterprise Mission with permission from *Ultra High Frequency Radio Engineering* by WL Emory, The Macmillan Company.

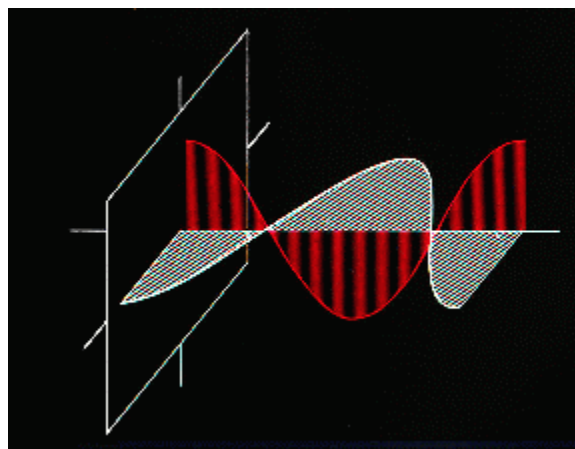

This diagram allows us to clearly see the observed interplay between the two forces. As we look at the picture, we can see that the two fields are in a constant 90-degree relationship to each other. This is called an “orthogonal ” relationship, and it will become very important when we start looking at the theories surrounding the idea of higher “dimensions ” of space.

Since the electromagnetic wave forms the basis of our Universe, all theorists who study the concepts of higher dimensions believe that each higher dimension must somehow be located at another 90-degree turn away from the three main axes of length, width and height that we now see! If this sounds confusing or impossible to you, then you’re on the right track!

No matter where you turn a corner and rotate 90 degrees, you’re still going to end up in what we would call “three-space. ” This puzzling conclusion of the existence of “higher dimensions ” has come from the “crystal ball ” of mathematics.

Certain equations demonstrate that there must somehow be a way for energy to have “more room ” to travel through than what we see in our own “three-space. ” However, this doesn’t make it any easier to visualize. Mathematics can often be used to propose solutions to problems without giving us a solid visual model to work with.

When we start looking at Rod Johnson’s model in our next volume, we will see that there is a very good reason for the shape of this waveform; it ultimately reveals a hidden geometry inside of itself, and this geometry was independently discovered by James Clerk Maxwell in the 19th century and again by Buckminster Fuller, who announced it to the world at his Planet Planning address in 1969.

Johnson was unfamiliar with these earlier discoveries when he independently determined that the same geometric form was being described by the electromagnetic wave. This unseen geometric structure will prove to be a crucial part of truly understanding how the consciousness of this Ultimate Being forms all of reality that we know, from its own “body. ”

#### **5.4.2 DYNAMIC FORCE, STATIC ENERGY**

Let us not forget how important this wave really is; it is the primary means through which the energy of the universe is expressed. Another important and puzzling aspect of the behavior of this waveform is that the two components do not at all move in the same fashion.

Michael Faraday was the first to determine that magnetic fields were continually rotating - and in scientific terms this means that magnetism is a dynamic field. However, he also discovered that:

The electric fields do not move at all; *they require the dynamic movement of the magnetic wave to propel themselves forward.*

The scientific term that was chosen to describe something that does not move is *static*, so the electric field was called an electrostatic field.



This can be visualized in a very simple way. If you think about an object that floats on the surface of the ocean, it is only the movement of the wind and water that would cause it to move forward - and the behavior of the electric field is very similar. If you only looked at the electric part of this waveform by itself, there would be no directional movement within it.

If you ask an engineer why the magnetic field is dynamic and the electric field is static, you will probably get "That's just the way it is" as your answer.

And yet, this is of very obvious importance, as the electromagnetic waveform is the primary means by which energy travels in our universe. And since Nina Kulagina and others can create these forces by a simple focus of consciousness, and in PK tests with Alla Vinogradova these fields would oscillate in tune with her own body, we know that we are dealing with something much more interesting than what we have been led to believe.

This is an active, living energy force in its own right; the primary means by which this Universal Being is continually forming itself. That point cannot be underestimated. Einstein and many others firmly believed that when the Unified Field was discovered, it would prove that all the Universe was composed of electromagnetic fields, not "particles."

The next important terms that we need to cover are "force" and "energy." We have already stated that magnetism was given the term "dynamic" because it is consistently moving, and electricity was given the term "static" because it is motionless.

Since magnetism was observed to rotate and move in set directions, there needed to be a name for that behavior - and it was called a force. The word "dynamic" is a descriptive word, whereas "force" is an active word, like when discussing the force that you would need to push a heavy object. Therefore, magnetism is a dynamic force, meaning that it is a field that is in motion.

Now in the case of the electric field, Faraday discovered that it was essentially motionless, as we pointed out in our example of a piece of flotsam floating on the surface of the ocean. However, that doesn't mean that the field has no energy.

What we do have is a field that radiates energy away from itself. So if we use our analogy of an object floating on the surface of the ocean again, we could see that as it traveled, it would radiate heat energy from the Sun. If you put your hand near the object you could feel the radiant, static energy from it, but it would still need the dynamic force of the wind and water to move it along. This is how electricity is able to power our machines.

So, whereas force was an active word that meant that the field moved in a given direction, the word "energy" was chosen as the word to represent something that radiates while remaining motionless. Therefore, Faraday named the electric field "electrostatic energy."

Some readers may be angry right now for our going into such detail about this and would never want to study and remember this information, as it seems to have no relevance to their everyday life. It certainly seems confusing that these two fields travel together and yet have such different properties. If you are baffled as to why energy would behave like this, you are in good company; up until now, scientists did not have a true means of explaining it.

However, in Chapter 18 we will see that Rod Johnson's model explains it clearly, with a simple geometric design. Although it will sound completely foolish right now, this movement between magnetic and electrostatic fields is actually demonstrating an exchange of energy between two parallel universes, both of which are defined and interconnected with simple geometry!

That is why a description of our world as “three-dimensional ” is incorrect - there is an exchange of force and energy between at least two “dimensions, ” or areas of “virtual ” space, that forms our known reality. So now, we can see that this behavior of the electromagnetic waveform is very important; it contains the secret key to unlock the mysteries of the Cosmic Chess Game, so that we can truly see the “board ” and all the “pieces ” that are in play.

For now, we will continue to investigate the behavior of the electromagnetic wave for how it relates to the aether theories and technology.

## **5.5 LENZ' LAW, MOTORS AND GENERATORS**

For those readers who are unfamiliar with physics, it may be surprising to realize that magnetism and electricity, which certainly seem to be used as two separate forces in our technology, are always traveling together in this fixed 90-degree relationship where magnetism is dynamic and electricity is static.

We know that you cannot have electricity without magnetism and vice versa, and that the two fields will always exist in this very precise geometric arrangement. Our next important realization is this:

By simply passing a wire over the north or south pole of any magnet, an electric current is generated within that wire.

Anyone who has studied basic electronics knows that moving a wire over a magnet will do this, but they usually never ask why. This simple property, known as Lenz' Law, ultimately allowed for the creation of both the electric motor and the generator - and we will explain both of these inventions in order to help us understand what is going on.

The electric motor uses this basic connection between magnetism and electricity to power itself. The first and most simple point that we should realize is that when you run electricity through a wire, that wire will become magnetic.

If we remember the shape of the electromagnetic wave, the dynamic, rotating magnetic force will always travel at a 90-degree angle to the electrostatic energy. When you take a large amount of wire and wrap it around something like a nail over and over again, you will form a coil.

Then, when you send electricity through the coil, there will be a significantly higher amount of magnetic force generated in a coil of wire than you would ever see from a single wire; the magnetic force will multiply as the coil grows larger.

When industrial electro-magnets are built to a custom design, they can be very expensive because of the amount of time and effort that it takes to wind up huge coils of wire to precise specifications. However, once a design has become more common, the electromagnetic coil can be machine-wound, and this makes it much more cost-effective to produce.

This difficulty in custom-designing electromagnets is one of the reasons why so many free energy and anti-gravity researchers have financial problems in trying to build working models of their ideas.

So, if we want to build an electric motor we have to start by realizing that two pieces are involved; a stator and a rotor. The rotor is generally a cylinder-shaped arrangement of electro-magnets, often formed from coils of thin copper wire.

This cylinder has an axle that runs through the center, and it is called a "rotor" due to the fact that the axle allows it to rotate once the motor has been properly built. When electric current is passed through the coiled wires in the rotor, the entire rotor becomes magnetic - and this is how you would create an electro-magnet.

If you simply stopped at this point, you would discover that when you ran current through the rotor, you could pick up metallic objects with it, but as soon as you turned the current off, the objects would fall. This is the standard behavior of an electro-magnet.

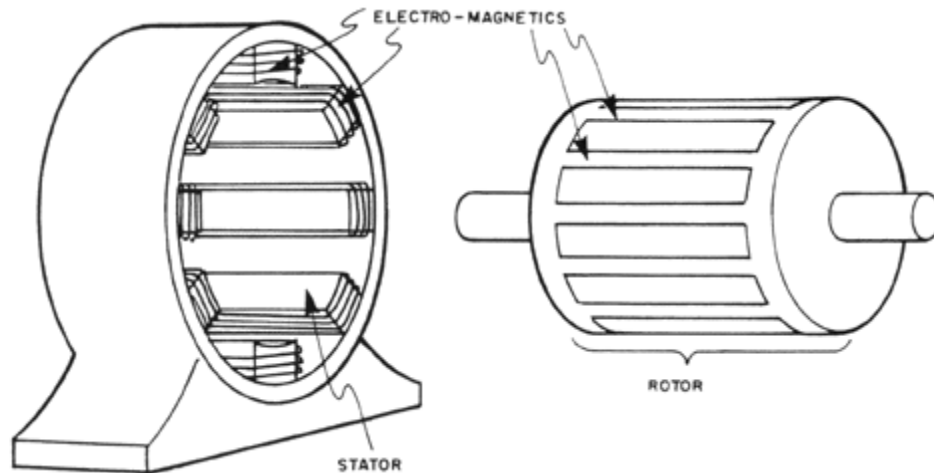

Reliance Electric's diagram of an AC motor, showing the "stator" and "rotor" components.

In order to build a motor, the rotor must be surrounded very closely by a set of permanent magnets. This set of magnets is collectively referred to as the "stator", since remain static or motionless.

[Note: the above diagram is from an AC motor, which is a more complex design that we need not discuss, where electromagnets are also used around the permanent magnets in the stator.]

Typically the rotor is in a cylindrical shape and the stator magnets will be cut to outline the rotor very closely; but they must not ever touch it directly or it wouldn't be able to rotate freely.

Now we get to the fun part, the process by which the rotor is made to spin. When electric current is passed through the copper wire in the rotor, it becomes magnetized, and the rotating magnetic force from the stator magnets will push against the rotor in the opposite direction, thus causing the rotor to move. [See next image.]

This ongoing, rotating magnetic repulsion causes the motor to spin, and the more electric current you run through the central coils of wire, the faster the rotor will rotate on its axle, thus powering your device, such as an electric fan.

In order to truly understand how this rotation takes place, we need to explain the situation a little more carefully. If we look back to the diagram of the E and B-field, we can clearly see that magnetism naturally travels in a 90-degree offset wave motion.

This flow is well-known to move between the north to south pole of a magnet. As we said before, Michael Faraday discovered that all magnetic fields are rotating as they move through space. Thus, due to this spiraling motion from north to south, you can set up a continually rotating magnetic field between the two stator magnets, since one stator magnet will be a north pole and another will be a south pole.

With this continual rotation occurring between them, the rotor can be balanced in such a way as to be continually "kicked" on both sides by the rotational movement between the two stator magnets. In the below diagram, this is explained by seeing how an "induced current flow," which is simply a term for the electricity sent through the electromagnets in the rotor, is working against the spiraling, rotational flow that occurs between the stator magnets.

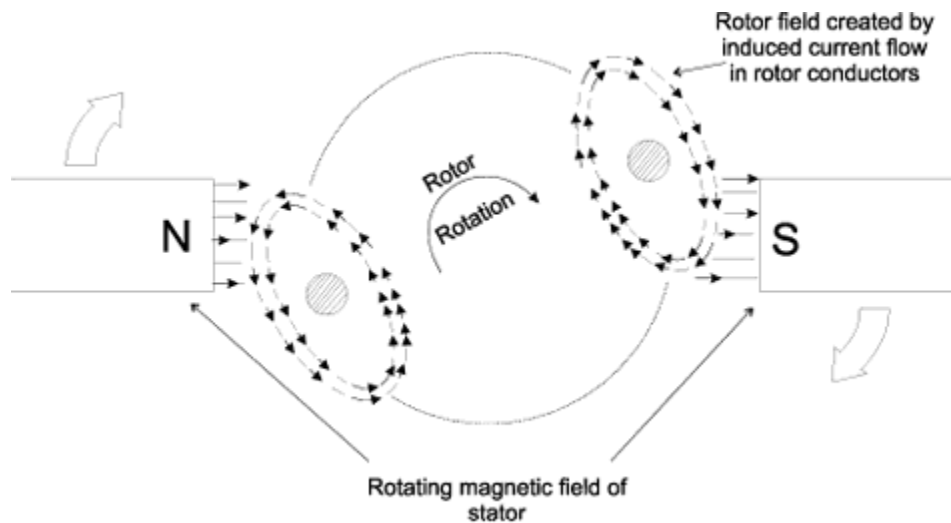

Reliance Electric's diagram of movement within an electromagnetic motor.

## 5.6 GENERATORS OPERATE VERY SIMILARLY

A generator works on exactly the same principle, only in reverse. In this case, you would have a source of mechanical energy, such as a wheel that is being turned by the flowing energy of water from a river, that would spin the rotor from the outside without an electric current. Now, thanks to Lenz' Law, the conducting copper wires inside the rotor will pick up the magnetism from the stator magnets, and turn it into electricity.

It is this "gathered electromagnetic energy" that creates a current through the wire and generates electricity. This simple principle is responsible for the operation of a hydroelectric power plant, where a large river or waterfall provides the mechanical power to turn a waterwheel that then directly turns the rotor inside.

Conventional scientists never bother to ask why electricity can be created by moving a conducting wire through a magnetic field - it is just considered a simple principle of electromagnetism, assigned a mathematical equation and left alone.

However, the simplest law of energy conservation would state that energy can neither be created nor destroyed. If this is true, then the magnet cannot be creating energy by itself - the energy has to come from somewhere.

And yet, a permanent magnet is incredibly durable and will continue emitting magnetism for well over 1000 years with no significant sign of loss. You can still generate as much electricity from it as you want, but many generations would be long dead before it would show the slightest sign of weakening. No one ever worries about having to replace the stators in an electromagnetic motor.

Another interesting property of magnets is that you can rub them over a non-magnetic piece of metal, always in the same straight-lined direction and never backwards, and thus magnetize the object. This is typically done with screwdrivers to enable them to attract screws so that you won't lose them as they are being inserted or removed.

The current theory behind how one magnetizes metal is that the magnetic energy, which is theoretically stored within the magnet since its creation, is simply transferred into the metal. However, the magnet itself is no weaker after such a process than it was before! You can magnetize as many objects as you want and the magnet does not seem to be affected in any way.

And so, in a very real sense, our current physics treats magnets as an impossibility; a source of perpetual energy that almost never expires. If the energy is "stored within" the magnet itself, then where exactly is it coming from, and why doesn't it ever dissipate?

## **5.7 THE MYTH OF FLUX CUTTING**

When a magnet is held under a piece of paper and iron filings are dropped on top of it, you will see a series of concentric circular lines form from the north pole to the south pole. These are referred to as "magnetic flux lines," and they provide a graphic representation of the spiraling fields surrounding the magnet.

The current theory is that when you pass a wire or conductor over the magnet, a process known as "flux line cutting" generates the electricity. In other words, the flux lines themselves are seen as being "cut" by the wire as it passes through them, and the energy that would normally be flowing through the flux lines thus empties into the wire.

This is considered so axiomatic that no one would even bother to think that it could be a faulty model. And even though quantum physicists assume that atoms are composed of particles, no one has ever changed the equations for electromagnetism, which treat it as a flowing (yes, aetheric) field of energy waves that can be "cut" in this fashion. The flowing aether portion of the theory is correct, but the "cutting" is not, as we shall see.

Now remember that in order for flux line cutting to take place in conventional theory, there must be two different speeds of motion; one for the wire (or conductor) and one for the magnet. You can either have the magnet stationary and the conductor in motion, or the conductor stationary and the magnet in motion.

In either case, the relative motion between the conductor and the magnet is supposed to "cut" the flux lines and thus create electric current. If you moved the conductor and the magnet at the same time, then you couldn't "cut" the flux lines and there should be no way to draw electricity through the conductor.

It would be like the proverbial carrot that hangs in front of the donkey - no matter how fast the donkey tries to run to get the carrot, his teeth will never be able to cut into it, because both the donkey and the carrot are moving at the same speed!

### 5.7.1 FARADAY'S ONE-PIECE GENERATOR

Now, whether we like it or not, there is new information that forces us to throw this entire model of "flux cutting" and relative motion between conductor and magnet out the window, or at least subject it to dramatic changes.

For MIT's own Dr. Bruce DePalma has reminded us that electric current can be generated with the conductor and the magnet moving at exactly the same speed - thus eliminating any possibility that the flux lines could be "cut."

For if the magnet is moving, the flux lines should automatically be moving along with it in conventional theory. This bizarre and interesting means of generating electric current was actually discovered by famous pioneer physicist Michael Faraday on Dec. 26, 1831, but until DePalma came along, no one ever paid any attention to it.

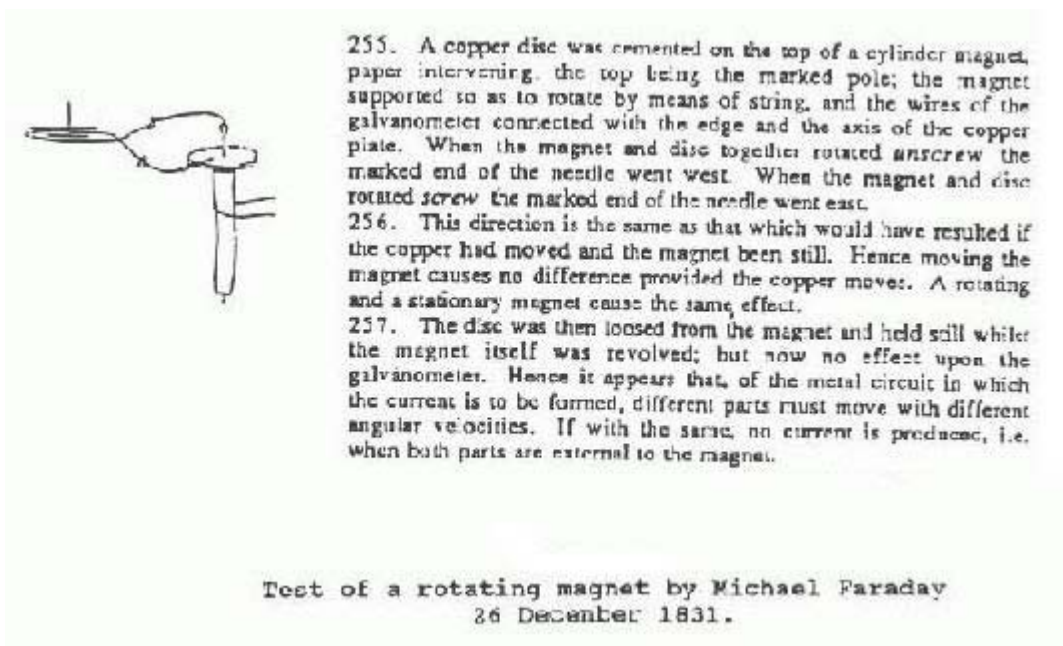

DePalma's prospect is actually quite easy to prove, and he did so many times. To generate electricity without any "flux line cutting," you don't even need anything but one piece that rotates by itself - no "stator magnet" is necessary whatsoever. And that right there would stop most engineers in their tracks.

It is believed that you must always have at least two pieces in a generator - the stationary magnet or magnets and the spinning rotor wrapped with wire. In Faraday's design, seen in the image above, he took a cylindrical magnet, shaped like a candle with both edges cut perfectly flat, and attached a thin piece of paper over its top edge.

Over the paper he cemented on a flat, coin-shaped disc of copper that was several times wider than the cylinder. By its very nature, the copper could conduct electricity, if there was any electricity to conduct. Once cemented together, the two pieces thus had no choice but to spin at exactly the same rate, so no "flux cutting" could occur.

To Faraday's amazement and bewilderment, when he rotated this object he could extract an electric current from it, even though it was only a rotor - there were no other moving parts!

There was a cylinder-shaped magnet and a coin-shaped conductor, and they were both moving at exactly the same speed. All he had to do was to attach a copper "brush" to the outside edge of the conducting disc and another "brush" to the metal axle that touched the center of the disc.

These 'brushes' are just what they sound like; pieces of fine copper wire that can touch an object with enough force to conduct electricity, but also lightly enough to permit it to move. The two "brushes" were then wired into the opposite ends of a galvanometer to measure electric current; and indeed, a current could be detected! (A galvanometer uses a needle that moves when electricity is passed through it, as seen in the diagram.)

No one in the scientific mainstream will believe that this could work if you try to explain it to them, because it violates the "laws" of electromagnetic energy.

This obviously was a cause of great fascination to Faraday, but he had no means to explain it and thus nothing else was done with it. Here, we will suggest that the magnetic energy itself is like a fluid, and by "throwing" or "spraying" the fluid out to the far edge of the conducting disc through rotation, a current is generated.

Essentially, the aetheric energy is being drawn in through the center of the disc and is radiated out the sides. If you could see the basic magnetic energy field as this was happening, it would look like a donut-shaped sphere whose central axis was shared with the axis running through the disc.

The radiated aetheric energy could be visualized in a similar manner as the water that flies off of a wet dog's body when it shakes itself dry, or the water that is pumped through a hose and released by a rotating sprinkler nozzle to water a person's yard.

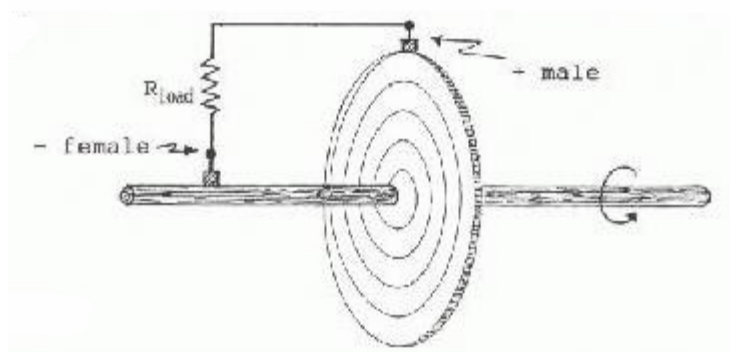

In DePalma's case, he discovered that even having a separate conductor and magnet was not necessary to produce this effect. All he needed was a single strip of flat, magnetized material that could also conduct electricity. This strip

was then fashioned into a flat, disc shaped spiral like a giant lollipop, such that one end terminated at the spinning axle and the other end terminated at the outside rim of the disc. [See above image.]

One pole of the magnet would be wound up into the center, and the other pole of the magnet would be at the outside edge of the spiral. By simply rotating this one-piece magnetic conductor, electric current could be drawn from the disc.

So again, we are doing the impossible -- rotating a one-piece magnetized conducting disc and drawing energy out of it. Now this is where the real problem for scientists comes up: time after time, DePalma was able to show that these "homopolar" or one-piece rotating generators were actually superior in performance to the typical two-piece stator and rotor design that we discussed above.

In fact, these generators were more than superior; they appeared to be impossible, as they created more electrical energy output than it took to spin them. It is from this simple and yet incredible principle that DePalma created his own "free energy" device, known as the N-Machine.

## 5.7.2 THE SUCCESS OF THE N-MACHINE

Now the only way that DePalma's one piece generator can be possible is if a field such as the aether really did exist for us to draw energy out of. Without aetheric energy, we would have a closed "perpetual motion" system that would be thought of as impossible, for it cannot sustain itself without drawing in new energy from somewhere; conventional theory indicates that it will continually lose energy from the friction in the air and the movement of the parts inside.

In DePalma's case he referred to the aetheric energy as the "Primordial Energy Field." And from these principles, DePalma built the large "Sunburst" single-pole generator "N-Machine" in Santa Barbara, California in 1978, which was a further enhancement on the basic idea of using a rotating magnetized conducting disc.

DePalma had the "Sunburst" tested in 1985 by Dr. Robert Kincheloe, Professor Emeritus of Electrical Engineering at Stanford University. In the abstract of his final report, Kincheloe says the following:

Known for over 150 years, the Faraday homopolar generator has been claimed to provide a basis for so-called "free energy" generation... During 1985 I was invited to test such a machine. While it did not perform as claimed, repeatable data showed anomalous results that did not seem to conform to traditional theory...

After the entire report rigorously critiques and examines all of the data, Kincheloe concludes:

DePalma may have been right in that there is indeed a situation here whereby energy is being obtained from a previously unknown and unexplained source.

This is a conclusion that most scientists and engineers would reject out of hand as being a violation of accepted laws of physics, and if true has incredible implications.

And so, with all of this in mind it is clear that DePalma was harnessing electricity from the zero-point energy source that we are calling the "aether." So what exactly is magnetism in the new aetheric theories, and why does it work like this?



We cannot be content with the old definitions when we can now be sure that something quite strange is going on. Two additional discoveries will help to prove the point even more - namely that the energy in the magnet is not being generated by the magnet itself, but from an outside force that is flowing through the magnet.

## 5.8 THE ASPDEN EFFECT

The first discovery that we will mention to prove that outside aetheric force is flowing through a magnet is that known as the "Aspden effect," from Cambridge University's Dr. Harold Aspden. It was presented in the Institute for New Energy's *New Energy News*, vol. 2, no. 10, Feb. 1995. Dr. Aspden's experiment sounded simple enough, and no one would expect anything unusual to happen from doing it.

All he did was to take a magnetized rotor and bring it up to a certain speed of rotation, and then suddenly bring it to a complete, motionless stop, and measure how much energy it took to bring it up to that speed with his instruments. Then, within less than about one minute, he would bring it up to the same speed of rotation again, and measure how much energy it took the second time.

Now any rational-thinking person would expect nothing significant to come out of this. All we are doing is taking the same magnetized rotor, spinning it up to a certain speed and measuring how much energy it took to do that under two different circumstances; the first one from a dead stop and the second one from a recent rotation.

Almost everyone would expect that the amount of energy that it took each time would be the same. There should be no reason for why any residual energy would be left in the magnet after it had just been spinning - it should take the same amount of energy to spin it the second time that it did the first time. Yet, as you already guessed, this is not what happened:

After a magnet has been rotated and then brought to a complete stop, it will then take roughly **ten times less energy to return it to the same speed...** providing that it is spun again within less than about 60 seconds.

Yes, it's really true! You may want to read that sentence again, as its importance can be missed if you are just skimming through - almost anyone can see that this totally violates all known laws of physics. To be more exact, the amount of heat energy that it takes to get the magnetic rotor spinning is measured in joules, and normally in this experiment it would take 1000 joules to get the rotor to spin.

However, if you stop its motion and then start it again within less than 60 seconds, it will only take 100 joules to achieve the same effect! In other words, it is ten times easier to spin the magnet once it has already been spinning.

So how could this be happening? If we remember that the aetheric energy that makes up all of physical matter is creating it moment by moment from a spinning motion, then we can see the following:

The energy within the magnet itself will continue "spinning" inside even when the magnet is not moving.

If we compared a magnet to a glass, then it becomes easier to see. A glass, of course, is a container that can hold a given amount of liquid inside of it. If we see the magnet as a container for a non-physical aetheric "fluid," it becomes very simple. If you were to stir up a glass of water and then remove the stirring rod, it will naturally take less energy to stir up the water in the glass again if you wait less than a minute before trying.

Even though the glass itself wouldn't have moved, the water would still be spinning inside as it remained still. So from this experiment, we can see that it certainly appears that the energy in a magnet itself is in a form of direct fluid motion, which is quite different from how we are normally accustomed to visualizing it.

This should leave no doubt in anyone's mind that we have not yet uncovered the true mysteries of the electromagnetic field. Just as the blood flows through the body, so too does the very conscious energy of Life itself exhibit flowing motion, supporting and upholding the body of this Ultimate Being on a moment to moment basis.

When we think back to the light, sound and geometry components of vibration that were mentioned in Chapter Four, it should come as no surprise later in the book when we start seeing the signatures of these vibrations in many different areas of study, including quantum physics, gravity and astrophysics.

## **5.9 DONALD ROTH AND "MAGNETIC MEMORY "**

The second discovery to prove that magnetism is a movement of energy outside the magnet itself was made by Donald Roth, and presented to the Institute for New Energy at their First Aetheric Conference on July 19-20, 1997. The presentation was later written up in New Energy News, vol. 5, no. 4, Aug. 1997 as follows.

As you read the article, remember that the "magnetic torsion beam" being described is simply akin to a bar magnet that is hanging on a string. We have italicized part of the last sentence for emphasis.

In another experiment, a magnetic torsion beam was suspended and balanced at its center. A strong magnet is then placed on a table with one pole extended toward the suspended torsion beam.

After many oscillations, the beam would be attracted to the opposite pole of the magnet on the table. Donald Roth reports that after five days the magnet can be removed at considerable distance from the balanced torsion beam but that the beam will still be attracted as though the magnet was still there.

And so, it would appear that if a magnet stays in one place for a long enough period of time, it can actually cause the aether flowing through the objects around it to move in a certain anisotropic (non-uniform) direction instead of an isotropic (uniform or "same in all directions") one.

The simple presence of the magnet at a distance provides the extra energy necessary to keep this flow going. This is similar to the idea of a "siphon." If you suck water through a hose and place the bottom of the hose at a lower level than where the water is that you are siphoning from, then the water will continue to empty out of the hose until the entire supply runs out.

This is explained by the fact that there is much greater atmospheric pressure, in pounds per square inch, pressing on the surface of the water, as opposed to the much smaller amount of pressure that is on the water that emerges from the end of the hose.

In the case of Donald Roth's experiment, if magnetism is a "flow" in the aether, it appears that once you "get it going" through a local area of space, it can continue at the same force with the magnet itself being much farther away from the point of action. It is as if a temporary aetheric current is set up in the space-time fabric itself - certainly not a "typical" property of magnetism by anyone's definition.

And right away, when we start looking at these new concepts of magnetism, we should be thinking in our minds of various ways in which these yet-unknown properties could be harnessed for technological purposes. We are already well aware that the psychics in the Soviet studies of psychokinesis were able to harness it by thought alone!

## **5.10 CONVENTIONAL EXPLANATION FOR MAGNETISM AND AETHER ALTERNATIVES**

Now by this point, we must be getting more and more curious as to how the magnet actually functions in this new aetheric model. How does the magnet attract certain types of metal to itself? We know that some form of energy appears to be flowing in through the north pole and out through the south pole, thus forming a magnetic current that creates a dynamic, rotating force.

We also have postulated that nothing exists in the Universe but the conscious aether itself, the lifeblood of the Ultimate Being; so we are not simply studying meaningless information, but learning the specifics of how this Oneness has chosen to exist. Now here is the key that explains magnetism to the conventional thinker:

In a piece of magnetized material, the majority of the molecules are oriented in the same north-south direction.

Providing that you have the right type of metal, you will achieve a magnetic force when this north-south molecular alignment is in place.

In conventional atomic theory, which will be covered in Part Two, there is the assumption that atoms have various "shells" in which "electrons" are orbiting. These assumptions have allowed us to study the atomic level and interpret our data, but they are by no means proven facts, as we shall see.

In this conventional thought process, each metal has a certain number of electrons in its outer shells, and some of these electrons will only "want" to spin in one direction. In other metals such as iron, the outside electrons can spin in many different directions, and the flowing presence of a magnetic field can organize them so that they all spin together. At this point, each atom becomes a miniature magnet in its own right.

Now think about this in terms of aether flow. If each atom of each molecule is formed by a whirlpool in the aether, then there has to be a direction for the whirlpool to be spinning. Most of the compounds on Earth are non-magnetic, non-conducting "dielectric" materials, meaning that they do not conduct electricity easily and their molecules are not all aligned in the same direction.

In this case, as they are continually created by the aether, the fluidlike energy will stream into them from all different directions equally; or to put it in more technical terms, the streaming aether flow is isotropic, meaning "the same in all directions."

In the case of a magnetic material, it appears that the aether flow is anisotropic, meaning that it is not the same in all directions; instead, the flow has a specific orientation. And thus:

The rotating magnetic force of a magnet is nothing more than the aether flow itself as it creates the magnet moment by moment.

Since the molecules of the magnet are all aligned in a certain direction and are good "conductors," aether will only flow through it in a certain direction, like water flowing through a pipe.

The north-south orientation of the "electron orbits" in the molecules of the magnet cause it to draw almost all of the aether that forms it in from the north pole and back out through the south pole, creating a loop.

The magnet is not created like any other object in our physical reality - instead, there is a definite direction to the energy that streams through it. And it is this directional flow of aetheric energy that creates what we term as magnetism.

At this point it is natural to get more specific about how a magnet can attract other metals to itself that are not already magnetized. Contemporary physicists consider it a fact that certain metals have their outer electrons orbiting in such a way that they can spin in a number of directions - but not all metals have the proper electron configurations to allow this to occur.

And as we said, in many metals such as iron, it is currently believed that the outer electrons can realign with the direction of magnetic flow, and thus each atom within the metal also becomes polarized in a north-south direction and thus turns into a miniature magnet while within the larger magnetic field.

In this way, then, the metal is capable of being "reoriented" by the magnetic field so that aetheric energy flows through it in an anisotropic or "directional" fashion.

Then we must ask how this relates directly to aether theory. In fact, it is not much different than when a floating object falls into the current of the river and is swept away by it.

The current of aether that streams through the magnet is in a constant state of movement, and when the electromagnetic fields of certain metals align themselves with that force, the metal is then caught up by that flow and pushed towards the magnet, which becomes like an aether sink, sucking in the aether around it with strong force.

The current will always flow from negative to positive, causing the opposite poles to attract each other, and the atoms in the metal will simply adopt this same polarity when they are subjected to the magnetic field.

## **5.11 THE IMPORTANCE OF VIBRATION**

If we determine that the Aspden effect and other findings of magnetism are truly showing us that the aether behaves like a fluid, then we also know that the fluid can and must be able to vibrate, by definition. Therefore, we can expect

that we should see all of the trademarks of vibration - light, sound and geometry - throughout our Universe, from the quantum to Galactic level.

When we consider all of these points together, magnetism becomes a "whole new ball game," as one might like to say. The implications are quite profound, as it proves that it is indeed very possible for us to harness a limitless supply of this fundamentally conscious "free energy" and never have to worry about scarcity or pollution again.

The only thing that stands in the way at this point are the "powers that be" who are all too ready to squash anyone who tries to build, patent and mass-produce devices of this type. But eventually, if more people become able to perform feats such as Nina Kulagina and refine their operation, then we should be able to power all of our devices simply by psychokinesis!

(Wilcock has two engineer friends with advanced degrees who have used their own psi energy to power their watch batteries, which have remained fully charged for ten years running.)

In the next chapter, we will detail what happens when you put together the magic combination - magnetism and rotation - to produce workable anti-gravity machines. No longer will the idea of antigravity propulsion seem so impossible, once the facts are presented.

## **5.12 RECAP**

And so, as we look over the information that we have covered, the ever-elusive property of magnetism starts to look very different:

**5.1** First of all, a magnetic field can be created through nothing more than the focus of a gifted individual's consciousness, and that force arises from the aetheric flux spontaneously, with no measurable connection to the person.

**5.2** "Virtual Particles" have allegedly been discovered for each of the main components of the atom. Although we will question their true nature in this book, the fact remains that this shows that we are living in a universe of unseen forces.

**5.3** The "Casimir Effect" says that when two perfectly flat plates are brought together in an airless vacuum that is shielded from all conventional electromagnetic waves, a powerful force will cause them to push towards each other. This is another means of proving that the zero-point energy field or 'aether' truly exists.

**5.4** In the new model, magnetism is caused by the movement of aether through an object, and can be created by consciousness alone, as in the cases of Kulagina, Vinogradova and others.

**5.4.1** When we study the electromagnetic wave, magnetism is referred to as the "B-field" and electrostatics as the "E-field." For some yet-unexplained reason, the two are observed to travel at 90-degree angles to each other. Both Buckminster Fuller and Rod Johnson independently discovered a hidden geometry in this movement, which will be discussed later.

**5.4.2** We see that the static energy of the electric field is essentially motionless, and it requires the dynamic force of the magnetic field to propel it forward. We have suggested that the actual electromagnetic wave is occurring as a

result of a flow of energy and force between two parallel universes, for want of a better term, and will go into more detail about this in Chapter 18.

**5.5** Lenz' Law states that by simply passing a wire over the north or south pole of any magnet, an electric current is generated within that wire. This principle can be used to build electromagnetic motors since the magnetic field naturally rotates.

**5.6** The same principle in reverse can be used to build generators as well. Lenz' Law states that conducting wires can gather up the magnetism from a magnet and turn it into electricity.

**5.7** Even though quantum physicists assume that atoms are composed of particles, no one in the mainstream has ever changed the equations for electromagnetism, which treat it as a flowing (yes, aetheric) field of energy waves that can be "cut ". This is called "flux line cutting, " and in order for it to take place in conventional theory, there must be two different speeds of motion; one for the source of magnetic energy and one for the conductor of the energy.

**5.7.1** The work of Michael Faraday in 1869 proved that electric current can be generated with the conductor and the magnet moving at exactly the same speed - thus eliminating any possibility that the flux lines could be "cut."

Faraday and DePalma's "homopolar generator " experiments show us that when a magnet is rotated as a disc, magnetic energy can be caused to eject outward like the water in a sprinkler system, and this energy can be harnessed to create electricity. And the sheer volume of energy that this rotation creates is greater than the energy needed to rotate it in the first place!

**5.7.2** DePalma built the "Sunburst N-Machine" upon these "homopolar generator " principles, as a legitimate free-energy machine. It was tested in 1985 by Dr. Robert Kincheloe, Professor Emeritus of Electrical Engineering at Stanford University, who concluded that "De Palma may have been right in that there is indeed a situation here whereby energy is being obtained from a previously unknown and unexplained source. "

**5.8** The energy coming through the magnet itself appears to behave more like a fluid than a force. When a magnet is spun and then stopped quickly, the Aspden effect reveals that energy is still spinning inside of it.

A rotating magnetic disc that took 1000 joules of energy to reach a certain rotational speed can be abruptly stopped in its rotation, and if it is started again within 60 seconds, it will only take 100 joules to reach the same speed. This suggests that the magnetic energy is swirling around inside like water in a glass, even when the magnet is not moving.

**5.9** The experiments of Donald Roth demonstrated a form of "magnetic memory. " The aether flow known as "magnetism " can be established in one localized area if the magnet is kept there for a long time, and then if the magnet is moved farther away, the force field that it established can continue flowing. This gives definite proof that the energy in the magnet is outside of the magnet itself.

**5.10** The conventional explanation for a magnetic field is that it is caused by a given metal having a special north-south alignment of its molecules. In aetheric theory, this alignment forces the aetheric energy that creates the object to flow through it like a tube in a certain direction, instead of flowing in and out of it from all directions equally. This is the true definition of magnetism.

**5.11** The fluidlike qualities of magnetic energy make a strong suggestion that vibration will play an important part in the behavior of "aetheric " energy.

## 6.1 GYROSCOPES DEFEAT GRAVITY

In the last chapter, Dr. Bruce DePalma showed us that the simple rotation of a magnet, fashioned like a gyroscope, could generate electricity. It is also interesting to point out that gravitational effects could also be produced in DePalma's work with rotating magnets.

Before discussing this, if we go back to his original Spinning Ball Drop experiment detailed in Chapter Four, we can see that definite anti-gravitational effects were observed in the difference between the dropping of a rotating steel ball as opposed to a non-rotating one.

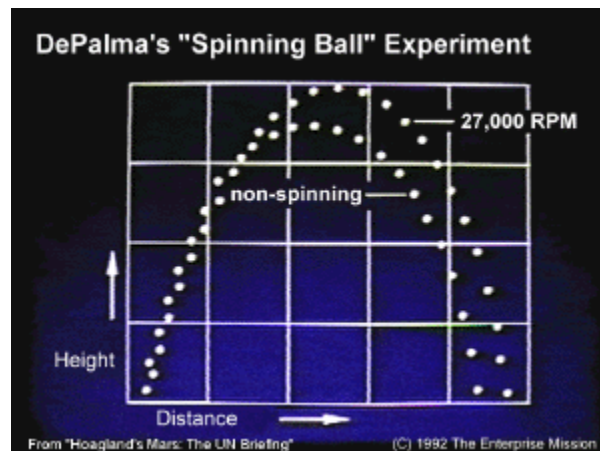

We should remind ourselves that a gyroscope does not "like" to be moved out of its position -it possesses great inertia. You can feel this by trying to turn the gyroscope in your hands while it is moving - it will resist your efforts.

Or you can even balance the bottom axle of the gyroscope on your finger, and dazzle your friends as it tilts almost 90 degrees without falling down. It is these simple principles of the gyroscope that allow our airplanes to remain stable in flight - the gyroscope senses any movement and resists it, which causes the sensitive instruments around the gyroscope to detect the changes and send the corresponding motions to the stabilizers on the wings to keep the plane level.

Without it, a pilot's challenge in trying to keep the plane on track would be a far more demanding task.

We have stated that gravity is the tendency for all parts of the Ultimate Being to seek Oneness, to seek the Center. Thus, when we see this happening on planets, it is simply the force of aether streaming downward into the gigantic planetary body that creates the force.

The Earth's surface is akin to a "screen" that we cannot pass through but the aether can - and thus we are "caught up" in the "aether wind" and continually pushed down by it. However, the aether also streams into all other matter,

including ourselves - so it is certainly possible for other, weaker streams of aether besides the downward direction to be implemented in nature.

These "other streams" with different directions have the same mathematical properties as gravity via Einstein's Principle of Equivalence, and we remember that these forces are called inertia. Therefore, a gyroscope in rotation can harness and "throw off" the aetheric energy force of inertia in the same way that it "throws off" free electrical energy when it is magnetized.

In rotation, the normally downward-streaming aetheric force of gravity is then redirected and radiated out the sides of the gyroscope, thus lowering the object's weight.

As a perfect scientific example of this phenomenon that made it into the mainstream media, we can cite parts of an article that was featured in *The Electronic Telegraph* on Sunday, Sept. 21, 1997:

### **Scientists 'beat gravity' using a gyroscope**

By Robert Matthews, Science Correspondent

A TEAM of scientists backed by a leading Japanese multi-national company claims to have found a way of generating "anti-gravity" using nothing more than a spinning gyroscope. Although the claimed effect is extremely feeble -- amounting to a loss in weight of just one part in 7,000 -- the team insists that it cannot be explained away as experimental error.

Such claims have been circulating for at least a decade and have always been surrounded by controversy. According to conventional physics, it is impossible for any object to generate anti-gravity, or even screen out its effects...

Now new fuel has been added to the antigravity controversy by Hideo Hayasaka and colleagues at the Faculty of Engineering, Tohoku University, Japan, together with Matsushita, the Japanese multinational. The team has carried out a new set of experiments aimed at detecting anti-gravity generated by a small gyroscope.

The principle behind the experiment is very simple. After spinning up the gyroscope to 18,000 revolutions per minute, it is put inside an airtight container and allowed to fall between two laser beams. These record how long the gyroscope takes to fall nearly 6ft between the two beams. Any reduction in the strength of the gravity reveals itself in a slight increase in the time it takes to fall the 6ft.

In a series of 10 runs, the team found that the gyroscope took about 1/25,000 of a second longer to fall when it was spinning than when it was stationary - equivalent to an anti-gravity effect of just one part in 7,000...

This article clearly shows us that the evidence has indeed been "leaking" out into the media, though it was not from any American scientists, nor an American newspaper. Other studies show that this phenomenon is certainly not limited to gyroscopes alone.



In Zhang Chengbin's Ph.D. dissertation *Unified Theory of the Universe*, he mentions the anomaly of how a speeding, rotating bullet can travel long distances, experiencing little or no change in its trajectory from gravity.

In the same dissertation he reports that Japanese scientists discovered that an electric top would measurably reduce its weight when rotating as well. This fact was illustrated in Wang Jiancheng's *Answers to the Unsolved World Mysteries*, New World Press, China, 1994.

So, the Matsushita-sponsored research team's 1-in-7,000 reduction in gravity is hardly cause for great celebration, but it obviously shows us that a fundamental principle is at work that cannot be ignored, and which flies squarely in the face of currently accepted models of physics. [1, 2]

## **6.2 DEPALMA'S FORCE MACHINE**

Thankfully, in Dr. Bruce DePalma's Force Machine, an antigravity effect much higher than 1-in-7,000 was produced, though you would never know it from consulting the mainstream media. In DePalma's device, two magnetized gyroscopes were mounted side-by-side within a cylinder, (see next image,) spinning in opposite directions to each other -- one clockwise and the other counterclockwise.

Both gyroscopes (here referred to as flywheels) were in the same position, with the bottom of their axles pointing straight downward and the top of their axles straight upward.

The cylinder that held these gyroscopes in place was then also made to rotate from its side, causing the axles of the gyroscopes to continually rotate end-over-end in the vertical plane like spokes in a spinning wheel.

Since the inertial forces generated by the gyroscopes cause them to naturally resist being moved out of position, even more aetheric energy could be harnessed by forcing them to do so. And as we said in the last chapter, defying gravity is as simple as gathering some of the downward-streaming aetheric energy and redirecting it off to the side, like the bending of a hose. This redirection can be accomplished by simple rotation.

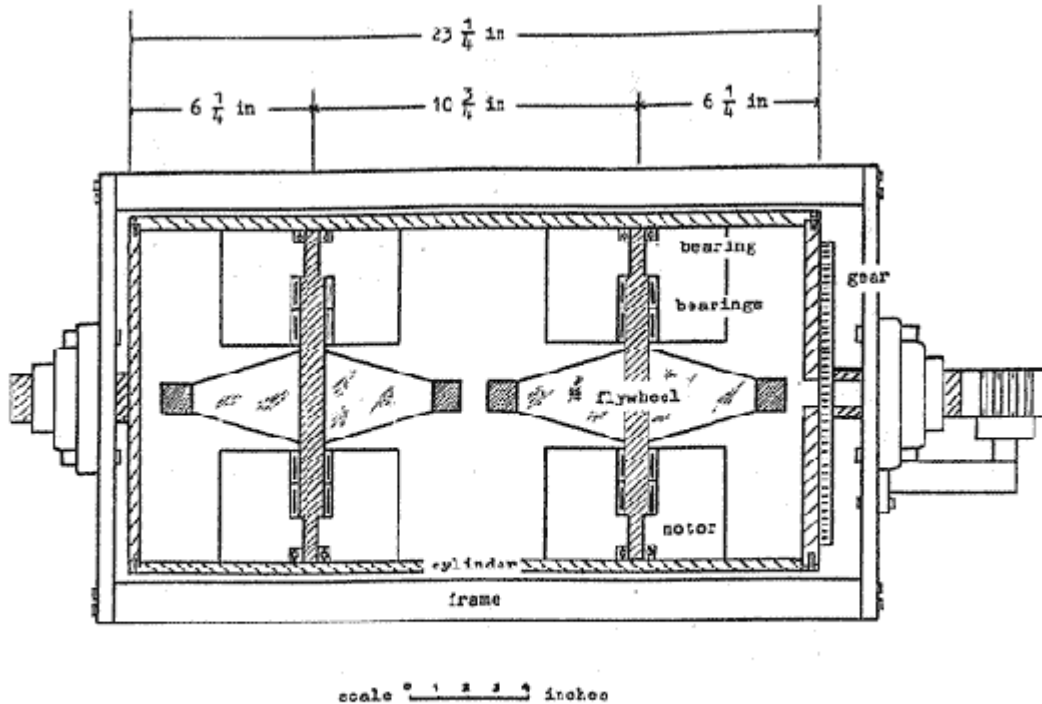

Figure 1. The Force Machine

Dr. DePalma's "Force" machine would initially weigh 276 lbs. before being activated. The gyroscopes would be driven in counter-rotating directions at 7600 rpm each, and then the entire cylinder would be rotated or precessed at 4 revolutions per second. (See the "Precession" section below.) Any movement faster than this would create internal forces great enough to fracture the support axles for the gyroscopes, which would destroy the machine.

Once the Force Machine was running at this speed, it would repeatedly show 4-6 lbs. of weight loss!

This gravity reduction is approximately 100 times more powerful than what was seen in the Japanese experiment cited above. DePalma went on to suggest further design enhancements that would create even more weight loss, such as mounting both counter-rotating gyroscopes on the same axle, thus increasing the strength of the unit and enabling it to precess, or rotate, more quickly.

Furthermore, we must not forget that this same machine can generate "free energy" just like the "Sunburst" N-Machine in the last chapter, simply by setting electrical contacts to the inner and outer edges of the discs on each gyroscope. So the redirecting of aetheric gravitational force and aetheric electromagnetic force are both accomplished through the same means; rotation.

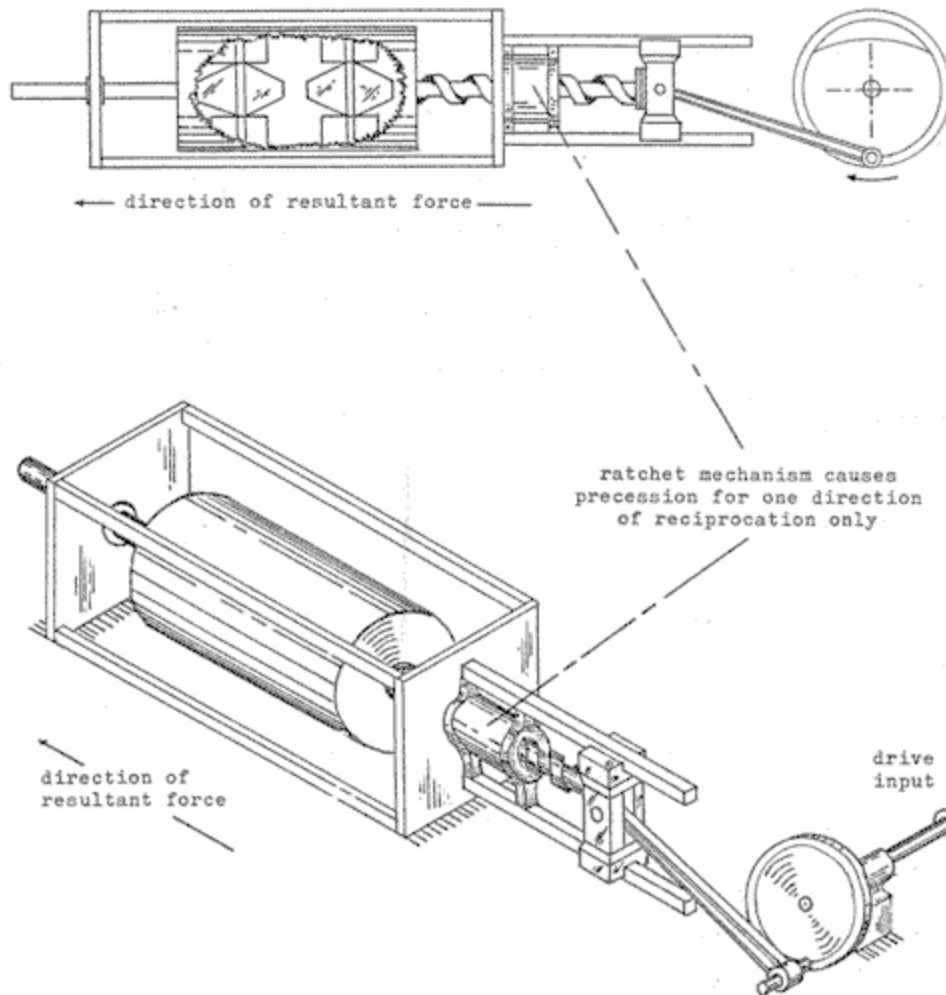

Figure 3. Linear Force Machine (mechanical)

There are indeed many scientists who have approached similar situations as did DePalma, incorporating the anomalous forces of the gyroscope to be used as a method to negate some of the forces of gravity.

Although none of the gyroscope-based machines experience a complete weight loss, one researcher by the name of Geoff Russell was able to create such a device "weighing 22lb, which was able to consistently register weight loss or vertical lift pulses of 20lb, give or take the odd oz".

This and scores of other similar machines, complete with Adobe Acrobat files of their patents, are all located on the "Gyroscopes as Propulsion Devices" website of Glenn Turner, listed below, which is filled with very useful pictures and information for those who are more interested. Another similar gravity-reducing machine was patented by Sandy Kidd, and this is mentioned on Turner's website as well as in an article by Dr. Harold Aspden that we have linked to below.

### 6.3 PRECESSION AS PROPULSION

In order for all the above machines to work, another aspect of a gyroscope's behavior is utilized. A gyroscope will not only resist being moved out of its vertical position, it will also generate force as it attempts to travel in large, circular patterns.

These patterns are most easily seen with a spinning top. As the top begins losing its energy, it never simply spirals straight down in the same direction that it was originally spinning; as it destabilizes, it will always begin slowly rotating or precessing in a slow, even circle that is in the opposite direction to its normal spinning motion.

These circular patterns are known as "precessional" motions, and they are another aspect of a gyroscope's movement that will occur either in air or in a vacuum and can be used to overcome gravity. So whereas the simple inertia in a gyroscope makes it only resist being moved, the precessional forces actually create motion. And this motion is a definite "Force" that can be engineered, as gravity does not have an effect upon it!

Machines such as those built by DePalma and Sandy Kidd position the gyroscopes in such a fashion that their natural "precessional" motion is forced to only be able to travel in one direction. If this direction is opposite to the force of gravity, then the force of gravity is reduced! Below, we have a five-phase diagram co-opted from Glenn Turner's website that shows us a popular method of how this works, where the sequence of motions goes left to right, top to bottom.



We can see how the gyroscopes naturally attempt to precess upwards, and then are stopped at a certain point and forced to go back down. This effect is caused by the fact that the central axle that holds the two gyroscopes is rotating.

In other words, to truly see this in action you must see that the two gyroscopes are whirling around their center axle in giant circles. This creates centrifugal force that presses out from the center. When the gyroscopes move upwards as far as they can go and bump into the metal spool, that same force then pushes them back down.

As we said, the centrifugal force is easily seen by whirling a bucket of water around you in giant circles; if you do it fast enough, no water will spill onto you. And thus, through the clever manipulation of precession and centrifugal forces, this simple design does indeed counteract the force of gravity!

In some ways it could even be thought of as the anti-gravity equivalent to the flapping of wings. Each stroke of the gyroscopes produces an additional burst of lifting power. The next image below is of an actual working prototype from Sandy Kidd that utilizes these concepts - a machine that produces a measurable lessening of its weight when activated.

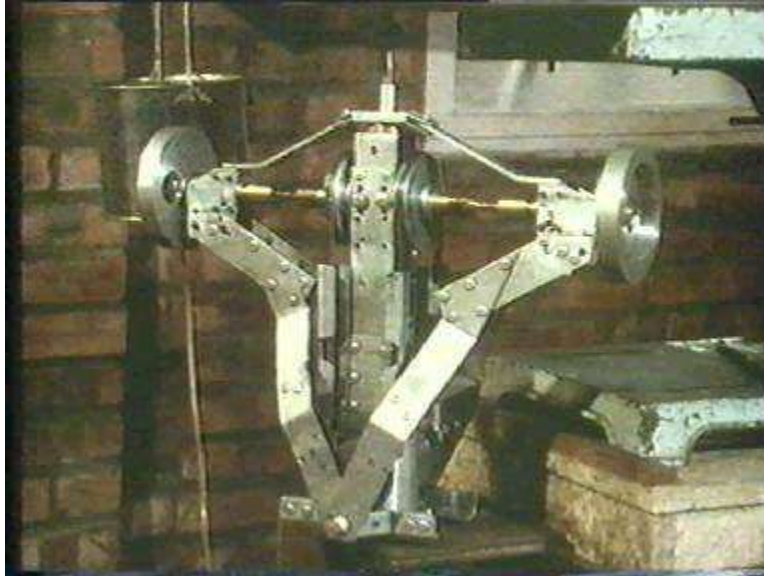

One of Sandy Kidd's gravity-reducing gyroscopic devices.

So, it appears that with the rotating and precessional motions of the gyroscope alone, we can create significant weight loss. We must remember that this weight loss is caused by the fact that the aether is constantly streaming into and out of all matter in order to create its existence moment by moment.

As we said, this streaming movement is the very conscious lifeblood of the Oneness, referred to as the "Breath of the Divine." By rotating an object, such as DePalma did in his Spinning Ball Drop experiment, the object can gather greater amounts of aetheric energy, which we compared to a sponge soaking up water in the last chapter.

In the above cases, effects that are very close to anti-gravity are being discovered and patented, so that whenever society finally realizes that such devices work, these inventors will be able to get the credit that they deserve!

As the prototypes stand right now, they could be used for land travel, such as in an automobile design, or space travel. Since the machines can generate a force in whatever direction you point them, they will work much better in the "vacuum" of empty space, since they would not have any gravity to resist their motion through the aether.

#### **6.4 FINLAND'S ANTI-GRAVITY EXPERIMENT**

Even the mainstream world was privy to a demonstration of how the force of gravitation could be overcome - a story that actually broke into the worldwide media and attracted some attention. This recent discovery was set forth by Dr. Eugene Podkletnov from Finland.

We are including it here because it is a perfect segue into the point of this chapter, which is to show that when the effects of magnetism and rotation are combined together, gravitational effects can be observed.

Of course, very soon after this research was released to the public, a cadre of well-paid "debunkers" with extensive media coverage and advanced degrees rushed in to attack, de-legitimize, ridicule, threaten and effectively destroy this team's work. Since most of the world public assumes that these are the "authorities," they don't realize that there are definite, urgent political motivations that fuel these sudden outbursts.

The global elite do not want these technologies developed independently; they want complete control of the process every step of the way. The entire debacle created such totally unexpected trauma to the group that they completely dissolved their project, even though it was easily replicable, scientific fact. Anyone who wants to make breakthroughs in these areas should expect such events as par for the course.

Podkletnov and his team unexpectedly stumbled over this anti-gravitational effect while they were working with superconductors, which are materials that lose all resistance to electromagnetism at extremely low temperatures.

So, if you have a material that can conduct electromagnetic energy with no loss of power, then you have something very powerful indeed, based on our new understandings of how the aether energy can be harnessed as electromagnetic fields. Philosophically speaking, a superconductor is a material that is very close to being in true harmony with the Universal Oneness, thus providing a perfect means for that conscious energy to travel through it.

From page three of the UK's Sunday Telegraph, September 1, 1993 issue, the following excerpt is a part of what was reported about this remarkable experiment, before the attacks ever started:

The team was carrying out tests on a rapidly spinning disc of superconducting ceramic suspended in the magnetic field of three electric coils, all enclosed in a low-temperature vessel called a cryostat.

"One of my friends came in and he was smoking his pipe," Dr. Podkletnov said. "He put some smoke over the cryostat and we saw that the smoke was going to the ceiling all the time. It was amazing -- we couldn't explain it."

Tests showed a small drop in the weight of objects placed over the device, as if it were shielding the object from the effects of gravity - an effect deemed impossible by most scientists.

"We thought it might be a mistake," Dr. Podkletnov said, "but we have taken every precaution." Yet the bizarre effects persisted. The team found that even the air pressure vertically above the device dropped slightly, with the effect detectable directly above the device on every floor of the laboratory.

Interestingly enough, the key to Dr. Podkletnov's device may not have anything directly to do with the superconducting disc. It appears that the effect is actually being caused by the magnetic forces that the disc focuses and conducts as it rotates.

In the next diagram, we can see that three solenoid magnets, or magnets that create "push" in a certain direction, are supporting the superconducting ring, allowing it to levitate slightly. Then, similar to the engines that we looked at in the last chapter, two more solenoid magnets surround the disc, thus creating a force that causes the disc to spin.

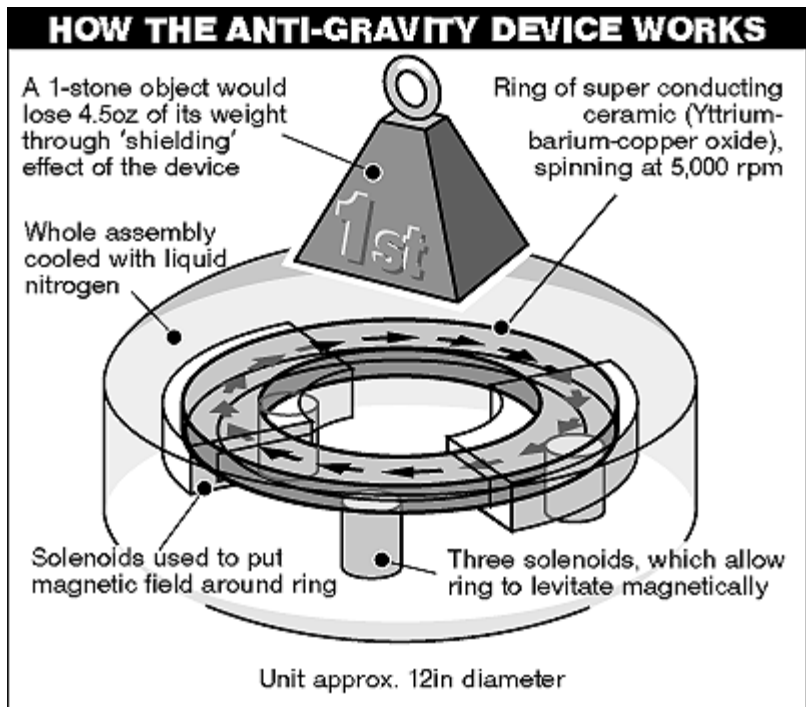

[Note from [Institute for New Energy](#): One stone is about 14 lbs. per Dan York]

Anyone can see that we have two different magnetic fields working together in this device, and the motion of the superconducting disc is causing these fields to rotate. If we remember Dr. Harold Aspden's work which we covered in the last chapter, we would see that when you rotate a magnet, it appears that the magnetic force inside behaves more like a swirling fluid than our contemporary views of energy would allow.

(Dr. Aspden showed us that it takes ten times less energy to rotate a magnetized gyroscope if it had already been rotating less than 60 seconds earlier; the magnetic energy seems to continue to "swirl" inside once the object comes to rest.)

And in Podkletnov's device, we are now seeing a direct reduction in the force of gravity by the combination of magnetism and rotation.

## 6.5 LEVITY

In order to understand how Podkletnov's experiment could be working, we must invoke a new idea in our gravity concepts. Though we will explore this in more detail in Chapter Nine, it is important that we mention it now:

The force known as "Levity" pushes up from the Earth at the same time that gravity pushes down.

Normally the downward force is stronger than the upward force.

The balance between the two is what we have named the "gravitational constant."

This balanced interplay between forces is a natural consequence of the ever-persistent breathing motion that occurs within all matter in the Conscious Universe.

Gravity is action towards a center, and as Walter Russell suggested, when reaching the center new matter and energy is created and radiated outward. This is yet another area in which our "extraterrestrial" communities have made significant progress that we have not yet realized.

And so, "Levity" is created due to the fact that not all of the aether that streams into matter is simply disappearing - just like the whirlpool in the river, some of the water flows back out of the whirlpool after it is created, even though the majority of the water flows down into the vortex itself.

Therefore, some of the aether that creates matter will always be re-radiated back out of the object in the opposite or reverse direction. (We will discuss levity much more clearly in the ninth chapter when we discuss John Keely's system of sympathetic vibratory physics.)

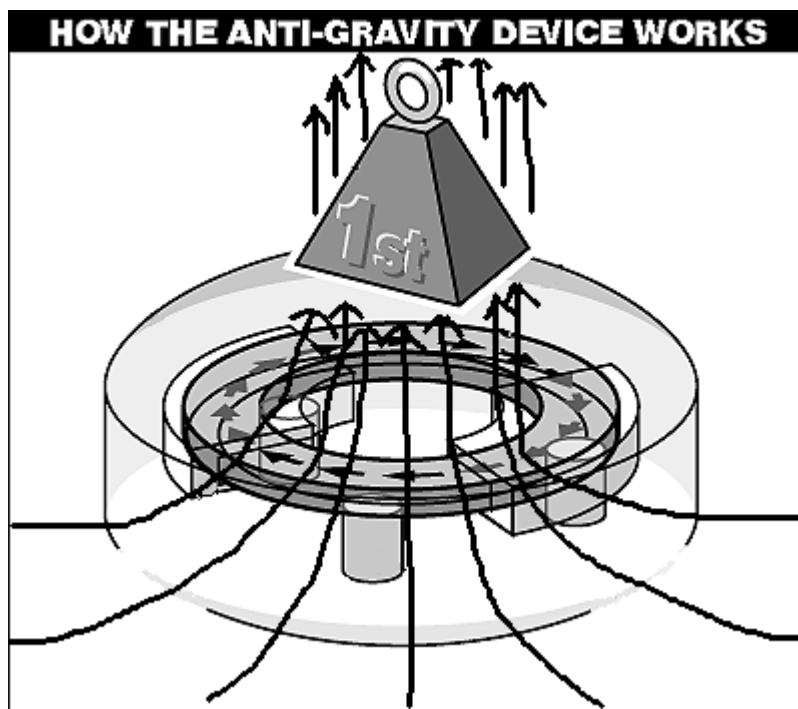



Diagram of "Levity " force in action in Podkletnov's experiment.

If the oppositely-polarized "Levity" force of aether really does exist as Gravity's counterpart, then it could very well be that the magnetism and rotation of Podkletnov's superconducting ceramic disc was enhancing the strength of this upward flow, concentrating it inwardly from the surrounding aether in a laser-like fashion.

If this were what is indeed going on, it would explain why the anti-gravity effect and reduction of air pressure continued in a straight column above the machine and even through the upper floors of Podkletnov's building as well.

To explain in slightly more detail, the upward-pushing magnetic force from the solenoids that levitate the disc create the initial impulse of magnetic energy that enables the system to begin functioning, and the rotation of the superconductors allows these upward-streaming magnetic/ aetheric energies to become quite concentrated.

If you were to look at the above picture again with this in mind, you could draw in some simple lines of force that treated the disc like the drain in your kitchen sink, only upside down. The surrounding aether would flow in through the bottom and "drain out" through the top, continuing on upwards.

## **6.6 GETTING OFF THE GROUND: THE SEARL EFFECT GENERATOR**

And so, the ultimate question that we must ask ourselves is whether or not these technologies that incorporate rotation can actually overcome the force of gravity completely. All of the above machines can certainly create measurable weight loss, but the gyroscope method seems to not quite harness enough energy to produce levitation.

After all, the Finnish experiment by Dr. Podkletnov is only capable of reducing weight by two percent per ring that is used. There must be a better way!

Indeed, other controversial researchers have indeed found a way to work around this problem, and once again magnetism comes to our aid. We remember that magnetism harnesses the aether very directly, and its effects are quite measurable through many of the experiments that we have discussed.

In the case of the Searl Levity Disc, Prof. John R.R. Searl used a series of custom-made magnetic cylindrical rollers that rotated within a nested series of magnetic rings. (The next image shows just one ring, surrounded by one layer of rollers.) A special elemental metal called "neodymium" was added to give the magnets a high degree of strength.

Indeed, if you try to buy neodymium magnets, they are only sold with strict warnings due to their power. If the magnets attract each other together they can shatter, and protective eyewear is necessary to guard against the damage that the fragments from such a collision could create.

So, the amount of energy that these powerful magnets could harness on their own, coupled with their rotation, was more than enough to create levitation. Dr. Searl named this lift "The Searl Effect" for obvious reasons.

Since Prof. Searl's work is the most well-documented account of complete anti-gravity propulsion on record, a bit of historical background is worthwhile here. Prof. Searl worked for the Midlands Board in Australia as an electric fitter in 1949, and conducted experiments in electricity due to his own interest in it.

While working on electric motors and generators, he noticed that the spinning metal parts were creating a small current of electromagnetic energy, with the positive pole towards the center and the negative pole out towards the rim. By now this should be familiar to us. Then in 1950, he was working with rotating slip rings and again measured a small current of electromagnetic energy emerging from the ring edges.

He also realized that his hair would bristle if he allowed the rings to rotate without trying to draw current from them. From these observations, he concluded that the centrifugal force of rotation in the metal was causing free electrons to be spun out.

In this sense, he made highly similar discoveries as Dr. DePalma regarding the ability to draw current out of a rotating magnetic object, only in his case he found the effect in metal that wasn't magnetized.

Furthermore, he believed that the electrons he measured were coming from the atoms in the rotating metallic pieces themselves, and not from the free aetheric energy of the universe. Later, he would obviously change his mind!



Simplified diagram of Searl's system of magnetic rings and rotating magnetic rods.

In order to engineer this principle into a working prototype, he constructed a generator that is now referred to as a Gyro-cell, pictured above. The above image is a simplified version of what actually involves three concentric rings and three sets of rolling cylindrical rods.

A layer of nylon is attached to each ring in order to control the rate at which the electrons emerge, which allows for an even output of energy; otherwise it works in sudden bursts instead of a smooth flow. At first, back in 1952, this was simply built as a generator that was about three feet in diameter.

Searl and a friend tested it outdoors, and a small engine was used underneath the generator to start the rollers in motion around the rings. All Searl was expecting to see was a certain amount of electrical power generated by the device.

This did indeed occur, and at a much higher potential than he had imagined. The effect was strong enough even at relatively low speeds that 10.5 volts was created - and it could be measured by the static charges that would emerge on nearby objects.

### **6.6.1 LEVITATION AND IONIZATION**

As the generator continued to pick up speed, Searl and his friend were shocked to see the generator break away from the engine that had started it in motion and levitate to a height of 50 feet above the ground! It maintained this altitude while continuing to move at a faster and faster rate by itself, and a pink glow of ionized air appeared around it.

While this was happening, the electromagnetic charge in the air around them rose so highly that all the radio receivers in the area spontaneously turned on by themselves, which must have only added to the reeling mystery and fascination that they were experiencing. Finally, the generator shot up into the sky at a tremendous speed and appeared to completely leave the Earth's atmosphere.

Once he saw the end result of his new invention, Searl realized that he was working with a profound new discovery that went way beyond the creation of a generator for electricity. Expecting the levitation effects to continue, he mounted the Gyro-cell generators into disc-shaped crafts that did not need to be attached to the ground to be powered up.

Over the course of time, ten different craft were built, and indeed, the anti-gravity effect was so powerful and uncontrollable in the early phases that many of the prototypes were lost! This continued to be a problem until Dr. Searl learned how to change and control the amount of upward thrust that the rotating magnets were providing.

### **6.6.2 ELECTROMAGNETIC MOVEMENT CONTROL**

The way that he discovered how to control the movement of the craft was quite humorous, and more than a bit embarrassing. After years of work in Australia, Searl had finally gotten enough clout and scientific reputability that he had attracted some media attention. A television crew had arrived to attempt to film this levitating craft in action.

To Searl's horror, although the Levity Disc had reliably worked in front of many different witnesses, in the presence of the camera it would not rise at all! Clearly this must have been a disappointing and highly perplexing moment, to say the least!

However, a short time later this led Prof. Searl to discover that the electromagnetic fields from the camera had directly affected whether the craft would levitate or not. This was his big "Eureka" that led him to develop a way to change the amount and direction of thrust, thus gaining the ability to fly the craft as a remote-controlled device.

The Levity Disc was flown on repeated occasions for many different witnesses, and the entire story is located on his website, linked below. Larger craft have also been built, some at a width of 12 feet and two that were actually 30 feet in diameter.

Numerous articles discuss Searl's invention on the Institute for Free Energy website and in various editions of the New Energy News journal. It is often considered the most popular anti-gravity prototype, because it has also been the most successful.

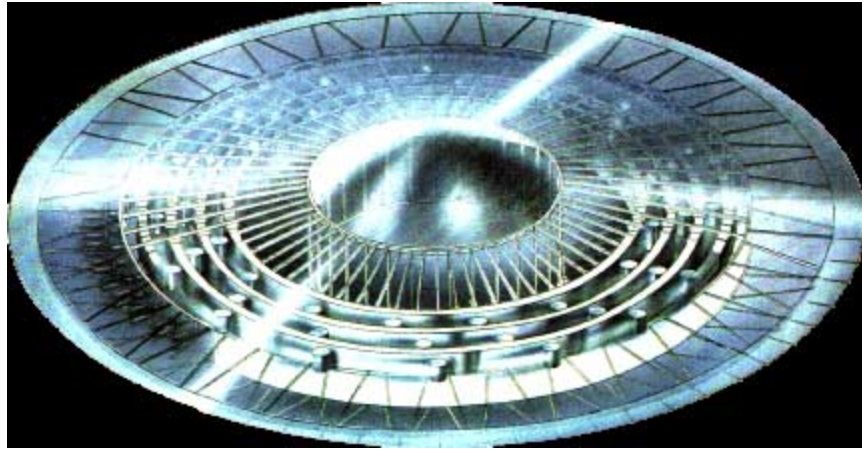

Interior of Searl Levity Disc, showing magnetic rings and rods.

The above image is a see-through diagram of the interior of the flying anti-gravity disc. The three concentric magnetic rings with the rotating magnetic cylinders surrounding them are clearly seen in this picture. Were you to see it with the outside metallic layer in place, it would simply look like a “flying saucer. ”

### **6.6.3 SELF-SUSTAINING POWER GENERATION**

Interestingly enough, with the Searl device we again come back to a working free-energy system as well, as a result of harnessing electricity from the powerful rotating magnets.

John Thomas has studied and written about Prof. Searl's discoveries quite thoroughly in his book *Anti-Gravity: The Dream Made Reality*, and there he reveals that the power source for the device was self-sustaining once a certain amount of current ran into it, in order to get it started.

It literally generated its own energy from the surrounding aether, and thus could function indefinitely with no source of stored power in the device.

This shouldn't be much of a surprise to us, after we saw the “sprinkler ” effect from Dr. Bruce De Palma's “homopolar generator ” and later the “Sunburst ” N-Machine that was independently tested and verified by Dr. Robert Kincheloe.

### **6.6.4 “MATTER SNATCH ”**

We have already mentioned the fact that the Searl Disc could be seen to have a pinkish glow around it, even though it was nothing more than a series of rotating magnets and did not possess any elements that were specifically designed to give off light.

Also, in John Thomas' book it is revealed that the gravity-neutralizing effects included a certain amount of area around the device, not just the device itself. This area was called the "neutral zone" and it extended around the bottom and top of the disc.

So, when it would first take off, some of the land from the surrounding countryside would be contained within this neutral zone and would be caught up in the device's gravitational field as it took off! And thus, Thomas writes:

"It can be seen from the gravity field diagram that a neutral zone appears below the craft as well as the neutral ring above, when the levity drive is on. If matter becomes located in the zone, then it is held there.

In consequence, the Searl craft so far made have left their mark on the country-side in the form of large, neat holes when they suddenly take off. The chunk of earth is taken up with it, [and this is] called "matter snatch..."

The only hazard so far observed is that if the craft hovers for too long near the ground the soil becomes burnt due to the electric currents in it which build up heat. Also the nervous systems of animals are interfered with by ionizing discharge if they come too near. "

#### **6.6.5 THE LONG ROAD TO PUBLIC ACCEPTANCE**

With the Searl Disc we can see that the technology to actually overcome gravity for propulsion already exists. By 1968, Prof. Searl had the SEG ready for commercial use, but he found total failure in getting his invention commercially applied.

The magnets were very expensive to produce, as neodymium is a rare element and all the magnets had to be created at the same time in order for the device to function properly. Thus, it wasn't easy for him to make new prototypes, as proper funding was simply not available.

However, he had all of his home's electric power running off of an SEG, and in 1983 he was jailed for ten months for allegedly "stealing electricity" off of the power grid. The local electricity board did not believe that he was using the SEG for power.

While he was in jail, a "mysterious" fire destroyed all his experimental data and all prototypes that he had created, and his wife left him. By 1990 he was quite despondent and ready to completely give up any further work on the project, but then things started to change; people sent him financial donations to keep him going, and an American offered to publish his book.

Subsequently he was able to publish several more books and there have even been inquiries about a movie of his life being made, with Sir Anthony Hopkins portraying him.

Obviously we have not given all the technical details of how the SEG functions, and we encourage our readers to support Prof. Searl's work by visiting his official website and purchasing some of the reading materials that his team now has to offer in order to get more details.

With the proper funding, the expected results should be immediately forthcoming, and a design application ready for commercial use could be quickly rolled out to the public.

[11/29/07: We have heard rumors that a working Levity Disc is being built in Thailand, and should be ready for public display in 2008. Hopefully there is some truth to the story! You can do a YouTube search on "Searl Effect" and see a small, working prototype of a rotor. It doesn't rise into the air, but it does demonstrate that the basic principle for the motor actually works.]

## **6.7 INDEPENDENT CONFIRMATION OF SEARL'S RESULTS**

Once again, financial destruction and loss of all working prototypes is responsible for why no one has seen or heard anything about the Searl Levity Disc in the media in recent years. In fact, on the official Searl website there is still a fund-raising project in effect to try to finance the construction of another unit.

However, as of late Summer 2000, an independent Russian team was able to verify the Searl Effect in their own experimental version. They did not design their machine to be able to lift off of the ground, but nevertheless they were able to "push it" as far as it could go and register a highly significant anti-gravity effect.

This will be covered in more detail in the next chapter, as it leads us to some startling revelations. So, if a skeptic comes along and tries to discount Prof. Searl's work, the simple fact is that it has finally been replicated by a professional team of scientists. And again, the reason why you haven't heard anything about this before is that it happened outside of the Western media umbrella.

## **6.8 GLOWING SPHERICAL MAGNETISM**

As we examine the information that we have gathered in the last two chapters, we are left with the realization that these anomalous gravity-defying behaviors are due to the natural ability of all objects to harness the unseen "implicate order" of aetheric energy flow that creates all "explicate orders" of the matter that we know on a moment by moment basis.

In our last chapter, we defined magnetism as nothing more than a directional flow of aetheric energy, and rotation is yet another way to create this directional flow.

Thus, when the forces of magnetism are combined with the rotation, the aetheric flow can be harnessed in a much more directional way than could occur with either one of them by themselves; the aetheric currents can be focused in the direction that you want them to go, and the surrounding matter will follow.

If you harness these currents to oppose the downward flow of gravity, then they will reduce their gravitational mass, if not reverse it entirely.

In the next chapter, we will discuss the logical continuation of the arguments that are raised by the behavior of the Searl Levity Disc.

Why is it that when the purely magnetic propulsion system of the disc is powered up, a glowing light is produced? Could this have any connection with the currently inexplicable phenomenon of "ball lightning?" What we will see is that understanding this phenomenon of "glowing magnetism" provides a vital key in decoding the hidden structure of the Universe.

Many different theorists, both past and present, continue to turn up this information and relate it to the harmonic and energetic properties of a sphere, hence the term "spherical harmonics." Indeed, we can show without any doubt that the Unified Field theory must incorporate spherical harmonics; it is the only system that will allow for the various observed forces such as gravity, magnetism and electrostatics to synthesize together.

Any magnet of any kind will automatically produce a spherical field around itself, and let us not forget that the "curved" space around the Earth formed by its gravity is required to be spherical in shape as well. And as we have stated previously, the sphere is the ultimate Unity of vibrations for all other forms of three-dimensional geometry that we will be looking into.

Then, in Chapter Nine we will see that there might even be simpler ways to create anti-gravity, using nothing more than pure sound resonances. There is indeed evidence to suggest that if an object can be brought into perfect harmonic resonance, its resistance to the downward-streaming aether flow of gravity can be dramatically reduced, hence forming an anti-gravity effect yet again.

## **6.9 RECAP**

**6.1** Hideo Hayasaka and colleagues at the Faculty of Engineering, Tohoku University, Japan, together with Matsushita, the Japanese multinational, found a weak but measurable 1-in-7,000 decline in gravity by dropping a rotating gyroscope. In Dr. Bruce DePalma's case, two spheres are catapulted into the same trajectory, one rotating and one stationary. The rotating sphere shows distinct gravitational and energetic changes when compared to the non-rotating sphere. This shows that simply rotating an object decreases its observed mass.

**6.2** Dr. Bruce DePalma's Force Machine demonstrated an effect approximately 100 times more powerful than the 1-in-7,000 gravity reduction seen in the Japanese experiment. This effect was produced through rotation and "forced precession."

**6.3** Data from Sandy Kidd and Glenn Turner show that the force of "precession" can be used in a variety of propulsion and anti-gravity devices, with significant effects.

**6.4** Dr. Eugene Podkletnov discovered an anti-gravity effect above a rapidly spinning disc of superconducting ceramic, which was suspended in the magnetic field of three electric coils, all enclosed in a low-temperature vessel called a cryostat. This actually appeared in the mainstream media but was quickly suppressed and recanted due to the extreme political forces that oppose these discoveries.

**6.5** The force known as "Levity" pushes up from the Earth at the same time that gravity pushes down. Normally the downward force is stronger than the upward force, and the balance between the two is what we have named the "gravitational constant."

**6.6** The Searl Levity Disc showed a complete overcoming of the force of gravity. Prof. John R.R. Searl used a series of custom-made magnetic cylindrical rollers that rotated within a nested series of magnetic rings to produce this effect.

**6.6.1** Once powered up, the Searl Levity Disc would rise to a height of 50 feet above the ground and remain stable as its speed of rotation continued to increase. As this occurred, all the radio receivers in the area spontaneously turned on by themselves. A pinkish glow of ionized gases would be seen around the device as this occurred.

**6.6.2** In the presence of a television camera, the Levity Disc would not rise at all! Prof. Searl later realized that this was due to the camera's electromagnetic field, and from this discovery he was able to devise an electromagnetic control system that allowed him to move the disc as it traveled through space.

**6.6.3** The Levity Disc had an increasing, self-sustaining energy current that would move through it once it reached a certain rotational speed.

**6.6.4** Some of the land from the surrounding countryside would be contained within a spherical "neutral zone" that formed around the disc, and would be caught up in the device's gravitational field as it took off.

**6.6.5** By 1968, Prof. Searl had the SEG ready for commercial use, but he found total failure in getting his invention commercially applied. In 1983 he was jailed for ten months for allegedly "stealing electricity" off of the power grid. A "mysterious" fire then destroyed all his experimental data and all prototypes that he had created, and his wife left him. By 1990 he was quite despondent but he then received financial donations, book offers and possible movie offers, which did not actually pan out.

**6.7** As of late Summer 2000, the Roschin / Godin team in Russia was able to replicate Prof. Searl's results. This will be covered more in the next chapter, and lends dramatic scientific validity to the entire picture.

**6.8** In the next chapter, we will cover the spherical properties of "glowing magnetism" and examine clear evidence of their appearance in nature.

#### **MASTER LIST OF ANTIGRAV / FREE ENERGY LINKS:**

[Note: If any of these links are broken, copy and paste the link into the Wayback Machine at [www.archive.org](http://www.archive.org) and you should find it. All were online as of 2000-2001.]

[Official Website of "The Searl Effect"](#)

[Glenn Turner's "Gyroscopes as Propulsion Devices"](#)

Everything you ever wanted to know about gyroscopes and how they can be used for propulsion. A complete list of patents that can be downloaded, and a plethora of illustrations and articles.

[Sandy Kidd's Gyroscopic Levitation Device:](#)

Here Dr. Harold Aspden comments on Kidd's device, also mentioned on Glenn Turner's website.

[Bruce DePalma's Main Website:](#)

All documents from Bruce DePalma's research, including pictures and descriptions of the Spinning Ball Experiment, N-Machine and Force Machine. Also included are links to Paramahansa Tewari, who worked with similar ideas on a very advanced theoretical / mathematical level.

[Institute for New Energy:](#)

Considered by many to be the master website for learning about cold fusion, free-energy aetheric engines, anti-gravity propulsion and all related topics.



[Keely Net Alternative Energy - Master Website:](#)

This site also is absolutely loaded with information about aetheric theory and the applications of it as applied to free energy and anti-gravity. Content draws heavily off of the harmonic aether theories of 19th century physicist John Keely.

[Theories of the Aether Website:](#)

This is an excellent source for those doing specific research on the aether. Many different articles will be found at different levels of technical sophistication- and there is a great degree of commonality among them, which we have attempted to fuse together in this book.

[Leading Edge Research Alternative Energy Technology:](#)

This site is another extensive list of links, many of which are already indicated above but also many more that are not. Its value was indispensable in our research on these areas.

[Oil City Research Page:](#)

A collection of interesting tidbits on aether and the like from a fossil fuel research team that is unafraid to look into new energy concepts. Contains latest version of Zhang Chengbin's work on the "Unified Theory of the Universe."

[CSETI Additional Position Papers:](#)

Contains a small section of links on alternative / suppressed technologies, among other things.

## CHAPTER 07: THE AETHER AS SPHERICAL LIGHT AND SOUND

[Tweet](#)

### **7.1 GLOWING MAGNETISM / BALL LIGHTNING**

We started off this book with a description of the energetics of the aether, followed by the idea that the aether is arguably a conscious energy, the working substance of the Ultimate Being that we are all very much a part of.

Then, we suggested that the basic components of vibration - light, sound and geometry - would ultimately reveal themselves to be a fundamental aspect of how the aether functions in the creation of space and time. In the last three

chapters we have now seen that this same Breath of Life can be harnessed by rotation and magnetism, as well as consciousness, to produce anti-gravity and potentially limitless free energy.

While we investigated several devices that could deter gravity somewhat, the Searl Levity Disc appears to have been able to completely defeat it. (For those interested in pursuing these matters further, Townsend T. Brown also appears to have produced working anti-gravity propulsion through the use of extremely high levels of electrostatic energy.)

Our knowledge of the aether, its intrinsic connection to consciousness, its background structure as a fluid-like energy substance and its ability to be harnessed with technology is certainly expanding as we proceed.

What we will begin to see in this chapter is how our three main components of vibration - light, sound and geometry - emerge as the unifying forces at work in the structure of the aether. The geometry we will deal with in this chapter is that of the sphere, as its presence is most fundamental to all future chapters, and we will focus on the connection between aetheric energy, spherical geometry and light.

In the last chapter we mentioned John Thomas' article, which gives tremendous insight into the operation and properties of the gravity-defying Searl Levity Disc and how it relates to magnetism and aetheric energy. [Link to this article.](#)

In this excerpt from Thomas' book *Anti-Gravity: The Dream Made Reality*, the work of obscure Austrian physicist Karl Schappeller (d.1947) is cited to explain the unusual effects associated with the Searl Levity Disc, and to provide a tangible explanation for how it might function.

As we indicated before, one of the most bizarre effects that was produced by the Levity Disc was a pink to blue glow that would be seen around the craft while it was flying in air.

This is called "ionization," and it occurs naturally when gas molecules get charged up with enough electromagnetic energy that they start emitting photons; emitting light.

Since the Searl Effect is caused by nothing more than powerful rotating magnets, this bizarre visual effect makes us ask some deeper questions as to the nature of magnetism itself. Why indeed can certain forms of high-energy magnetism be seen to glow, and does this glowing have anything to do with the reason for why the Levity Disc defeats gravity whereas other devices have not?

Schappeller's work, which provided inspiration for Professor Searl in the first place, appears to have the answer.

In brief, Thomas' article gives us a view of magnetism that should now be familiar to us, namely that magnetism is an area where the surrounding aether is being gathered together to flow in one direction. In reality this is not hard to envision, because we have already shown how a magnet can concentrate, focus and circulate the aetheric energies in a much more directional fashion than a non-magnetic material could.

In this article the term "Primary Magnetism" refers to the magnetism that we are normally aware of in everyday life, and Thomas defines it as "a large-scale movement of aether." In the following passage, (which we have edited to enhance comprehension, removing some words and adding others) Thomas goes further to suggest that:

Primary magnetism [causes] a gathering of the surrounding [aetheric] space fabric and from [that fabric,] it [releases] more fundamental energy as an intensification of the primary magnetism.

At a certain stage, the system [reaches] an equilibrium [or balance, as it is] gathering [the surrounding aetheric] space fabric, and from [this fabric,] energy [is then precipitated, or produced.]

When the [density of the energy gathered by the magnetic force in an area of so-called "empty space"] [reaches] a required level, matter [will be] produced. The system would take up a spherical form in the "natural" state and become what Schappeller called "glowing magnetism..."

The existence of "ball lightning" has now been accepted but as yet [it has] eluded explanation, except that attempts have been made without the usual mathematical substantiation.

The peculiar anti-gravitational [effects created by ball lightning,] the inductive effects [where the lightning is seen to draw in energy from around itself] and the fantastic energy of ball lightning fits neatly in with Schappeller's theory of glowing magnetism.

If magnetism is nothing more than a large-scale movement of aether, then according to the theory, when you have enough of it in motion, a critical threshold is crossed where it starts to produce light (create matter) and radiate heat.

At this point, we will bring in an excerpt from Dr. John Nordberg's website writings on ball lightning, in order to better familiarize ourselves with this intriguing phenomenon. Nordberg has taken this same concept of spherical "glowing magnetism," which he simply calls a "ball-of-light," and expanded it into a comprehensive "grand unification theory" of physics that attempts to unify the various forces together and resolve the current incompatibility between Relativity and Quantum Mechanics.

Ultimately he believes that the atoms and stars alike are all composed of "balls of light" with similar qualities. Nordberg's theory began with his simple observations of phenomena such as ball lightning, which cannot be explained in conventional models:

There is a very interesting form of lightning called "ball lightning." Many scientists do not believe in this form of lightning because there is no physics theory that can satisfactorily explain it.

Obviously, the Ball-of-Light Particle Model [where all fundamental atomic and subatomic particles are seen as self-sustaining balls of light] does explain ball lightning. Ball lightning are balls-of-light [as in the model of physics described here.]

Ball lightning can be created when two strokes of lightning collide. Typically one stroke travels from cloud to ground and the other stroke travels from ground to cloud. When they meet, if polarized correctly, some of the energy can wrap around itself in a semi-harmonic pattern...

Sometimes the two strokes are so highly polarized and have such highly matching wave patterns that more than one ball will be created. A string of balls is created. This is the so-called "bead lightning..." Sometimes, cloud-to-cloud lightning will create ball lightning that is visible from the ground or from planes.

## Sizes of Ball Lightning

Ball lightning seems to come in certain sizes. One common size is about the size of a basketball. The limit to the size is based upon the energy in the strokes that create them.

Ball lightning appears to be inherently nonharmonic. For example:

- the balls decay quickly -- they are notoriously difficult to capture on film or video
- the balls radiate photons -- after all, they can be seen
- sometimes ball lightning is observed to decay by simply "fizzling" out
- more commonly, ball lightning is observed to decay dramatically in an explosive fashion

As a more personal example of ball lightning, this author's own father (Wilcock) witnessed it while lying ill in his parents' lakeside cottage in the Adirondack Mountains of New York State, an area which often had very intense lightning storms.

With explosive sound, brightness and power, a four-inch wide ball of light entered the house through an electric outlet and burned a long, straight line into the carpet as it traveled, exiting with an explosion at the outlet on the opposite wall. Some fire and damage were sustained but he remained unharmed.

## 7.2 AETHER = LIGHT

So, with Dr. Nordberg's data on ball lightning, we can better understand the implications of Schappeller's research, which created the intellectual foundation for the successful prototype of Dr. Searl's anti-gravitational Levity Disc.

Here, we can see that the spherical shape is the "natural state" where the aether flows into our world and reaches balance. It seems that in the case of ball lightning, we have an opportunity for energy to reach this perfect balance naturally, and sustain its existence for a short time.

With Schappeller's work, this could actually be reproduced in the laboratory, as Dr. Searl later also replicated. The one key point that we should see here is that when aetheric forces bleed through and reach a point of balance in our own real space, they are visible as light that naturally assumes a spherical shape similar to a soap bubble, in varying sizes.

We have already demonstrated various pieces of evidence, such as the Aspden effect, that suggest that the aether behaves like a fluid in vibration. Remember that either light waves or sound waves could travel through water, and you would still be able to detect them; the water would simply be the medium through which they were traveling.

Similarly, it would now appear that light is also the traveling of an impulse of energy through the fluidlike aether medium. We have already suggested that the only thing that "truly" exists is the aether medium itself; light and sound and geometry, as well as other forces such as electromagnetism and heat, are simply different frequencies that vibration takes on as it travels through the medium. That point cannot be underestimated; nothing else truly "exists" besides the aetheric medium itself.

Einstein assigned the highest possible speed of matter / energy vibration in the universe to light; therefore, light could be seen as the ultimate way to describe aetheric vibrations, to give the aether a simple, unifying identity.

We have already suggested that "love" is simply the tendency for the aetheric medium to vibrate in greater unity with Oneness, and now we can add to this the idea that light is the highest vibration of the aether that we can see. Therefore,

**Light and Love are interchangeable terms; both represent a vibration of the aetheric energy that is in greater unity with Oneness.**

Schappeller and Nordberg both suggest that the sphere is the natural "balance point" for magnetic / aetheric energy, and it is then visible as light. And as we suggested earlier, the simple geometric definition of a sphere is that it is the ultimate unification and balance point for any vibrations.

As anyone can see from the films of astronauts in the Space Shuttle, liquids in zero-gravity or free-fall will naturally form into spherical blobs as they float; this is as a result of the equal air pressure pushing on them from all directions.

The sphere is the shape of perfect equilibrium that will occur in a fluid when internal and external pressures reach a point of exact balance. Therefore, since the aether appears to have fluidlike properties as well, we could also see the sphere as representing the ultimate equilibrium, the highest vibration, the purest Unity that there could ever be.

**Light, Love and the Sphere are all interchangeable definitions of aetheric energy that is in unity with Oneness.**

Remember that Light maintains the highest frequency of vibration of all the various energetic fields that we have discussed, in the same sense as the sphere represents this geometrically. Therefore, it should come as no surprise that many different spiritual traditions focus exclusively on Light and Love as being the primary identity of God.

In the more esoteric traditions, such as the Pythagorean and Platonic mystery schools and many Eastern teachings as well, the sphere was also associated with God, though often concealed in two-dimensional images of a circle, or especially a circle with a dot in the middle, which also could refer to the Sun.

What we are truly seeing is a visual representation of the highest and most refined vibrations within a fluidlike aetheric medium, which we suggest forms the body of the Ultimate Being.

This is a very significant point, as both Dr. Nordberg's theory and Schappeller's "glowing magnetism" concepts suggest that this mysterious, conscious aether energy / Oneness that we call God is pure Light. For the modern mainstream scientist, this is often seen simply as a fanciful metaphysical belief that does not have any relation to "true reality."

Light is seen as a photon, which is just one of a variety of "particles," even though the particles have a peculiar tendency to show up just as easily as waves, depending on how you measure them! But with our new information, even though the aether behaves like a fluid whereas light does not seem to have any immediate fluidlike properties, it should nevertheless be easy for us to conclude that the terms aether and Light could be interchangeable.

**Spherical, loving light is the primary definition of aether, since it is the highest form of its vibration; it is the true nature of the Ultimate Being.**

From the scientific perspective, we can see that the connection between aether and Light must be possible from Einstein's work with relativity, where energy and mass were directly and mathematically interwoven with the speed of light. As everyone knows, in an atomic explosion, a tremendous amount of blinding white light is released; light so powerful that it can incinerate anything in its path.

It is this very "flash point" that reveals to us that matter, which is formed from the aether, is nothing more than a highly-compressed form of light. And so, many theorists such as Nordberg and various contributors to KeelyNet and the Institute for New Energy believe that in the aether and in physical matter as well, light is in a condensed form that can later be released.

In fact, the aether is the condensed form of all vibrations, whether light, sound, heat or otherwise.

### **7.3 ENGINEERING SPHERICAL LIGHT**

Going back to Thomas' article, we learn that Schappeller created a device called a "dynamagnetic generator," which would allow him to produce a sustained ball of "glowing magnetism" in the laboratory setting. In so doing, he was able to prove that his theories regarding the aether and magnetism were actually engineerable. Thomas' rather complicated description of this device is as follows:

"Basically, [the device] consists of a pair of coils wound on to a hollow ceramic [sphere,] contained [inside another] sphere [of] iron. The coils are of copper tubing packed with a permanent electret material...

[Electret material is capable of storing an electromagnetic charge, so with the copper coils Schappeller created a sphere that can focus electromagnetic energy.] This constitutes the dynamagnetic generator.

To convert the energy into mechanical energy, a rotor is used, also made from copper tube packed with electret. The sphere functions only after the electret material is polarized.

[This step of "polarizing the electret" means that you must introduce an electromagnetic charge into it before the device will work. And then, once again we have the power of rotation involved in creating the glowing magnetism. In this case the rotation is produced from the rotor described above.]

Because of the terminology in the Schappeller theory, it is naturally difficult to follow, that is, apart from the strangeness of the concepts.

After several readings, one might conclude that "glowing magnetism" or aether precipitation, starts if the electric and / or magnetic fields reach enormous values at a given point. It seems that this is the function of the stator device outlined above. "

We can see from the brief description above that Schappeller's spherical chamber was creating an enormous compression of aetheric energy in a small point, similar to the forces in a thunderstorm that can create the anomaly of ball lightning.

The spherical shape of the iron and ceramic core acts as a magnifying glass for all of the electromagnetic energy, directing it into the center when the machine is operating at full capacity. And it is at this central point in the sphere that "the electric and / or magnetic fields reach enormous values. "

(As we shall see in the next chapter, Sonoluminescence works almost exactly the same way, but the spherical chamber focuses sound instead of electromagnetic energy to produce this glowing aether vibration of light.)

Later in this same article, Thomas relates this finding of Schappeller's to the behavior of the Searl Levity Disc, since a clear "glowing magnetism" ionization effect was seen around the disc when it was traveling.

And we remember that ionization is the charging of gas molecules with enough energy that they start to release photons. Therefore, Searl took the initial idea of Schappeller's invention and transformed it into a design that could be transformed into an anti-gravity craft.

#### **7.4 "VACUUM DOMAINS "**

Russian scientists Dr. Alexey Dmitriev, V.L. Dyatlov and A.V. Tetenov published an article with the intimidating title "Planetophysical Function of Vacuum Domains " in English on the Millennium Group website, which goes into far more detail regarding "balls of light " than we may have otherwise expected. Ball lightning is only one of a number of natural phenomena, which Dmitriev et al. refer to as "vacuum domains " or "VDs. "

This term seems to be rather uncomfortable for some people, as we often think of the word "domain " as meaning "an area that a person (such as a king) rules over. " And the letters VD don't sit well in the English language, for obvious reasons.

In this model, the word "domain " is used more generally, as "a given area with clear boundaries, where certain rules apply. " And we remember that the word "vacuum " is often used interchangeably with "aether, " as aether is "the energy that will always exist in a vacuum. "

So, to put it simply, a "vacuum domain " is an area with clear boundaries where the aether is directly bleeding through to our physical reality and creating a measurable energy change. Ball lightning would obviously be one example of a "vacuum domain " in action.

The true value of Dmitriev et al.'s paper is that many more natural phenomena are identified besides ball lightning; furthermore, we learn a lot more about how these phenomena behave, and a full range of mathematical equations are applied to help explain what is happening. For our purposes in this book we won't cover the equations, but the properties and behavior of these "vacuum domains " will certainly be very interesting to us.

Most importantly, say the authors, in a vacuum domain (VD) the forces of electromagnetism and gravity work directly together, whereas outside the VD they do not. By definition, the VDs can penetrate through any kind of matter, since they are composed of the very energy that matter is made of.

The authors produce equations to demonstrate that gravity waves are automatically transformed into electromagnetic waves inside the VD, and these waves are then directly visible to us as light. In the aether theory, both gravity and magnetism are simply different forms of aether in movement, so it would make sense that if you can create a large enough degree of movement of aether in a small area, then you would see the fields working together.

According to Dmitriev et al., these VDs emerge all throughout the Earth, whether in the magnetic field, the layers of the atmosphere or within the Earth itself. Since the VDs can be quite large and can command the force of gravity, they are capable of having incredible power.

A tornado is one such example of a VD in action, say the authors. These powerful areas of energetic force can also produce “enormous torsion stress ” in the Earth that in turn affects the so-called “plate tectonics ” of the continents and the seismic activity throughout the Earth. They create sudden, anomalous changes in the Earth’s magnetic field in localized areas as well.

#### **7.4.1 PROPERTIES OF VACUUM DOMAINS**

The main properties of VDs are expressed in this paper as follows:

1. They are capable of penetrating through matter at will;
2. They can emit or absorb light and other electromagnetic radiation in the wide frequency range;
3. They can cause electronic devices to stop functioning because of the strong electric field that they produce both inside and outside of themselves;
4. They will exhibit a measurable magnetic field;
5. They can distort gravitational fields, causing objects to levitate or to become heavier;
6. They can cause air and dust to rotate inside of themselves, since they are in a constant state of rotation;
7. They can have explosions that do not necessarily change their form and size;
8. They possess a definite geometric form such as a sphere or “ellipsoid, ” which is basically a stretched-out sphere; and lastly,
9. They will be seen and reported far more frequently in the years when the Sun’s activity has reached its peak.

So, with these properties we now have a much firmer understanding of what a “vacuum domain ” actually is, what it looks like and how it functions. We are then given a list of ten different anomalous phenomena that are all explained as being different forms of VDs.

It is very important to remember that not all of them clearly exhibit all nine of the above properties, but in each case there is enough evidence to suggest that they all have a common explanation:

#### **7.4.2 ANOMALOUS “VACUUM DOMAIN ” PHENOMENA**

**1. Ball lightning.** According to the authors, this is the most well known and studied anomalous phenomenon, and it displays all nine VD properties. Most scientific papers do not mention any effects of levitation occurring with ball lightning, but this is simply because the ball lightning is so small that it would be hard to see. The typical formation of



ball lightning will be between 10 and 30 centimeters in diameter. Some have reported seeing dust particles rotating inside of ball lightning.

**2. Natural self-luminous objects or “plasmoids.”** Here we have objects that may be seen with the naked eye as bright balls of light, and may show up even better on film if they are photographed. They usually appear near the areas of the Earth where there is the most energetic activity, in the form of earthquake-producing faults in the crust.

They have similar properties as ball lightning, and in this case the large-scale effect of levitation is more likely to be seen. The authors refer us to a case in Russia known as the “Sasovo explosions,” described by A. Yu. Olhovatov, where these formations were witnessed as being capable of levitating objects as well as producing the explosive effects mentioned in property number 7 in the above list. The images in the study show these clearly.

**3. Poltergeists.** While some cases of “haunting ” may involve real entities in a nonphysical form, others appear to be cases where a VD penetrates through the walls of a person’s home. In these cases, a ball-like, slightly glowing energy is seen that can levitate objects, create electric and magnetic fields and also cause damage to people.

If the phenomenon is seen to occur repeatedly, it might be because the house is built over an area of the Earth that is more energetically active and thereby capable of producing these formations.

**4. Tornadoes.** All of us are familiar with the violent funnel-like cloud formation of a tornado, which can create immense damage and levitate objects essentially intact. The study of tornadoes is so important that Dr. Dmitriev actually tackles it in an entirely separate paper entitled “Electrogravodynamic Concept of Tornadoes,” also on the Millennium Group website at [www.tmgnow.com](http://www.tmgnow.com).

Most of the nine properties on the list are associated directly with tornadoes, including the appearance of visible forms of light. In the “Tornadoes ” paper, Dmitriev refers to the following case:

In 1951 in Texas a funnel passed over an observer at a height of 6 meters, the interior having a diameter of about 130 meters with walls of 3 meters’ width. Inside the hollow there was a brilliant cloud. There was no vacuum inside, because it was easy to breathe.

In other cases, “swarms of ball lightning ” and other luminous phenomena including “continuous glowing light ” and “continuous lightning ” are seen in and around tornadoes.

Other anomalous phenomena involving gravity and the interpenetration of matter will be discussed in later sections of this book. The idea of an “air suction ” to explain the levitation effects with a tornado is not sufficient, especially if a person can breathe inside.

**5. “Angels.”** This term refers to a special kind of radar interference that all systems must contend with. In the early days of radar, there were cases where blips appeared on the screen that appeared to be airplanes or missiles.

The engineers realized that these were not actually physical objects and referred to them as “angels, ” and now radars are built so that they will not mistakenly detect these formations. The authors suggest that “angels ” are the same as “natural self-luminous formations, ” as they both occur directly over tectonic faults. In the case of NSLFs, they are detected just above the faults, whereas “angels ” are typically detected some kilometers above the faults.

**6. Small Comets ” or “Atmospheric Holes. ”** These were seen on ultraviolet images of the Earth taken at high altitudes. About 20 times a minute, large black holes are seen to form in the upper ionosphere, each of which is approximately 30 miles wide.

The conventional hypothesis, put forth by those who discovered this, is that these holes are being produced by “small comets ” of snow and ice. However, if this many comets were constantly hitting the Earth, they should be also colliding with the Moon as well, but there are no tremors on the Moon’s surface to correspond with such events. Therefore, the authors consider that these may be vacuum domains as well.

**7. Ionospheric and atmospheric explosions.** In this case, the name is self-explanatory. Many people have heard spontaneous loud explosions with no apparent source, and without any signs of inclement weather. These explosions are associated with luminescent forms of spherical geometry that have also been seen to penetrate matter.

**8. Lithospheric pipe explosions.** These are phenomena that occur within the Earth’s lithosphere or crust, which can conduct electromagnetic fields and can have an elastic, pliable quality. Geologists have observed sudden pulses or explosions of heat within the lithosphere, where an elongated elliptical tube known as a “kimberlite pipe ” is formed immediately thereafter.

They are self-luminescent explosions that produce electromagnetic emissions, and, at least in Russia, they are considered “the great mystery of modern geology. ”

**9. “Sprites ”, elves and jets.** These anomalies have only been recently discovered, and conventional explanations for them are still fairly weak. Above thunderstorm clouds, brief and very large flashes of light can appear up to 100 kilometers in height.

They often appear blue or red depending on their height. Most importantly for Dmitriev et al., these formations are often associated with the most intense groupings of lightning strikes that are moving from the clouds to the ground. This suggests that the contact of the lightning is somehow combining with energy in the Earth to cause these luminous flashes to form.

**10. Luminescences associated with earthquakes and volcanic eruptions.** According to Dmitriev et al., almost all earthquakes and volcanic eruptions are accompanied by the sighting of luminous formations. They may be seen before, after or during the events themselves, and therefore are very closely timed with the events.

### 7.4.3 "NASA UFOs" - VACUUM DOMAINS IN SPACE

If we look back to number 6 on the list, "Small Comets" and "Atmospheric Holes," we see that it appears that about 20 times a minute, the Earth's ionosphere is reacting with something that is creating 30-mile wide black spots in the ultraviolet spectrum.

Dr. Dmitriev et al. speculate that these reactions are caused by VDs that are moving through space. The main problem was that there was no proof that such VDs existed... until now. Early in the year 2000, a great deal of excitement was generated in the Internet UFO community over what appeared to be "UFOs" that were filmed on many NASA shuttle missions.

Millions watched a short video promo for a UFO documentary film entitled "Evidence 2001: The Case for NASA UFOs," which featured the work of Mr. Martyn Stubbs.

Mr. Stubbs worked for five years to analyze over 2,500 hours of NASA space shuttle transmissions that he recorded on a total of 520 video tapes. He used satellite dishes and other equipment from the Vancouver Cable Station, where he worked as a manager, to record virgin copies of the video from every Discovery mission that was conducted since 1991.

When we look at what he discovered, we can clearly see that it is another example of "vacuum domains" at work, and provides the missing link to explain why the Earth's ionosphere is being struck 20 times a second by the so-called 'small comets.' We will post excerpts from the [Citizens Against UFO Secrecy \(CAUS\)](#) website to help illustrate what was done.

*"...Weird shapes are shown massing on the shuttle equipment while the astronauts talk openly with mission control about the spooky event.*

Dr Guido Nigro, Director of the Search for Extraterrestrial Intelligence, SETI, observatory was reportedly visibly shaken after viewing part of the footage. "I am very impressed," he said. "This time we are not talking about footage taken by someone with a home movie camera.

"Maybe this will prove there is something else that we are not aware of, at least officially." The footage was aired at the ninth International UFO conference in Nevada and shows two bizarre phenomena...

Martyn's breakthrough came when he watched a \$100 million satellite cable snap taking the tether 12 miles into space during NASA's Discovery missions. "From the moment it broke to the moment it's many miles away a spherical phenomena follows and swarms round it, all going in different directions.

"When the astronauts were asked how far away the tether was, they replied more than 80 miles." He claims the distance and the size of the sphere-like phenomena must be huge.

NASA has officially guessed that the shards are ice specks, but Martyn scoffed: "I've never heard of a six-mile long ice crystal that's spotted crystal clear 100 miles away and there are hundreds of different examples.

"Once NASA said they were shooting stars or meteors, but we have documentation that shows that NASA didn't have an answer. "When you see those pictures, the pictures of the shuttle today and the Mir space station, you see the same spherical phenomena."

Martyn also describes how astronauts on the STS-80 shuttle mission could not open the door due because the phenomena was BLOCKING it. "The phenomena was all around the door, and they (the crew) were moving the door and trying to get it open.

"A flight or two later, the astronauts were commenting right on the feed that something had come right through the door, that they were seeing these flashing colored lights. To make this discovery he painstakingly examined more than 500 eight-hour video tapes.

He said: "I can't tell you what is there, but I can tell you what shouldn't be there. It's not a matter of finding something, it's more about collecting, studying and analyzing. Eventually the jigsaw puzzle will come together."

So, we can see that these spherical phenomena follow all the same properties as Dmitriev et al.'s vacuum domains. First of all, let's consider the experiment that was conducted on Shuttle mission STS-75. In this case, a satellite was extended away from the Shuttle on a 12-mile long tether.

According to an article by *The Enterprise Mission* and others, the true, hidden purpose of this experiment was to attempt to harness "hyperdimensional " or aetheric energy from the vacuum. In this case, the experiment was so successful that it actually melted the super-strong tether completely, which was obviously not expected, and caused the satellite to glow with ionizing radiation as it drifted away from the Shuttle!

When we combine Stubbs' observations with this, we can see that because of its sudden high electromagnetic charge, the satellite then attracted many VDs to itself that had been freely drifting in space and transferred energy to them, making them easily visible and possibly expanding their physical size as well. The resulting effect, seen by millions on the Internet when the movie was first released, is quite remarkable.



STS-75 Spherical Phenomena

The two above images are both of the same striking formation that was captured on the videotape of this event, slightly delayed in time from one to the next. The obvious black hole in the middle of this formation could be where the rotational axis of the VD is flowing through, and we'll be discussing this central axis further ahead.

When we look to the image on the right, we see the ring formation on the left image spreading out into a spiral shape, which is exactly what we would expect from the energy of a VD, flowing out from, say, the northern pole in a spiraling, rotating fashion as it makes its way to the southern pole.

The notch at the lower left is at the opposite end of the object's direction of travel, and may be formed by the VD's outer field being disturbed by the dust and plasma in space as it moves along, creating a windsock effect over its entire surface except for in the middle, where the greater strength of its axis holds in more material.

Another clue that these are energetic formations is that they were repeatedly seen to have a luminous "wobble" to them, and they drift relatively slowly, without exhibit the speed and abrupt, angular changes in movement typical of most UFO sightings. This certainly does not rule out the possibility that what we are seeing is indeed some form of extraterrestrial spacecraft.

In the case of STS-80, a VD penetrated the Space Shuttle door, and its gravitational effects stopped the door from being able to open. At the same time, its natural luminosity was emerging through the door as well. Obviously this fits all the characteristics that we would expect of a VD, including the ability to penetrate matter, gravitational effects and luminosity.

Furthermore, it could be that the VD was attracted to the door because it was the only area on the outside of the Shuttle that had a direct passage to the inside of the Shuttle, where there could well have been a greater amount of static electric charge that it was attracted to. This mission's video data also produced images of luminous formations with the characteristic black dot in their centers.

A series of images from Stubbs' NASA UFO footage are collected at Jeff Rense's website and can be perused for further study: <http://www.rense.com/nasaufo/nasaufo.htm>.

And by far, the next image, showing the "swarming" effect of a very large number of spherical VDs around the tethered satellite, is the most provocative.



STS-75 Footage of Spherical Phenomena Surrounding Tethered Satellite

The other phenomena that Stubbs discusses in the videotape is a very fast streak of light that can only be detected by slowing down the film to one-frame-at-a-time speed. These streaks are most likely formed by spherical VDs as well, only in this case they are difficult to capture on film because they are moving much more quickly than the slow-drifting VDs that were more easily observed.

All together, it would seem that these VDs, here referred to as “NASA UFOs,” are being created by the intense electromagnetic activity of the Sun. Once released, they then move out through the Solar System via the Solar Wind, which is a continuous stream of gas, dust and energy that the Sun gives off.

When the Sun is more active, more of the VDs are created and therefore more of them interact with the Earth’s electromagnetic fields as well. This clearly explains why Dmitriev et al. noticed that the number of reports of natural self-luminous formations and other related phenomena are always seen to increase during times of high solar activity.

## **7.5 INTERSTELLAR DEMONSTRATIONS OF VDs**

The power of the “vacuum domain ” or “glowing magnetism ” can also have an effect on a star that has recently exploded, causing anomalous spherical formations to appear.

Dr. Nordberg reminds us that if there is an explosion in the vacuum of space, conventional science would say that it should move outwards in all directions at the same time, forming one large cloud of gas that is roughly sphere-shaped.

However, if we look at the exploding star Eta Carinae, we can see that it has formed two expanding spheres with a disc of light in between them.



Current physics has no model of "spherical harmonics" that would account for any force that could hold together such a structure as this in the airless vacuum of space. Here we can see that similar to ball lightning and other VDs, the two sides of the explosion are being effected by spherical electromagnetic fields and thus holding their shape.

If there were no aether pressure forming the two spherical shapes, then the explosion should have simply expanded straight outward from the center.

## 7.6 THE "ELECTROMAGNETOTOROID:" A STEP CLOSER

Yet another physicist, Charles Cagle, has independently tackled the problem of creating a unified field theory at the quantum level that is based on the visual model of a "ball-of-light," spherical harmonics or a "vacuum domain. "

Tying all of this back into the quantum level is indeed very important, and this is just the beginning. In this case, Cagle refers to the model as an "electromagnetotoroid," which is certainly not an easy word to remember. The information regarding this approach is on Cagle's website, [www.singtech.com](http://www.singtech.com).

In Cagle's case, he has used this new understanding to develop a "free energy" device that is based upon fusion -- so here again, we are seeing workable prototypes emerging from these new models. We will leave it up to the reader to peruse the explanations for the particulars of Cagle's designs.

Our only point to add is that this model incorporates the fact that the sphere should actually be seen as a torus, meaning that it has a hole running through its center as the axis of rotation. (Actually, from the below diagram we can see that Cagle has two tori inside of each other. This propensity for "balls within balls" is a very important behavior that will come into play when we discuss the geometries involved in the structure of our Octave of dimensions.)

## Archetype Form or Neutral Macroparticle Structure

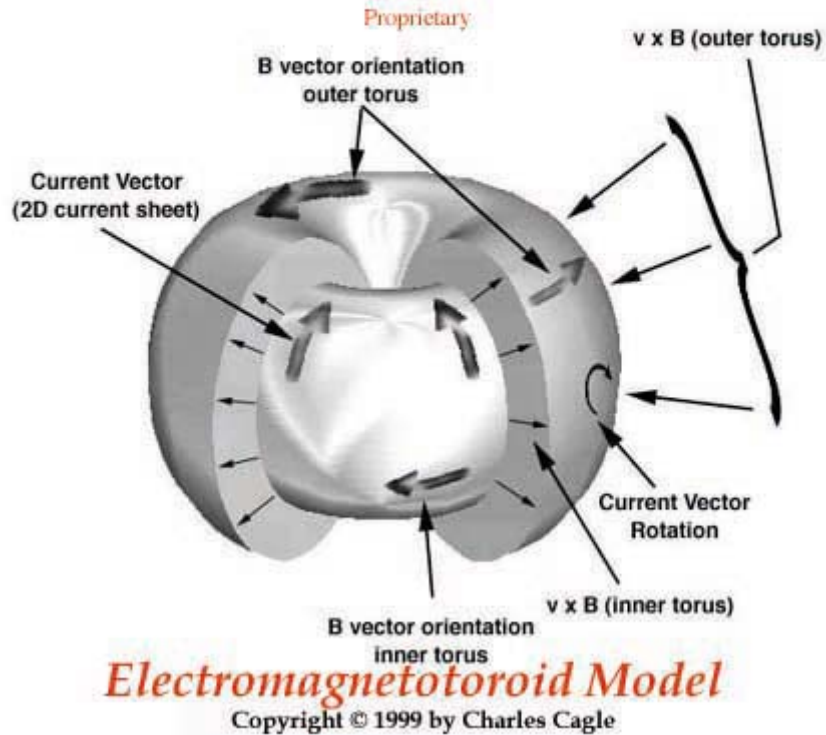

### 7.7 THE TORUS

To properly visualize a torus, we must see that the harmonic sphere is shaped more like an apple, with a hole extending directly through its center. Another way to think of it would be as akin to a donut or inner tube that was expanded into a spherical form. (See above image.)

There are common examples that can help us to visualize how energy flows over and through a torus like this.

Many of us have seen those rubber tube toys that are made from balloons filled with water and that fold in on themselves, acting as another form of a torus shaped as a cylinder. When you try to squeeze the balloon in your hands it will immediately slip out, because it is actually a perfect closed loop - the entire outside folds through the entire inside.

As soon as you try to grab it, the outer skin rolls into the inner portion, so that even if the part of the balloon skin that touches your hand doesn't slip, the balloon still slides out of your grip. A smoke ring works the same way - it continues to spin around itself as it moves forward, so the outside and the inside are really the same surface in motion - the object only has one side, one surface, but it is still capable of having internal / external movement and circulation.



Based on all available evidence that we will review as this book progresses, the toroidal structure must be included in the final design of the sphere or VD. This is what allows any VD to sustain itself, as the energy on the outside can continually flow through the inside and vice versa -- the flow is never interrupted.

Most likely, the funnel cloud in a tornado represents the flow through the center of a very active spherical torus of energy, and the rest of the sphere is not visible. The tubelike center of the spherical torus forms its rotational axis, as we have said.

This becomes an important point when we start looking at the spherical harmonics that show up in planetary energies, which we will see in later chapters. Indeed, the standard model of a planetary magnetic field shows a torus very clearly, with energy streaming out from the magnetic poles and forming a toroidal energy field around the planet itself.

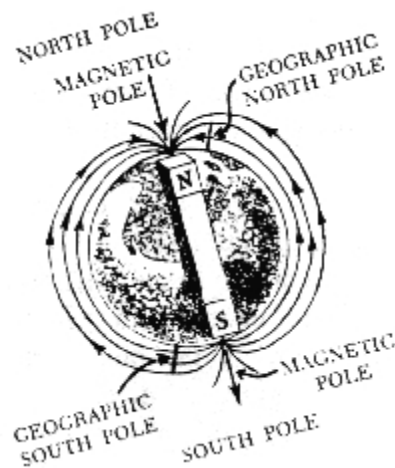

## 7.8 SEARL REVISITED

As we are looking at the fundamentals of the spherical torus or VD, we can find more evidence within the finer workings of the Searl Levity Disc, or the Searl Effect Generator (SEG.) Importantly, much of Searl's research was initially inspired by his study of Schappeller's glowing spherical magnetism.

We remember from the last chapter that the center of Searl's design involved three concentric magnetic rings, each of which were surrounded by a series of magnetic rollers. In Chapter 55 of his mammoth Internet work *Impossible Correspondence*, which cross-references our work in a number of places, researcher Robert Grace reveals the following:

"John [Searl's] concepts are quite simple. What the rings and rollers represent is a cross-section of a complete system shaped like a sphere with a hole in the middle or a torus.

The reason that the rings do not take the shape of a sphere is because the rollers, if they were curved, could not possibly revolve, hence limiting them to a flat-plane 3-tiered diameter across an imaginary sphere.

[Note: As part of the design, each of the rollers revolves around its own axis at the same time that it revolves around the central rings.]

The Searl system strips electrons off the atoms (ions) that are drawn into the center of the torus and accelerates them to the outer rim where they are picked up by coils as electricity."

So, the true nature of what Searl had accomplished now comes into view. The rotating magnetic rings and rollers create the middle framework for a series of fields that actually form a vacuum domain or spherical torus.

Obviously, as this is such a harmonic shape, it draws in a great deal of aetheric energy, thus significantly deflecting gravity enough to neutralize its mass. The spinning motion of the magnetic rollers causes measurable aetheric / electromagnetic energy to "spray " outward in exactly the same fashion as DePalma's homopolar N-Machine that we discussed in previous chapters.

### **7.9 ROSCHIN AND GODIN: SEARL EFFECT VERIFIED**

Furthermore, an article that was briefly posted on Dr. Steven Greer's CSETI website beginning on Aug. 15, 2000 reveals that two Russian scientists, V.V. Roschin and S.M. Godin, have achieved partial but highly significant success in replicating Searl's results in the laboratory.

Their experimental setup, though only consisting of one ring and one set of rollers as seen in the first image below, behaved in a similar manner as did Dr. Searl's. The second image below shows a side view of the entire device, allowing the reader to see the complete structure that allowed the rings to rotate.

After the rotors reached 200 revolutions per minute, the weight of the setup began steadily decreasing and it would begin "self-accelerating, " meaning that it would begin increasing its speed of rotation even though no extra power was being put into it.

Once the rate of rotation reached the critical speed of 550 rpm that Dr. Searl had originally determined, the device would generate a "back current " of energy that was greater than what it took to run it, and the weight of the device would quickly change to a mere 35 percent of its initial value.

The researchers also stated that, based on their knowledge of the technical aspects of Dr. Searl's research, the following would also be true:

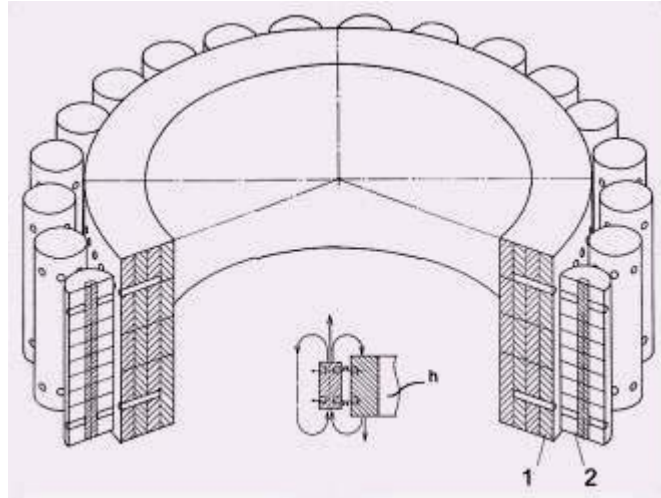

The most interesting region (i.e. the total defeating of gravity to produce levitation) lies above the critical area of 550 rpm, but due to a number of circumstances the implementation of such research was not possible. [Note: As one example, their setup was not constructed to facilitate the levitation of the device itself.]

[Note: In this and following excerpts, we have corrected basic English grammatical errors to make the text easier to understand. Unfortunately the writing style is a bit complex, so the reader will probably be required to read the article carefully more than once in order to “get it. ”]

The experiment also showed that a VD or spherical torus of ionizing radiation was visible:

Other interesting effects include the work of the converter in a dark room when corona discharges are observed around the converter’s rotor, which are seen as a blue-pink glowing luminescence with a characteristic ozone smell. The cloud of ionization covers the area of the stator and rotor and has an accordingly toroidal form.

Furthermore, there were discrete changes in both the magnetic and temperature readings in the room where the experiment was conducted. From the description, we are led to believe that a series of concentric VDs, or toroidal spheres of increased aetheric / magnetic energy formed around the device (which they here refer to as a converter) while it was in motion:

We noticed and measured an abnormal permanent magnetic field around the converter within a radius of 15 meters. Zones of an increased intensity of magnetic flux 0.05T located concentrically from the center of the installation were detected. The direction of the magnetic field vector [or flow] in these walls [of energy] coincided with the direction [that the rollers were traveling in.]

The structure of these zones reminded [one of the] circles on water [that form] from a thrown stone. [Note: Obviously we know that these are spherical, toroidal zones.] Between these zones a portable

magnetometer, which used the Hall's sensor as a sensitive element, did not register any abnormal magnetic fields.

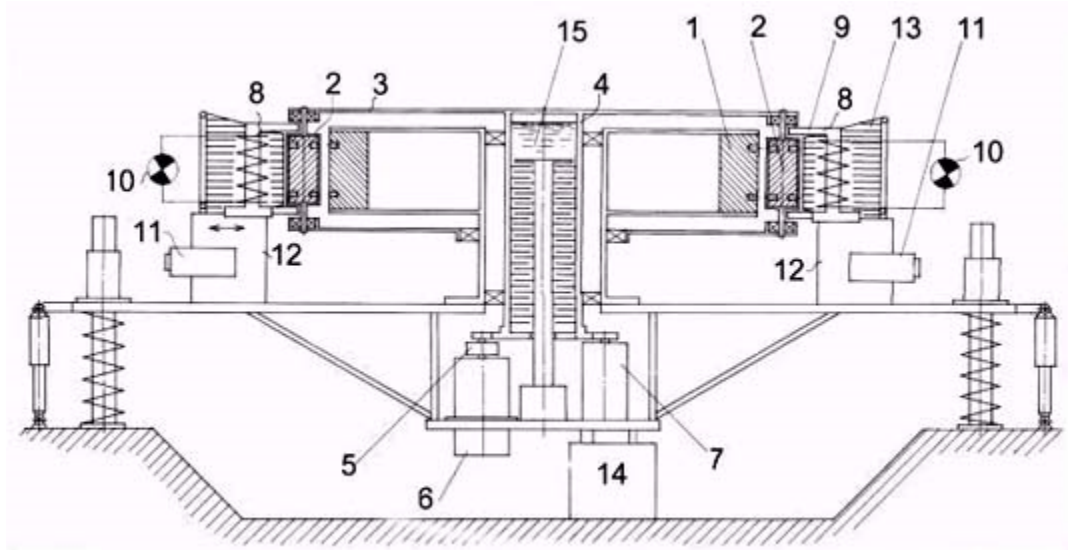

The layers [where] an increased [magnetic] intensity [is measured] are distributed practically without losses up to a distance of about 15 meters from the center of the converter, and quickly decrease at the border of this zone.

The thickness of each [magnetic] layer is about 5-8 cm. The border of each layer has a sharp shape, the distance between the layers is about 50-60 cm and it slightly accrues when moving from the center of the converter.

A steady picture of this field was observed as well at a height of 6m above the installation (on the second floor above the lab.) Above the second floor the measurements were not carried out. [Note: Previously we were told that the height of the ceiling in the experimental room was three meters.]

An abnormal fall of temperature in direct affinity with the converter was also found. While the common temperature background in the laboratory was +22 degrees C (+ 2 degrees C) a fall of temperature equal to 6-8 degrees C was noticed [in the laboratory when the device ran.] The same phenomenon was observed in the vertical magnetic walls [of energy] as well.

The measurements of temperature inside the magnetic walls were carried out with an ordinary alcohol thermometer with an inertia of indication of about 1.5 min. In the magnetic walls the temperature changes can be distinctly observed even by hand.

The hand, when placed into this magnetic wall [of energy,] feels real cold at once. A similar picture was observed at the height above the installation, i.e. on the second floor of the laboratory as well, despite the ferro-concrete blocking of the ceiling.

As of November 2007, as we update this book for our Divine Cosmos website, we've heard from the Searl camp that there is a problem with Roschin and Godin's design. Their rollers were pieced together with slices of magnets going cross-wise to the original polarity.

Apparently, the gravitational forces tear apart the pieced-together magnetic rollers and destroy the machine before it can reach a sustainable lift speed. Searl's original design introduced the magnetic 'cross' pattern directly into the magnets themselves when they were being manufactured.

### 7.10 VDs, HEALING AND THE SOUL

Obviously, these intriguing results suggest that a nested series of VDs or spherical harmonics are being formed around the device as it functions, and that these spherical "walls" represent areas where aetheric energy is directly bleeding into the room, leading to an increase in magnetism and a decrease of temperature.

The potential uses of this technology for healing purposes shouldn't be overlooked at this point, either. An [article from the West Australian newspaper](#) on August 7, 1995, linked at , said the following:

A 45-litre drum of burning oil exploded in [Searl's] face a few years ago and doctors told him he would be disfigured for life. But sitting in his SEG-powered home for two weeks, he said his wounds healed...

The SEG would also help combat asthma, bronchitis, hay fever and lung complaints. "You don't feel like you are breathing but drinking fresh spring water," he said. "That's because you have more oxygen available."

This report could not be studied scientifically by Roschin and Godin in their experiment. However, the Roschin-Godin study represents the first time that Searl's results have been independently confirmed by an outside laboratory, thus dramatically increasing the reputability of his findings.

Those who choose to be skeptical and dismiss these results are simply too stubborn to see the simple truth - anti-gravity and free energy is a reality, and with the arrival of the Internet and books like this one, it is only a matter of time before these technologies are widely known and implemented.

And as we shall see as we go along, the spherical structure of the VD will be seen as the "missing link" to unify the Cosmos at every level, from the smallest quantum process to the macroscopic structure of the Universal Being itself.

The VD is a reflection of the Ultimate Being in "physical" form. It is also the "shape" of our soul - our true energy bodies.

In the next chapter, our discussion of spherical harmonics and energy processes will continue, as we bring in the work of John Keely.

We will show more evidence of the importance of the sphere as the shape of “balance ” in the aether, as well as the connections between the aether, the sphere and the vibrations of sound. We will also see how sound can be utilized to produce anti-gravity as well.

## **7.11 RECAP**

**7.1** The work of Karl Schappeller provided the initial inspiration for Dr. Searl. He explained that strong magnetic fields can cause the aether vacuum to emerge as a visible form. The phenomenon of “ball lightning ” shows this in action.

**7.2** Light and Love and the Sphere are all interchangeable definitions of aetheric energy that is in unity with Oneness.

**7.3** Schappeller was able to engineer a spherical ball of “glowing magnetism ” in the laboratory with his dynamagnetic generator.

**7.4** Dr. Dmitriev et al. labeled this spherical “glowing magnetism ” as a “vacuum domain ” or VD. Furthermore, his team used equations to show that gravity waves are automatically transformed into electromagnetic waves inside the VD, and these waves are then directly visible to us as light.

**7.4.1** The nine essential properties of vacuum domains are: ability to penetrate solid matter, light absorption and / or emission, the powering down of electronic devices, creation of measurable magnetic fields, distortions of gravitational fields to increase or decrease objects’ weight, constant inner rotation leading to rotation of air and dust inside of themselves, explosions that do not necessarily change their size, possession a definite geometric form such as a sphere or “ellipsoid, ” and increases in their appearances during years of peak solar activity.

**7.4.2** Ten different sorts of anomalous phenomena that appear to be directly associated with VDs are: ball lightning, NSLFs or “plasmoids, ” poltergeists, tornadoes, radar angels, small comets or “atmospheric holes, ” ionospheric and atmospheric explosions, lithospheric “pipe ” explosions, “sprites / elves / jets ” and luminescences associated with earthquake and volcano activity.

**7.4.3** Mr. Martyn Stubbs’ rigorous documentation of “NASA UFOs ” appears to be an observation of VDs in space. The spherical shape, central hole and spiraling energy emissions from the central hole are all clearly visible on film.

This also gives us a method of understanding why our scientists have observed “atmospheric holes ” occurring in the ultraviolet spectrum of our ionosphere appearing 20 times each second. The VDs are created in the Sun, travel through space on the “solar wind ” and later strike the Earth, creating the holes.

**7.5** The spherical fields of vacuum domains can be seen to form anomalous structures in space, such as the dumbbell shape of the nebulae Eta Carinae.

**7.6** Charles Cagle demonstrated the idea that “particles ” at the subatomic level are actually VDs as well, which he named “electromagnetotoroids. ” From his understanding, workable free energy technologies have been devised. This brings us closer to a true “unified field ” theory that shows how these VD formations exist at every level of size and complexity in the Universe.

**7.7** The torus is a sphere with a hole in the middle, forming a donut shape. This is the true form of the VD, and explains the structure of the Earth's magnetic field as well as the structure of the funnel cloud that makes the tornado. The "hole " in the sphere is what creates an axis that allows it to rotate.

**7.8** Robert Grace reveals that what the rings and rollers represent in the Searl Effect Generator is a cross-section of a complete system shaped like a sphere with a hole in the middle or a torus. By creating this cross-section of the VD with rotating magnets, Searl was able to replicate the anti-gravitational effects of the VD and use them to levitate the craft itself.

**7.9** Russian scientists Roschin and Godin were able to replicate Searl's results. Though their device was not physically built to levitate, it clearly would have if they did not use mechanical brakes to stop it, as it went into a self-accelerating mode after crossing the critical threshold of 550 revolutions per minute.

Most interestingly, when the device was powered a series of spherical energy zones were created around it, and "the structure of these zones reminded [one of the] circles on water [that form] from a thrown stone. " Within these zones, the magnetic fields increased and the temperature decreased.

The Roschin-Godin replication cannot reach full lifting power, apparently, because the strong gravitational field tears apart the pieced-together magnetic rollers.

**7.10** Dr. Searl's research associated the aetheric energy of the VD with an increased speed of healing. We suggest that the VD is actually the shape of the Ultimate Being, or God, as well as the shape of the soul as it is expressed in our different energy bodies.

## CHAPTER 08: KEELY AND THE PHYSICS OF VIBRATION

[Tweet](#)



John Ernst Worrell Keely, 1837-1898

## **8.1 VACUUM DOMAINS = “CONSCIOUSNESS UNITS ”**

In the last chapter we showed how the energy of the aether can directly emerge into our physical reality through what is referred to as a “vacuum domain ” or VD. This will commonly take up the form of a glowing, rotating sphere of light with a hole that passes through its center, making it look somewhat like an apple, a donut or the inside of an orange.

The technical name for this shape is a “spherical torus.” Once a VD is created, anti-gravity effects can be produced, as well as “free energy.” The VD opens a gateway for the higher-pressure aether energy to stream into our physical world, much as a hole in the side of a water tank will cause the water to come rushing out.

Gravity waves, which normally press into the earth, are absorbed and transformed into electromagnetism and visible light within these objects. Numerous observations of anomalous phenomena in the lithosphere, atmosphere and ionosphere of the Earth, as well as in free space on NASA shuttle footage, all support the existence of these VDs as a tangible reality.

Professor John Searl used these principles to create a workable anti-gravity machine, whose drive system was built with a rotating system of magnets. Later, Russian scientists Roschin and Godin replicated Searl's results independently and measured temperature drops and “spheres within spheres ” of magnetic energy that surrounded their device once it was powered up.

For our purposes in this chapter and thereafter, we will replace the unwieldy-sounding term “vacuum domains ” with the simpler and more all-inclusive term “consciousness units ” or CUs. As our discussion gradually progresses away from discussing free-energy and anti-gravity machines, we will increasingly need to support the idea that the aether is intelligent energy in the text.

If we do not see the energy of the “consciousness units ” as having all the ingredients for life, consciousness and Spirit within themselves, then we will be ill-prepared for our future chapters in this book.



## 8.2 KEELY DID IT FIRST

As we continue looking at these theories, it should be even more amusing to discover that long before Schappeller, Larson, Searl, Cagle, Nordberg or Dmitriev, another physicist had also worked with these same concepts of "vacuum domains" or "consciousness units" of spherical energy with apparently astounding levels of success, if eyewitness accounts of his inventions are indeed accurate.

This scientist was John Keely, and his work has now enjoyed such a renaissance that the [KeelyNet website](#) is at the forefront of alternative energy, aetheric science and anti-gravity research.

Furthermore, Keely was not afraid to directly connect his theories with the idea of an Ultimate Being and of the philosophy of love and light as the unifying force in the universe, then being expressed in the form of the aether energy.

John Ernst Worrell Keely was born in 1837 and died in 1898. During this time, mainstream physics still considered the aether model to be correct, as the aftereffects of the Michaelson-Morley experiment would not be fully felt until the 20th century.

Bearing all this in mind, every scientist of Keely's time naturally gravitated towards the aether model, (pun intended,) as it was in common acceptance at the time. Some of the designs were clearly flawed, as the early scientists were prone to believe that this aether was actually another form of physical matter, which it is not.

Together, these ideas were called the "material aether" theories, and they were definitely incorrect. As one example, the "flux lines" of magnetic force are not a form of physical matter; they behave more as an energy field than as a literal fluid in motion. No one will ever find a tangible "fluid" in a magnet that they can literally pour into a glass!

The energy is all around us and the magnet just focuses it so that it flows in one direction. Once modern quantum mechanics and relativity took off in the early 20th century, the scientific mainstream had discarded the aether theories completely, even though they were ultimately not "wrong," as we have already shown.

## 8.3 THREE MAIN AETHERIC FORCES: PUSH, PULL AND STABILIZE

Keely's biggest contributions to our "consciousness unit" theories relate to how the aether creates and maintains a CU. The first principle is that within each CU or luminous sphere of aether, there are three forces -- the contracting force that we call gravity, an out-pressing force that we might call "levity" or anti-gravity and the stabilizing force that balances out the first two.

These ideas are simply the end products of studying and observing the behaviors of vibration. So, if you picture a spherical balloon that is constantly inflating and deflating with air, you can see this in action:

1. Each contraction or shrinking of the balloon would be what Keely called the "tractor" force, akin to gravity. Outside air pressure contracts the balloon towards the center.
2. Each expansion of the balloon would be the "pressor" force, where the center pushes outward against the surrounding air pressure, akin to "levity" or anti-gravity.
3. A stabilizing force not unlike the balloon skin itself, which balances out and equalizes the vibrations, would be called the "dominant."

### 8.3.1 GRAVITY REDEFINED AS A PUSH-PULL EFFECT BETWEEN TWO FORCES

Here, it is very important for us to remember that there are actually two different forces working together in the earth to create what we measure as gravity. In bluntly simple terms, gravity is not just “down;” it is the natural balance between the forces of “down ” and “up. ”

So, using Keely’s terminology, there is the tractor force that moves towards the core, and there is the pressor force that moves away from the core. Therefore,

What we interpret as “gravity ” is the leftover force once the “up ” and “down ” energy movements have canceled each other out. Keely calls this point of balance the “dominant. ”

An easy way to visualize this is with a tug-of-war game, where two equal-sized teams of people pull on a long, thick rope as hard as they can. In the middle of the rope someone will tie a bright marker ribbon, and the objective is for one group to pull the rope far enough in their direction that the ribbon crosses a line that has been drawn on the ground.

Once either team gets the ribbon to cross the line on their side, it means that they have pulled the other side far enough along to be considered the stronger team.

If we look at the battle between gravity and levity as a different sort of game where the two “teams ” are pushing towards each other instead of pulling away from each other, then gravity, the force that presses down, is always “winning ” over levity by a set, balanced amount, which we now know as the “gravity constant. ”

### 8.3.2 OBSERVATIONAL PROOF OF PUSH-PULL EFFECT OF GRAVITY

Most people never consider that we see proof of this balanced interplay between gravity and levity every day. Think about conventional ideas of gravity for a moment; it is believed to be a force that causes two objects to be attracted to each other.

If this is the only force that exists, then we should expect that when two objects get close enough to experience gravitational attraction to each other, they will literally come into contact with each other.

However, all you need to do is look up at the Moon on any given night, and you can see the proof that this is not what happens! We know that the Moon has enough of a gravitational pull that it can cause the oceans to move, forming the tides on the Earth, and yet it always maintains a perfect distance from us with an ongoing and even orbital motion. To put it bluntly,

**If there wasn’t a constant push-pull of gravity and levity moving between the Earth and the Moon and balancing their positions, they would have crashed into each other long ago!**

Furthermore, recent advances in “Big Bang ” cosmology theory have essentially come to the irrefutable conclusion that levity must push between large-scale structures in the Universe in order for them to be able to repel each other without colliding.

So here again, we have an example of how thoughts are changing, but this line of reasoning has not yet worked its way back to our own local area and theories of Earth’s gravity.

For another piece of proof, we can again cite the work of Richard Pasichnyk on his *Living Cosmos* website at <http://www.livingcosmos.com/earth.htm>, page 12, to make the point yet again:

Downward from the Earth’s surface, [gravity’s] primary differentiation with depth is accompanied by the progressive decline to zero of the force of gravity at the center of the Earth.

Normal gravitational force, downwardly directed, is replaced by a reversed upwardly directed force at depths greater than 2,700 kilometers (1,678 miles), which would pull matter away from the core. This is especially true because the core is now known to be much hotter than previously thought.

This is why research involving deep mines and boreholes has shown different values for gravity with depth. In fact, a person deep within a mine weighs less than that same person on a mountain top.

Moreover, those scientists studying the phenomena have called for a new model of the Earth, but long-held theories are not easily dismissed. As a result, the phenomena has been virtually ignored.

#### **8.4 ABSORBING GRAVITY WITHOUT ABSORBING LEVITY**

So, if this push and pull tug-of-war game is constantly being fought between gravity and levity, then gravity is always slightly winning the game on the Earth’s surface. However, since the two forces are actually very close to being in an exact balance with each other, if you can somehow absorb some of the downward-contracting gravitational force without absorbing the up-pressing “levity ” force, then the Earth’s levity will naturally push you away from its surface, thus creating anti-gravity.

Now at first, the idea of being able to absorb one force without absorbing the other doesn’t seem possible. However, in Dmitriev et al.’s scientific model, we know that a “vacuum domain ” or consciousness unit is actively absorbing gravitational energy and transforming it into electromagnetic energy and Light, since all these fields are different forms of the aether in motion.

We are also told in Dmitriev et al.’s study that a “vacuum domain ” has a definite, polarized “direction ” for its gravitational effects; one end of the tube that runs through the center of the sphere will increase the weight of objects and one end will decrease the weight of objects.

This is not the way that gravity functions on Earth, obviously. The Earth has a magnetic field that is shaped like a spherical torus, but gravity moves uniformly throughout its surface; nothing will appear heavier on the north or south pole than it will on the rest of the Earth.

However, when we create a “vacuum domain ” as Dr. Dmitriev et al. define it, we have an area where the electromagnetic movement and gravitational movement both flow together, and this is very different from what we see on the planets; we can indeed have a “north gravitational pole ” and a “south gravitational pole. ”

In everyday scientific observations, gravity is much weaker than electromagnetism by an order of 40 magnitudes, but inside a VD all the rules have changed and the power to absorb and / or repel this energy changes dramatically. So for our purposes, we will refer to these polarized formations as “polarized CUs, ” since other CUs, such as those surrounding the planets, do not possess this unique property.

So, when we add in the fact that ‘gravitational energy’ is a balance between two forces, then we may very well be able to absorb the energy of gravity more than levity, or vice versa. As we shall see in the next few paragraphs, the direction that the outside of the polarized CU is rolling will determine which force it absorbs more of.

If this seems hard to visualize, just look back to the idea of water going down the drain in your sink. If the flow in the polarized CU is moving from the north pole down to the south pole, then the “drain ” will naturally absorb more of the downward-flowing gravity force, transforming it into electromagnetic energy and visible light.

At the south pole there is another “drain ” that will simultaneously push away from the upward-flowing levity force. And with this setup, you can build an anti-gravity machine!

But wait, you say. How do we get this “gravity drain ” to move through a solid machine? Wouldn’t we need to build a hole in the middle so that our spherical energy field could freely flow through the device? Would everyone’s hovercraft have to look like a donut? How could the spherical energy circulate through it otherwise?

For the answer, we go back to Dr. Dmitriev et al.’s list of the nine properties of vacuum domains. If we remember, the very first property of a “vacuum domain ” is that it fully penetrates through the matter it surrounds.

This is exactly what is occurring in the Searl Levity Disc. You do not need to build a hole in the middle of your machine, because the middle of the spherical torus will automatically pass right through the machine! These forces are not hindered in their movement by the presence of matter, but blow right through it just as gravity moves through the Earth.

So then, as the center of the torus passes through the matter that makes up the center of the machine, the entire torus rolls over itself inside-out like a smoke ring, in a constant flowing motion.

It can only roll in one of two ways: either rolling “downwards ” through its center from the north pole to the south pole, like water pouring down a drain, or “upwards ” through its center from south to north, like water spraying up through a fountain.

The direction of the rolling movement will depend on how the polarized CU was initially formed, so different machines could be built for the two different directions. So, to summarize this point, we can say that:

The total balance between gravity and levity forces acting on a polarized CU will increase or decrease depending on which direction its energy is “rolling, ” either “up ” or “down. ”

We will explain how this is possible so that it is absolutely clear for those who are interested. First of all, let’s not forget that the outer surface of the torus expands and contracts in size. If you draw two dots on an inflated balloon

and measure the space between them, then deflate the balloon and measure the space between the dots again, it will obviously be smaller the second time.

Similarly, on the outside of the sphere the energy is fully stretched out and relaxed, whereas once it moves through the middle of the sphere it becomes compressed, and thereby more energetic. This means that the greatest force and fastest movement is in the tubelike center of the torus. This is no different than the Earth's elliptical orbit around the Sun.

When the Earth is at its furthest point, known as "aphelion," it moves more slowly, but as it approaches "perihelion," when it is closest to the Sun, it moves much more quickly. This speeding-up effect is often used to increase the velocity of satellites by moving them close to a planet or moon, and scientists refer to it as the "slingshot effect."

A very dramatic portrayal of this process can be seen in Arthur C. Clarke's movie "2010," with American and Russian scientists onboard a Russian ship called the Leonov.

On Earth, the best physical example that we have for this increased movement in the center of a polarized CU is in the case of a tornado. The central "funnel cloud" flows like a raging whirlpool, because the energetic surface of the CU is being compressed as it moves through the "tube."

The outside sphere, which is usually not even visible, flows much more slowly, because its surface is fully expanded. This is no different than the slow-moving waters that always surround a whirlpool in the center, which you can see every time you drain water out of the bathtub or sink.

[This can also be seen in the activity of the Sun's magnetic field, known to us as the heliosphere. NASA's Ulysses space probe determined that energy moves much more quickly above and below the Sun's poles than it does in the surrounding areas.]

In a tornado, the funnel cloud is usually seen to "touch down" from the sky. This means that the rotational movement is traveling downwards in the center, and obviously upwards around the outside of the spherical energy field that forms around it, which is typically not visible.

So, as the direction of energy flow in the torus moves downward to the center, the downward-moving gravitational force will be captured and drawn into the glowing, energetic core of the tornado and transformed into energy and light, as Dr. Dmitriev et al.'s equations and Keely's studies project.

Then at this point, the upward-pressing "levity" force from the Earth can supercede the force of gravity, and objects on the Earth will be pushed away from the Earth's surface into the tornado. No vacuum is required within the tornado itself, as was observed in the 1951 case from Texas, as this is an energetic process.

The tornado's power for levitation has absolutely nothing to do with air pressure or suction, and just to make the point abundantly clear we will cover Dr. Dmitriev's surprising research on tornadoes more fully in our next chapter.

So, if we reverse this process so that the field of the spherical torus is flowing upwards through the center, then it will suck more of the "levity" force into itself and thus cause the downward-moving gravity to become even more effective on the object, causing it to appear to weigh more. Understanding what direction the spherical torus needs to flow in order to produce anti-gravity will be important for those who will use these concepts to build working models.

## 8.5 ZERO-SPIN ENERGY TRANSFER

Another important observation from Dr. Richard LeFors Clark is that in the center of any magnetic field, there is a point of "zero-spin energy transfer." In order for the entire outside of the field to rotate, it has to change direction in the center.

So, this would mean that if you have a clockwise vortex rotation at the North Pole, you will have a counterclockwise rotation at the South Pole. In the middle there is no rotation at all. This area of zero-spin energy transfer is also referred to as a "Bloch Wall," and Dr. LeFors Clark associates it with anti-gravity effects.

This can be seen in the next diagram, co-opted from Dr. LeFors Clark, which shows how the rotational change occurs inside a bar magnet. We should also remember here that this diagram does not show us the normal spherical torus field that surrounds the bar magnet, only a tracing of the rotational movement inside.

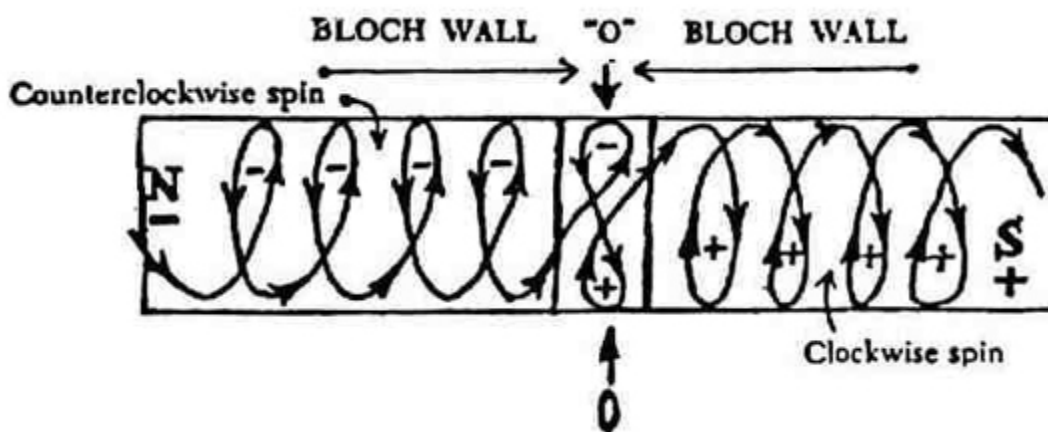

Dr. Richard LeFors Clark's diagram of the rotational change in a magnetic field.

With our understanding of this principle, we are better equipped to see the importance of the exact center of any given consciousness unit, polarized or otherwise. This is an area where there is no rotational movement and tremendous energy. Keely also discovered this phenomenon and named it the "neutral center."

## 8.6 NEUTRAL CENTER: THE SEAT OF THE ONENESS

The second most important principle in Keely's model is that of the "neutral center." This neutral center will always be at the exact center of any CU or harmonic sphere of aether / Light. Think again to the 1951 observation of a glowing mass in the center of the tornado column to understand why the center of the CU is so important.

Keely wrote very eloquently about how the true core of this "neutral center" is unthinkableably small, but yet still serves as the unified, ultimate center of all the aetheric forces at work. All instreaming aether, such as in the case of Earth's gravity, would compress into the neutral center, where the pressures would have to be simply unimaginable.

However, in that same spot the overall gravity force would be very low, since there would be no place else for the two opposing forces to "move" to when they are already at the point of perfect balance. So, at that point, even though the pressure is very high, the gravitational and energetic forces are perfectly neutral, hence the name "neutral center."

In Keely's model, this Center would represent the true Oneness of God, the unity of all vibrations. Every CU throughout the entire Universe, (including the hierarchy of human spiritual bodies,) is connected to every other by this Center, in which there is no space and no time, just Oneness.

On the metaphysical or spiritual level, we are asked to visualize that all matter, all aether, all Love, all Light, all Life, all the Universe ultimately emanates from this one single point of energy, which can be called God or The One. Furthermore, space is the illusion that is formed as aetheric energy flows into and out of this center, when in reality the center is everywhere and nowhere at the same time!

Confusing, right? Some of these concepts can require a great deal of mental flexibility. Even though this is obviously not the easiest thing to visualize, we can make it easier to see. Imagine that all of the visible Universe is arranged on the outside skin of a balloon, and then you suck all the air out of the balloon.

Once the air is gone, let's say that the entire outside surface of the balloon shrinks up into a single, tiny point. So, if everything on the balloon's surface still "exists" somehow, then what do you have left at that point?

*The entire Universe then exists in that One Point in the center...*

...only in that moment it was entirely "infolded!"

When you blow up the balloon again,

**The entire universe then unfolds from that One Point in the center to form the "illusion" of space and time.**

This might seem preposterous on one level, but sources such as the Seth Material insist that this is exactly how our multidimensional universe actually functions. However, for our purposes the energy is constantly pulsating into and out of the center so quickly that we could never normally detect the times when the energy of the Universe is totally focused in the center; it appears to be simultaneous, where all vibrations exist at once.

Some people have had the experience of moving into this Center, which the Ra group refers to as "intelligent infinity." It is always seen as a blinding white light and a feeling of vast, unspeakable joy. Everyone who sees it immediately recognizes it as their true, ultimate Home, and in certain cases they have a hard time leaving it behind to return to their "normal" existence here on Earth.

Now again, any time that a spherical energy field is breathing in and out from the center point in our universe, we have a "consciousness unit." As we go on we'll be explaining that nothing else BUT "consciousness units" exist, in various forms, subatomic through cosmic. Furthermore,

The energy of all CUs in the universe is constantly compressing into and back out of this single "point" of Oneness at a speed that is much faster than our physical bodies are capable of perceiving.

At that Center point, there is no time, no space, no movement.

So, as the energy flows into the center in a spherical "consciousness unit" such as in the case of a tornado or ball lightning, so too does it radiate back out of the center. This is just like a continuous "breathing" motion.

If we could slow the energy movement down to a sufficient degree in a polarized CU that is flowing from north to south, then we would see pulses of energy emerge from the center, flow down the tube, out the south pole, curve over the bottom and then the outside of the sphere, then over the top and down again into the north pole of the tube to be reabsorbed into the Center.

(And as we shall see in future chapters, the surface of the Sun shows incontrovertible evidence of a heaving movement, where its surface is noticeably increasing and decreasing in size over a 160-minute period of time.)

## **8.7 SUMMARY OF "TRACTOR", "PRESSOR" AND "DOMINANT" FORCES**

So, to summarize these points and tie them back in to Keely's three major forces, we can say that:

Energy force, such as gravity, streams into an object as the "tractor" force and upholds its molecular structure as it moves through.

Once the energy force moves into the neutral Center it merges back into the Oneness and is transformed.

Then, that transformed energy moves away from the Center in the opposite direction, thus producing the "pressor" or out-pushing force. This is also required to nourish and support the molecular structures with energy.

As the two movements naturally balance in the "dominant" or stabilizing force, this completes the cycle of matter creation or the "breath of life."

At this point, let's not forget that Keely also used a spherical torus as the fundamental model for aetheric activity, just as we demonstrated in the last chapter.

So, once again we have a case where the lost secrets of the Universe were discovered and harnessed, only to be lost yet again so that others must rediscover them later on. And indeed, after his death in 1898, a supporter of Keely's work said that it would take 100 years before someone would come along and be able to understand what he had done.



## 8.8 USING SOUND TO ALTER THE PROPERTIES OF MASS

So, Keely could clearly see that vibration was the underlying key to all physical matter. He realized that even though this vibration occurred in a form of energy that we couldn't physically see, it could still be measured.

Keely discovered something else that is so absurdly simple that most readers will probably be quite surprised that they hadn't thought of it by this point. Without using the complex magnetic rings and rollers of Dr. Searl, Keely was able to create an energetic CU around an object with sound frequencies! Here we will explain how it works:

1. A physical object is made from the flow of aether.
2. By vibrating the object at a very pure sound frequency, you automatically will vibrate the aether that creates it as well.
3. Once you set up a vibration in the aether, you can focus and direct it just as Dr. DePalma and Dr. Searl did with magnetism and rotation. The principle is the same: you are causing the aether to flow in a specific direction that is different from its natural "balanced" state.
4. By concentrating sound pulses directly into the center of the object, "ripples" or "waves" of vibration are created through the object itself as well as in the aether that forms it.
5. When these vibrations reach the center, they will collide into each other and then be forced to spray away from the center, forming Keely's "pressor" waves.
6. Once this "directional" flow of aether begins, a gateway is formed where the high pressure of the aether vibrations will bleed through into physical form as we have described above.
7. This "bleed through" will then create a "vacuum domain" or what we are now calling a "consciousness unit," forming all nine of the properties in Dr. Dmitriev's list including anti-gravity and electromagnetic fields.
8. Thus, you get "energy" from "sound" by forming a bridge that allows the massive energy of the aether to flow into our physical reality. (And we remember that the volume of this energy in a single light bulb is strong enough to boil all the world's oceans.)

Keely knew that gravity was simply the large-scale push-pull motion of aether, and matter is also made of aether that naturally vibrates at a certain frequency.

If he could use a very pure resonance to cause an object to vibrate in perfect harmony, then it was possible to cause a current of aetheric energy to flow around the object, which would allow it to either increase or decrease the effects of gravity on it, as we have described.

But wait, you say! Gravity isn't just a force that needs to be overcome, it is also our source for the energy of the Universe that all physical matter must draw off of to sustain itself! So if you cut off the effect of gravity, wouldn't you also cut off the lifeblood of any matter inside, thus causing it to either dissolve or explode? In some cases this might happen, but if you design your anti-gravity system well, it will not. Here's the explanation:

Inside the spherical field of the CU, the matter does not collapse, even though it is "cut off" from the normal flow of gravitational energy from the Earth that surrounds it on the outside.

Remember that by Dr. Dmitriev et al.'s definition, a polarized CU forms its OWN gravitational field and "breathes" into and out of the center point in its own right, in exactly the same way that the Earth does with its gravitational field.

Therefore, the matter inside the sphere of the CU is now being supported and replenished by the sphere itself, not the energy outside of it.

Inside the spherical energy field, therefore, you are only affected by the natural gravitation and inertia of the CU itself. This means that you could effortlessly move through space at high speeds and make sharp turns without hurting yourself.

Furthermore, just as we explained above, Keely could use the same principles of the polarized "consciousness unit " to make an object's weight much heavier by causing it to flow "upwards " and absorb more of the levity force.

Keely's most impressive accomplishment in these areas was the production of a flying craft using these principles. This is covered in an article on KeelyNet by Dan Davidson. The article, in turn, is excerpted from his book *A Breakthrough to New Free Energy Sources*:

John W. Keely, discoverer of Sympathetic Vibratory Physics, found a means of negating the effect of gravity as well as developing a form of propulsion.

From 1888 to 1893, Keely worked on developing his system of "Aerial Navigation." The first successful test was in 1893 which led the way to the construction of an aerial craft.

In 1896, Mr. Keely had so perfected his system that he arranged to give a demonstration of the aerial craft to the United States War Department. In attendance at the demonstration were a number of invited members of the press.

Descriptions of the craft state that it was a circular platform roughly 6 feet in diameter. On this platform was mounted a small stool set before a keyboard. The keyboard was attached to numerous tuned resonance plates and vibratory mechanisms.

[Note: We can assume that Keely had some mechanical process, possibly electrical, for keeping the vibratory mechanisms and tuned plates going. This appears to be what created the "polarized field" indicated in the next paragraph below.]

Mr. Keely explained that these plates would cause the craft to rise and float above the ground when subjected to a polarized field which would generate a "negative attraction." When the effect was produced, the craft would come under the influence of [what Keely referred to as] the "etheric polar current."

The controlling mechanism consisted of a row of 100 vibratory bars representing the enharmonic and diatonic scales. When half of the bars were damped the craft would move at 500 miles per hour. If all the bars were damped, gravity would resume control and the craft would settle to the earth.

[Note: Obviously these bars are not the main generators of the sound vibrations; they only change the way the vibrations are flowing through the device by their resonance. Dampening certain bars allowed Keely to make slight changes in the direction of the flow in the CU that was surrounding the craft, thus changing how the craft traveled through Earth's gravity.]

There were no moving parts in the ship's propelling mechanism. [Note: However, it is still producing a “polarized field ” somehow to create the main vibrations that allow it to levitate.]

It was unaffected by weather and could rise above any storm. The instrument for guiding the airship was distinctly different from the propelling feature. By damping out certain specific notes, Keely could cause the airship to accelerate to any desired speed.

The experiment was carried out in an open field with observers from the War Department and news media. The ship was said to have accelerated from 0 to 500 miles per hour within a few seconds.

Most astounding was the apparent total lack of acceleration effects to Mr. Keely as he sat on the stool before the keyboard, controlling the airship.

Although the government officials were impressed, they stated [that] they could see no use for such a complex device and so did not pursue the matter further. (Remember [that] the Wright Brothers did not demonstrate their airplane at Kittyhawk, NC until December 17, 1903; seven years later!)

When we see that Keely was unaffected by the "g-forces" of inertia as the craft flew, we should immediately be aware of how this would occur. The area around the craft itself was not being affected by the aether as an ordinary object would be.

Thus, as the craft sped through the air, it produced its own energy field that counteracted the natural pressure of the aether around it. Keely felt no acceleration because he was trapped within the spherical bubble of energy that prevented the aether pressure from changing inside. Similarly, many UFO sightings have reported split-second 90-degree turns at speeds so fast that conventional g-forces would completely destroy the body of any pilot inside.

In the rest of this chapter, we will detail other examples of sound-induced levitation that will help make the whole idea "feel" more possible to us, instead of allowing it to simply appear to be “too good to be true. ” And for those who are interested, there is quite a bit more to learn about Keely's work on the KeelyNet website, and the book *Physics of Love* by Dale Pond is a comprehensive introduction to Keely's work and the harmonic physics of sound, light and geometry that go along with it.

## **8.9 TIBETAN ACOUSTIC LEVITATION**

A similar usage of sound to produce levitation is the now-infamous story of Tibetan Acoustic Levitation. Various tidbits of the story emerge repeatedly in the discussion rooms and articles on free energy and UFO websites, however the best treatment of this story that we have found is in an article by Bruce Cathie in the book *Anti-Gravity and the World Grid*.

The beginning of the report is transcribed from a German magazine article that was translated into English; and we begin at the point where the translated article starts.

We know from the priests of the far east that they were able to lift heavy boulders up high mountains with the help of groups of various sounds... the knowledge of the various vibrations in the audio range

demonstrates to a scientist of physics that a vibrating and condensed sound field can nullify the power of gravitation.

Swedish engineer Olaf Alexanderson wrote about this phenomenon in the publication, Implosion No. 13.

The following report is based on observations which were made only 20 years ago in Tibet. I have this report from civil engineer and flight manager Henry Kjelson, a friend of mine. He later on included this report in his book, *The Lost Techniques*. This is his report:

A Swedish doctor, Dr. Jarl, a friend of Kjelson's, studied at Oxford. During those times he became friends with a young Tibetan student. A couple of years later in 1939, Dr. Jarl made a journey to Egypt for the English Scientific Society. There he was seen by a messenger of his Tibetan friend, and urgently requested to come to Tibet to treat a high Lama.

After Dr. Jarl got the leave he followed the messenger and arrived after a long journey by plane and Yak caravans at the monastery, where the old Lama and his friend who was now holding a high position were now living.

Dr. Jarl stayed there for some time, and because of his friendship with the Tibetans he learned a lot of things that other foreigners had no chance to hear about or observe.

One day his friend took him to a place in the neighborhood of the monastery and showed him a sloping meadow which was surrounded in the northwest by high cliffs. In one of the rock walls, at a height of about 250 meters, was a big hole which looked like the entrance to a cave.

In front of this hole there was a platform on which the monks were building a rock wall. The only access to this platform was from the top of the cliff and the monks lowered themselves down with the help of ropes.

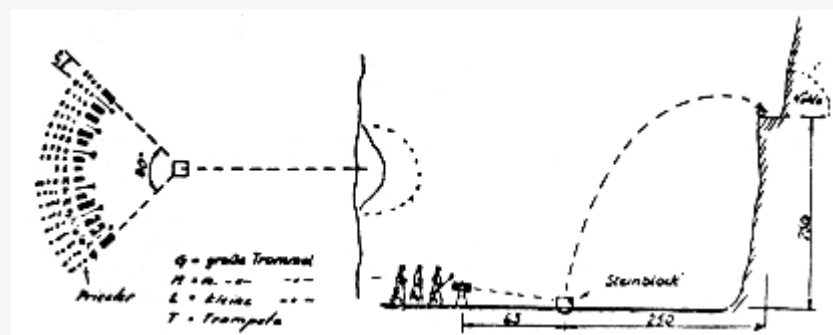

In the middle of the meadow, about 250 meters from the cliff, was a polished slab of rock with a bowl-like cavity in the center. [Note: This is part of how the sound resonance was focused on the object.]

The bowl had a diameter of one meter and a depth of 15 centimeters. A block of stone was maneuvered into this cavity by Yak oxen. The block was one meter wide and one and one-half meters long.

Then 19 musical instruments were set in an arc of 90 degrees at a distance of 63 meters from the stone slab. The radius of 63 meters was measured out accurately. The musical instruments consisted of 13 drums and six trumpets. (Ragdons).

[Note: At this point the exact measurements of all the instruments are given in detail, which we have omitted here for brevity, as these measurements are discussed further in the chapter.]

All the drums were open at one end, while the other end had a bottom of metal, on which the monks beat with big leather clubs. Behind each instrument was a row of monks. The situation is demonstrated in the following diagram (see above.)

When the stone was in position the monk behind the small drum gave a signal to start the concert. The small drum had a very sharp sound, and could be heard even with the other instruments making a terrible din.

All the monks were singing and chanting a prayer, slowly increasing the tempo of this unbelievable noise. During the first four minutes nothing happened, then as the speed of the drumming and the noise increased, the big stone block started to rock and sway, and suddenly it took off into the air with an increasing speed in the direction of the platform in front of the cave hole 250 meters high.

After three minutes of ascent it landed on the platform. [Note: Pay attention to the fact that it took three minutes to rise 250 meters. We are not talking about a “cannonball ” effect. Slowly, the levity force overtook the gravity force and *the stone lazily rose into the air.*]

Continuously they brought new blocks to the meadow, and the monks using this method transported 5 to 6 blocks per hour on a parabolic flight track approximately 500 meters long and 250 meters high. From time to time a stone split, and the monks moved the split stones away. Quite an unbelievable task.

Dr. Jarl knew about the hurling of the stones. Tibetan experts like Linaver, Spalding and Huc had spoken about it, but they had never seen it. So Dr. Jarl was the first foreigner who had the opportunity to see this remarkable spectacle.

Because he had the opinion in the beginning that he was the victim of mass-psychosis, he made two films of the incident. The films showed exactly the same things that he had witnessed.

The English Society for which Dr. Jarl was working confiscated the two films and declared them classified. They will not be released until 1990. This action is rather hard to explain, or understand. : End of trans.'

[Note: And now we have the beginning of Cathie's comments:]

The fact that the films were immediately classified is not very hard to understand once the given measurements are transposed into their geometric equivalents.

It then becomes evident that the monks in Tibet are fully conversant with the laws governing the structure of matter, which the scientists in the modern day western world are now frantically exploring.

It appears, from the calculations, that the prayers being chanted by the monks did not have any direct bearing on the fact that the stones were levitated from the ground. The reaction was not initiated by the religious fervor of the group, but by the superior scientific knowledge held by the high priests.

The secret is in the geometric placement of the musical instruments in relation to the stones to be levitated, and the harmonic tuning of the drums and trumpets. The combined loud chanting of the priests, using their voices at a certain pitch and rhythm most probably adds to the combined effect, but the subject matter of the chant, I believe, would be of no consequence.

Cathie's work then goes into an explanation of how these measurements work very well with his own discoveries of the energy harmonics of Planet Earth, and Cathie's work has already been covered in *The Shift of the Ages*.

Cathie's findings point us directly towards the idea that the aether vibrates in harmonic resonance, and the vibrations can be measured very precisely and put into numbers. For now, what we should see is that this act of levitation is not a product of fantasy -- the entire setup was carefully observed, measured and yes, even filmed.

It took the stones three whole minutes to rise, so this was not simply a sudden catapulting effect; rather, it was more like a slow, deliberate movement.

### 8.9.1 SCIENTIFIC ANALYSIS OF TIBETAN ACOUSTIC LEVITATION

For those who are interested, an [article by Dan Davidson](#) helps us to put this amazing event into scientific terms. If the technical numbers and terms bother you, then simply skip past this excerpt and keep on reading, as it will not detract from your overall understanding of the concepts.

Monks with 19 musical instruments, consisting of 13 drums and five trumpets, were arranged in an arc of 90 degrees in front of the stone block. The instruments had the following measurements:

- 8 drums were 1 meter diameter x 1.5 meters deep x 3mm sheet iron and weighed 150 kg.
- 4 drums were 0.7 meter diameter x 1 meter deep
- 1 drum was 0.2 meter diameter x 0.3 meter deep
- All trumpets were 3.12 meters x 0.3 meters...

Calculations reveal that the volume of the large drums are similar to the stone block volume. The medium drums are one third the volume of the large drum and the small drum is a 41st of the medium drum and 125th of the large drum.

The exact volume of the large stone is not available; however, the harmonic relations of the drums implies it is about 1.5 cubic meters.

Another interesting aspect of this levitation demonstration is the small amount of power necessary to perform the levitation. The loudest tolerable sound pressure that a person can stand is approximately 280 dynes/cm<sup>2</sup>. From physics analysis this translates to about 0.000094 watts/cm<sup>2</sup>.

If we assume that each monk with his instrument produced one half this much sound energy (which is highly unlikely) and we make the further gross assumption that this is the amount of power that reaches the stone (actually sound dissipates rapidly over distance), we would have about 0.04 watts (i.e., (19 instruments + 19 x 4 monks) x 0.000094) hitting the huge stone block.

This is an astoundingly small amount of energy actually hitting the 1.5 cubic meter stone to produce the effect.

To lift the stone 250 meters takes a prodigious amount of energy. Rocks such as granite and limestone have weights in the neighborhood of 150-175 pounds per cubic foot.

If we assume a nominal value of 160 pounds per cubic foot then the 1.5 cubic meter stones weighed around 8475 pounds (i.e., over 4 tons!!!). To lift the 8475 pounds 250 meters would require about 7 million ft-pounds of work (i.e., 8475 pounds X 250 meters / 0.30408 meters/foot = 6,968,035).

Since this was done over a 3 minute period then about 70 horsepower was produced (i.e., 7 x 10<sup>6</sup> foot-pounds / 180 seconds / 550 horsepower/foot-pound/second = 70.384). This is equivalent to 52 kilowatts (i.e., 70.384 X 0.74570 kilowatts/horsepower = 52.5).

The over unity power factor we obtain is **5,250,000 over unity** (i.e., 52,500 watts/0.01 watts).

The monks were obviously tapping into a huge amount of free energy to levitate the huge stone blocks, or gravity requires little power to affect its operation once the principles are understood.

What Davidson missed in this analysis is that the "levity" force is already nearly as strong as the "gravity" force, so it isn't as hard to shift them as one might otherwise think.

Clearly, the entire arrangement was tailor-made to create waves of sound resonance that would reverberate within the stone to be moved, and absorb or reflect the downward-pressing force to create levitation.

If we look back at the shape of the monks with their trumpets, we can see that they formed exactly one quarter of a circle, with all their sound pressure directed at the "bowl" depression in the ground that the stone sat in.

Once the stone had reached a relatively pure level of sound resonance inside of itself, which took several minutes, a gateway for the aetheric energy to flow into our reality would be opened up, and a polarized spherical "consciousness unit" field would form around the object.

Then, like water drifting into a whirlpool, the gravity would simply absorb into stone without pushing it down to the Earth, while the weaker levity or “pressor ” force coming up from the Earth would win out, causing the stone to gradually rise. If you’ve ever seen a bubble of air slowly, slowly rise through a thick liquid, then you can see how these differences in pressure could create a slow levitating effect.

Furthermore, we remember that Cathie didn’t think that the chanting or concentration of the monks had anything to do with the final effect. However, the work that was displayed by gifted psychics such as Nina Kulagina helps us to see that the energy of consciousness, focused by the chanting and meditation, could certainly have been involved in the levitation.

It is possible that without the extra “kick ” of meditation to add more conscious energy to the mix and organize what was already forming there, this experiment could not be replicated. This dramatic display starts to make even more sense to us when we consider that the Tibetans might be the inheritors of a lost ancient aetheric science from an advanced technological society; and these topics were examined in *The Shift of the Ages*.

#### **8.10 KEELY’S LEVITATION OF A 4-TON IRON SPHERE**

Keely also appeared to have developed tools to interface acoustic or electromagnetic resonance with his own consciousness to produce the desired aetheric effects on physical matter, possibly changing the direction of “flow ” in the CU by conscious thought energy alone. The excerpt, also from Davidson’s article on the KeelyNet website that we just quoted, gives a concrete example of this that was seen by a witness.

##### Levitation of 4-Ton Iron Sphere:

After Keely’s untimely death in 1898, several investigators from the Scientific American magazine staff went to Keely’s laboratory looking for evidence to support the idea that Keely was a fraud.

They thought they found what they were looking for when they lifted the floorboards of a section of the laboratory and found a large cast iron sphere from which protruded pieces of iron pipe but the pipes were not connected to anything. The sphere was estimated to weigh 6,625 pounds and have a bursting strength of 28,000 pounds.

This event revived the charge that Keely had used compressed air to perform his miraculous feats; which, if true, would have earned Keely a fortune from compressed air inventions.

Research by a friend of mine uncovered a newspaper article [that was] written while Keely was still living, which tells the story of how the iron sphere got under the floorboards.

It seems that the newsman who wrote the article had gone to see Keely for possible newsworthy information. He found the inventor in his laboratory tearing a large hole in the floor. Keely greeted the reporter but did not seem to be in a talkative mood as he appeared quite busy.

After enlarging the hole, Keely attached a strange belt with several mechanisms built into it to his waist. He then attached a thin wire leading from the belt to a large sphere resting in the corner of the laboratory.



After a few minutes of intense concentration by Keely the ponderous globe slowly lifted a few inches from the floor. Keely then floated the iron sphere over the hole in the floorboards and allowed the huge mass to settle to the ground below the floor level.

After a few adjustments to the belt mechanism Keely again seemed lost in rapt concentration. This time the globe slowly but inexorably settled itself into the earth, buried by the opposite of levitation; namely, supergravity.

Keely had evidently caused the apparent mass of the sphere to increase to such an extent that it sank into the firm earth much as a heavy rock sinks into mud. The inventor told the reporter that he was making room in his lab by clearing away outmoded equipment.

It is theorized that the belt mechanism Keely wore during the levitation feat tuned the atomic structure of the iron sphere so all the atoms were synchronized and aetheric force directed through the sphere caused it to levitate or gravitate.

Once again, we can clearly see that consciousness did indeed appear to factor in directly to the levitation and / or gravitation, as it may have in the Tibetan case. Although the majority of the effect was most likely produced by some form of resonating electromagnetic energy, it certainly looks as if Keely's mental concentration was important in directing the movement of this energy.

He may or may not have actually moved the object with his hands to get it into position; the article only says that he "floated" it into position. The most interesting aspect of this case is that once again, it was witnessed by someone else and was therefore not simply hearsay.

### **8.11 SONOLUMINESCENCE**

Keely's work also involved the idea that when water was vibrated at certain frequencies, visible light would emerge within it. He tied this in with the properties of sound to harness the aetheric energies. This phenomenon has now been duplicated through an experiment that is known as "Sonoluminescence."

In this experiment, a spherical flask that is filled with water is vibrated at a certain frequency, low in pitch but very high in strength. In the below image we see a simple laboratory setup for this process, with the spherical flask in a clamp and high-intensity speakers mounted to either side of the sphere, with red power wires attached.

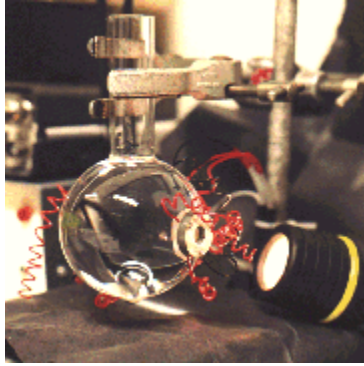

Photo from William Andrew Steer's laboratory research.

When the speakers are running, this arrangement causes a sonic force to be directed towards the exact center of the sphere that the flask makes. Then, the scientist must introduce an air bubble into the water and carefully try to manipulate it into the center that the sound forces are pressing towards. Once an air bubble is properly fixed into the center, the vibrations will allow it to stay there, and an amazing thing happens; it starts emitting light.

At first, the scientists studying this believed that the light was constant, but now it has been shown through delicate measurements to be pulsating at a very rapid speed. The next image below shows a much more high-tech setup, where the spherical flask is housed within a special apparatus that obscures most of the flask from view.

No conventional explanation for why this might be happening exists, and many scientists have tried to explain it in conventional models. The most popular idea is that the extreme forces of sound create nuclear fusion, thus leading to the humorous term "the Star in a Jar."

However, this flies completely in the face of the experiment itself, since the more that the water is cooled, the more light you get! By cooling the water, the amount of molecular vibration in it decreases, thus making it even easier for the sound vibrations to resonate purely.

Other conventional explanations for sonoluminescence sound equally absurd. However, we do know for a fact that the bubble inside shrinks significantly in size every time that a pulse of light is released, and this is occurring at extremely fast rates of speed. It is believed that this collapse creates such intense pressure that great energy is released, but the source of this energy remains a mystery to the mainstream.

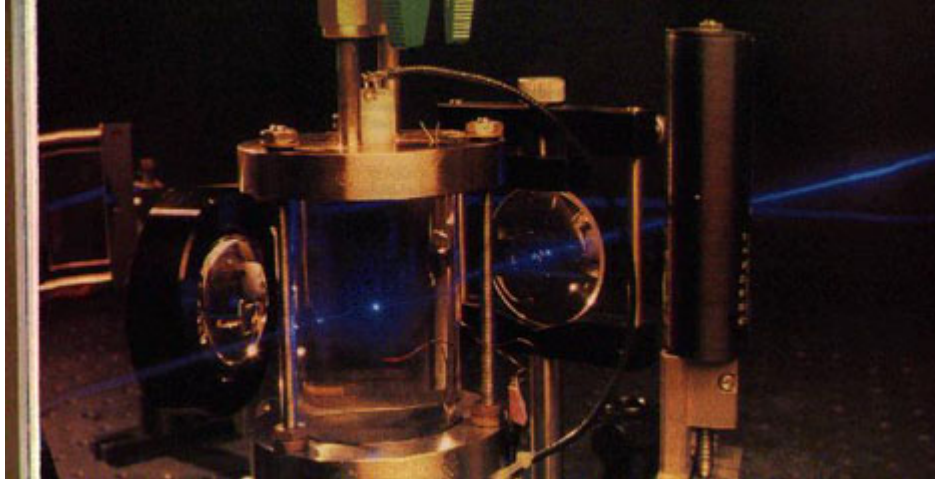

Photo from an article by Aaron Levinson.

Although John Keely mentioned this phenomenon in his own work, general credit is given to H. Frenzel and H. Schultes at the University of Cologne in 1934 as being the first to discover this. They were using very strong ultrasonic fields in water as part of their wartime research in marine acoustic radar.

Although they were not looking for or expecting such results, they discovered to their surprise that clouds of unpredictable and non-synchronous flashing bubbles of light were formed in the water in front of them. This is now known as "multi-bubble sonoluminescence" or MBSL.

Little was done to advance this study until 1988, when D. Felipe Gaitan was able to trap a single bubble at the center of a flask that was vibrating at its own acoustic resonance level, and sonoluminescence was then seen.

Once Gaitan accomplished this effect, he became rather disinterested in pursuing it further, and Dr. S. Putterman et al. subsequently picked it up at UCLA, California. It was Putterman et al.'s research that determined that the internal bubble compresses to 1 / 100,000th of its original size due to the pressure of the sound, during which time the light is released.

The flash of light is shorter than 100 picoseconds (or trillionths of a second) in duration, vibrating with extreme regularity every 100 millionths of a second. Putterman's studies eventually made it into Scientific American in February 1995, which dramatically increased public awareness and interest in the phenomenon.

An article excerpt from the Wall Street Journal on October 15, 1991 helps us to truly understand how significant this is:

...A photon of blue light given off by a single atom carries an energy of 3.5 electron volts. This is a trillion times more energy than any single atom in the tiny bubbles could have gained from the sound waves. He [Putterman] speculates that as each bubble implodes to about 1/100,000 of its original [size] volume, the energy and atoms in the bubble are concentrated to a tiny point.

The flash occurs when a million atoms simultaneously release this concentrated energy by giving off photons of blue light.

So, we can see that if we are producing a trillion times more energy than exists in the sound waves themselves in this experiment, then quite an incredible amount of energy is coming through from "nowhere." This is typically seen as a fusion reaction.

However, as we have already said, by concentrating sound waves in such a fashion as this we can open up a "gateway" for the high-pressured aetheric "fluid" to flow into our physical reality, forming light, heat and energy.

Furthermore, the shape of the sphere is very important in all of this, as it helps to centralize the vibrations. The Tibetan monks were in a 90-degree circular formation, exactly one-fourth the size of a complete circle. The sound waves would resonate outward into a partially spherical field that absorbed downward-moving gravity force, and since all the sound pressure was coming from one side, it might have made it easier for the levity force to push up the stone in the opposite direction.

The same logic applies to sonoluminescence. An article by William Andrew Steer, working in the undergraduate teaching laboratory in the Physics Department of University College London, reveals that:

**...the sphericity of the flask is very important.** If there is more than a millimeter difference between polar and equatorial diameters, then the resonance becomes very much broader and less strong, requiring more electrical drive to achieve the same sound intensity in the flask. [emphasis added]

## 8.12 SUMMARY

Remember that we started out the last chapter by discussing "glowing magnetism" and the "ball-of-light" theory. Once again, we come back to the sphere, and its harmonic structure. So, by now we should be able to see that there is a remarkable similarity between the spherical device that Schappeller used to focus electromagnetic energy into "glowing magnetism" and the spherical flask that focuses sound waves to produce "sonoluminescence," which appears to be exactly the same thing.

Both are showing us that "vacuum domains" or "consciousness units" can be directly visible through experiment, and that electromagnetic or light energy is not needed to create this effect. Almost all free-energy researchers agree that it is the background energy of the aether that is being harnessed in these reactions.

So, we have a lot to consider in this chapter. Normally outside of physical view, our reality is composed of an "aether" of pure Light that naturally assumes a spherical form. When the form is in motion, it becomes visible to us as a "photon," but when it remains in place as a "standing wave" it can form matter particles, ball lightning and possibly much larger bodies of energy as well.

Both Schappeller and Nordberg believe that all of matter that makes up our physical universe began as glowing magnetism, and most of the matter that we can see in the universe, namely the stars, galaxies, nebula, quasars and the like, still exist in this state at their cores.

Perhaps the physical matter that we see around us on Earth is more of a "cooled down" form of what originally started as glowing magnetism, which is still visible for us to see any time we go out and look at the stars, galaxies and heavenly bodies in the night sky.

### **8.13 RECAP**

**8.1** For our purposes in this chapter and thereafter, we will replace the unwieldy-sounding term "vacuum domains" with the simpler and more all-inclusive term "consciousness units" or CUs. This term is used to respect the fact that the energy of the universe displays regularized qualities of intelligence based on its level of vibration.

**8.2** Before all other free-energy researchers we discussed, there was John Ernst Worrell Keely, who performed amazing experiments that showed the connection between aetheric vibrations and sound. He also was not afraid to directly connect his energetic theories with the idea of an Ultimate Being and of the philosophy of love and light as the unifying force in the universe.

**8.3** Keely indicated that there were three main aetheric forces to deal with: push, pull and stabilize, or as he called them, "tractor," "pressor" and "dominant."

**8.3.1** What we interpret as "gravity" is the leftover force once the "up" and "down" energy movements have canceled each other out. Keely calls this point of balance the "dominant."

**8.3.2** There is indeed observational evidence to suggest that Keely's model of gravity is correct. If there wasn't a constant push-pull of gravity and levity moving between the Earth and the Moon and balancing their positions, they would have crashed into each other long ago.

The same is true for the Solar System, where the Sun contains 99.86% of the total mass and yet does not attract the planets into itself. Within the Earth, we now know that normal gravitational force, downwardly directed, is replaced by a reversed upwardly directed force at depths greater than 2,700 kilometers (1,678 miles.)

**8.4** If you can somehow absorb some of the downward-contracting gravitational force without absorbing the up-pressing "levity" force, then the Earth's levity will naturally push you away from its surface, thus creating anti-gravity. Within what we have called a polarized CU, the direction that the outside of the torus is rolling will determine which force it absorbs more of.

**8.5** The two spiraling vortices in the polarized CU will show counter-rotational movement, as this is a requirement for the outside to move in a uniform fashion. The exact center of the CU, therefore, is an area of "zero-spin energy transfer," where there is no rotation as the clockwise spiral transforms into the counter-clockwise spiral. A diagram from Dr. Richard LeFors Clark shows us how this appears in a bar magnet, and the central area is called a "Bloch Wall."

**8.6** John Keely named this area the "Neutral Center," and tied it in with a metaphysical concept. He believed that all matter, all aether, all Love, all Light, all Life, all the Universe ultimately emanates from this one single point of energy, which can be called God or The One. He also was able to manipulate the position of this center in an object and create anti-gravity and other effects as a result.

**8.7** Here we summarize the effects of the tractor, pressor and dominant forces, including the idea that as the tractor and pressor forces naturally balance in the “dominant ” or stabilizing force, this completes the cycle of matter creation or the “breath of life. ”

**8.8** By concentrating sound pulses directly into the center of an object, “ripples ” or “waves ” of vibration are created through the object itself, as well as in the aether that forms it. This can form the spherical torus of energy that we have covered in detail so far, leading to the anti-gravity effect without any direct use of electromagnetic fields. Keely demonstrated this principle with a flying craft, which was publicly flown before the United States War Department in 1896.

**8.9** Dr. Jarl from Sweden was the first foreigner on record to observe the ancient Tibetan practice of ‘acoustic levitation.’ Through a relatively simple setup involving drums and trumpets, giant stones were caused to slowly levitate in a parabolic pattern up to a cliff.

This effect is made possible by the qualities we have previously mentioned, and Dr. Jarl’s measurements revealed that all the trumpets and drums were precisely proportioned to the size of the levitating object. Though Dr. Jarl filmed this spectacle on two different occasions just to prove that it was real, the English Society for which Dr. Jarl was working confiscated the two films and declared them classified.

**8.9.1** Dan Davidson’s research reveals that the overunity power factor in the Tibetan Acoustic Levitation is 5,250,000 over unity (i.e., 52,500 watts/0.01 watts,) meaning that roughly 5,250,000 times more energy is being used to levitate the stones than is being directly emitted by the drums and trumpets. Bruce Cathie believes that this effect has nothing to do with consciousness, but it could well play a part, given what we know from the studies of Nina Kulagina and others in the laboratory setting.

**8.10** The idea of a consciousness connection to sound-based levitation processes is further supported by the observation of Keely levitating a four-ton iron sphere. A journalist came to his house and witnessed him wearing a small device attached to a belt with a metallic string coming out of it, which was then attached to the sphere.

By adjusting the belt settings and concentrating intensely, Keely was able to get the sphere to levitate, move across the room and then plunge into the ground with evidence of its weight having substantially increased.

**8.11** The phenomenon of “sonoluminescence ” shows that sound energy can produce a trillion times more energy than it naturally exerts in a special laboratory condition. A bubble is suspended in water in the center of a spherical flask by the use of directed sound fields.

Once the bubble is suspended, UCLA’s Dr. S. Putterman et al. determined that the internal bubble compresses to 1 / 100,000th of its original size due to the pressure of the sound, during which time light is released. The flash of light is shorter than 100 picoseconds (or trillionths of a second) in duration, vibrating with extreme regularity every 100 millionths of a second. Putterman’s studies eventually made it into Scientific American in February 1995.

# CHAPTER 09: VORTEXES, PROPULSION AND MATTER CHANGES

[Tweet](#)

## 9.1 OVERVIEW

In this chapter we will go even further to show the various anomalies that can be seen from the spiraling vortex energies of the polarized “consciousness unit,” (CU,) how they can be put to use, and their effects on the state of matter.

We will cover Dr. Dmitriev’s anomalous findings regarding tornadoes, the Oregon Vortex, (a natural Earth anomaly that displays all characteristics of a polarized CU,) and the work of Victor Schauberger using flowing water as a propulsion system.

Then we will segue into the next chapter, where we will discuss the deeper anomalies that have been seen in Earth energy vortexes such as the Bermuda Triangle, suggesting that higher-dimensional forces are somehow at work that can affect the passage of time as well.

## 9.2 DR. DMITRIEV AND “TORNADO PHYSICS”

In Dmitriev’s paper “Electrogravodynamic Concept of Tornadoes,” his knowledge of “vacuum domains” or what we have called “polarized consciousness units” is applied directly to the task of understanding how and why tornadoes work the way that they do.

As we have already said, a polarized consciousness unit is a sphere-shaped area of energy that has a hole through the center like a peeled orange. The tubelike area in the center has the fastest speed of movement and the most significant amount of energy, and it appears that in this area, gravity waves are directly transformed into electromagnetism and light; after all, these are simply different forms of on unified aetheric energy.

In Dmitriev’s paper there is extensive documentation to support these claims, and interested readers should refer back to the paper for more information, as this will only be a summary that does not provide the extensive references that are listed therein.

Most scientists who study tornadoes see them as miniaturized versions of cyclones or hurricanes. In a hurricane it is well-known that a zone of high air pressure and a zone of low air pressure come together and begin spinning around each other, creating an intense, rotating weather system that can cause great disturbances.

Similarly, in most cases a tornado is preceded by very dark, low-lying clouds that move at high speeds. So naturally, the conventional model simply agrees that the tornado’s energy and power emanates solely from its parent cloud and the movements that occur within that cloud.

The conventional mathematical model, originally proposed by E.M. Brooks in 1949, requires the parent cloud to be at least three times bigger than the funnel cloud, and to have at least three layers inside of itself, the first two of which are counter-rotating. The high pressure of rotation around a central axis causes the air to be forced closer to the center, similar to a spinning ice skater pulling in her arms and thereby increasing the speed of her spin.

For most, this model is unquestioned, and therefore this chapter might seem a waste of time or a gesture of scientific naïveté on our parts.

However, Dmitriev cites concrete evidence of cases where a funnel-cloud or waterspout appeared all by itself, without any clouds overhead! Furthermore, as the cloud continued swirling around, what appeared to be a parent cloud formed around it.

Now based on the information that we have already covered in this book, we have a means of explanation. A funnel cloud is actually the rotating central tube of a spherical torus of energy, which we have referred to as a polarized CU.

These energetic formations do not require cloud activity to be created, as Dmitriev's research shows that they can be formed by the Sun to move through space and impact our ionosphere as "Atmospheric Holes," they can form as "ball lightning" and can also emerge from the earth as "natural self-luminous formations" (NSLFs) or "radar angels." (See next image for a rare, photographed example of two NSLFs from Russia.)

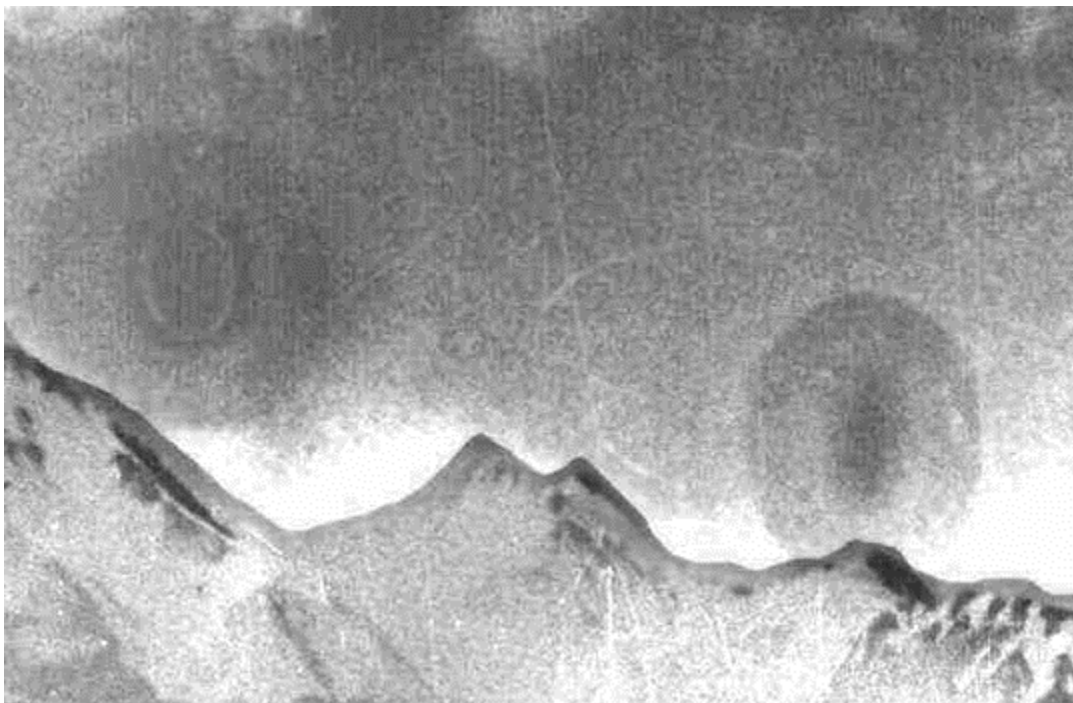

[Caption from <http://www.tmgnow.com/repository/planetary/pfvd.html>:



Pic.1. Largescale NSLF above the Katun' mountain ridge.

The image was made aboard a helicopter on Aug. 19, 1972 at 11. local time. The observers' attention was drawn by "whitish shining spots in the direction of Mt. Belukha summits".

Disk and oval shapes, so distinctly visible on the photo, were not observed visually. An estimate of the objects made using topographic charts of the region gives [them a diameter of] more than 1,5 km.]

So, in the cases where a tornado is seen to form without a parent cloud, what we have is an energetic process that has more to do with the movements beneath the Earth's surface than it does with the atmosphere.

Dust and particles are drawn up into the whirling winds to make the funnel visible. Then, the energy that had formed the funnel cloud subsequently attracted moisture from the atmosphere to itself, thus causing a "parent cloud" to form. However, to all conventional meteorological studies using the Brooks model, this is an impossible anomaly and must be discounted.

Dr. Dmitriev is not discounting the importance of atmospheric processes in tornado formation, but he insists that we're only seeing half of the equation if we do.

No one has been able to satisfactorily explain why tornadoes originate where they do, as only certain places on Earth will have them, and it seems to Dmitriev that the answer lies in the fluidlike convection processes of movement in the lithosphere, under the Earth's crust. Until we see this interface between "top and bottom," we won't truly understand what is at work here.

If we remember from Chapter Seven, Dmitriev et al. had listed the properties of a "vacuum domain," which we have called a "polarized consciousness unit," and a host of ten different anomalies were given to show this in action. We remember that these vacuum domains can penetrate matter, and that some of the anomalies involved these energies moving through the Earth, or up out of the Earth.

In particular, areas that are near earthquake faults have consistently given birth to NSLFs that have been observed, and when these formations rise higher into the sky they can be picked up by radar, and are then referred to as "radar angels." Modern equipment is built to weed out these false signals, but the "why" of their appearance is rarely mentioned.

### **9.2.1 UFO SIGHTINGS**

Since we do not understand or have a model for these luminous phenomena, they certainly could account for a fair percentage of reported UFO sightings of lights in the sky, even including their effects on electromagnetic equipment.

We are not citing this fact to try to discredit the many sightings that have had clear cases of metallic structure and other obvious signs of intelligent design. However, it is important for us to remember that our scientific study of these phenomena has long been seriously hampered by the overall media ban on any mention of UFO phenomena as being other than cases of "mass hysteria" or delusion.

For this very reason, there are volumes of good scientific data that could help us study these particular cases, and yet they are continually discounted.

So in Dmitriev's model, the true formation of a tornado is a combined interaction of forces that doesn't just involve the atmosphere; it originates from this energetic action between the various layers of the Earth, some in the atmosphere and some in the Earth itself.

When we start looking at the anomalies surrounding the tornado phenomenon more closely, we should start seeing that "all is not well" in the conventional model. It's hard to believe that we've had such a concrete example of true levitation in front of us for so long, and yet we still are stuck into thinking that it has only to do with air suction! The data simply doesn't support this concept.

### 9.2.2 HOLE-PUNCH CLOUDS

And for those who think that the above photo of natural self-luminous formations must somehow be "faked" and that there is no other evidence that supports this idea, the next photo should raise some new questions. In Melbourne, Florida in November of 2000, some unusual cloud formations appeared so outside of the "norm" that the National Weather Service gave them the impromptu new name of "hole-punch clouds." They literally look as if clear, perfectly round holes have been cut through a thin layer of clouds.

In the article at <http://www.floridatoday.com/news/columnists/larimer/111200larimer.htm>, several pictures of these formations are given, and we are also told that they were aligned with the Earth's magnetic field, in a north-south direction. A similar occurrence had been witnessed and documented there in 1993. The explanations given by the meteorologists seem to be quite a stretch in light of Dr. Dmitriev's research.

...the 'hole-punch' features were aligned north/south. This suggests that there was some sort of 'wave' in the atmosphere that was causing rising/sinking air couplets.

"This would cause ice crystals in the descending portion of the wave to fall into the super cooled (liquid) cloud layer. When this occurs, the ice crystals grow (at the expense of the liquid droplets). Therefore, a hole opened in the deck of cirrocumulus.

Given the evidence now at hand, instead of an inexplicable "wave" in the atmosphere that peculiarly "wants" to run north to south and plop perfect ovals into the clouds with "air couplets," it is far more likely that these are created by natural self-luminous formations, aligned with Earth's magnetic field, that have arisen from the underground tectonic processes that are occurring in that area.

Then, just as "radar angels" would do, they float up from the ground and create electromagnetic changes as they pass through the atmosphere. In this particular case, the cloud layer was thin and cold enough that the electromagnetic energy of the NSLF could ionize the clouds and thereby form the visible thin holes of ice crystals.

These cloud formations might be visible far more often if it were not for the fact that most clouds are thick enough to absorb the impact of the rising energies, then dispersing them without making a visible formation.

### 9.2.3 LUMINOUS TORNADO ANOMALIES

Bearing our suggested explanation for the “hole-punch cloud” phenomenon in mind, let’s again turn our focus back to the tornadoes, and in Dr. Dmitriev’s research we will clearly see how many problems there are that the current models do not address. We will begin by looking again at some of the key phrases from the many sightings of luminous phenomena in tornadoes that Dmitriev has compiled:

- a ball of fire in the funnel
- lightning in the funnel cloud
- a yellow shining surface on the funnel cloud
- incessant lightning surrounding the tornado
- a fiery column in the tornado
- glowing clouds surrounding the tornado
- a brilliant shine from the tornado
- a brilliant luminous cloud inside the funnel
- beaded lightning surrounding the tornado
- exploding fireballs associated with the tornado
- a rotating band of deep blue light in the funnel
- a “Fourth of July pinwheel” effect of light from the funnel

When we look at this list of properties it should be immediately apparent to us that there are massive amounts of “free energy” being created by tornadoes.

What Searl was able to harness with his Gyro Coils seems to pale in comparison to the amount of energy that would be required to produce such a constant amount of luminous phenomena. However, there are far more anomalies that we must keep in mind in order to fully understand the tornado phenomena for what it is.

### **9.3 TORNADO PHENOMENOLOGY**

So here, we will briefly cover the eight points mentioned in section 2.1 of Dmitriev’s paper, entitled “Tornado Phenomenology,” in order to get full coverage of the anomalies that must be considered when studying tornadoes.

#### **9.3.1 FUNNEL CLOUDS WITHOUT “PARENTS”**

In point number 1, evidence that works against the conventional Brooks model of tornado formation is cited, through case histories where a parent cloud did not appear to be responsible for forming a funnel cloud. In a case reported by H.B. Wobus, a funnel left a cloud and moved forward, and soon a new cloud formed above it, reaching 10 kilometers in height.

Then, for several hours after this new cloud was formed, intense lightning was seen within it. Of course, if meteorologists just choose to ignore this data, then everything is “fine” and the mistaken concepts can continue to be used without question.

Another interesting challenge to the Brooks tornado model comes from near Shanghai, China. While a person was out on a boat in the sea, the surface of the water near the boat suddenly began showing a spraying movement forming.

In a very short amount of time, the spray formed into a rotating column that was about ten meters wide and six meters tall. Imagine how frightening this would have been if you were the one on that boat! At this point the column began growing rapidly in its size. Even though no clouds had formed above the cyclone at first, a cloud did eventually develop, which grew dark in color.

So, in both of these cases, the funnel cloud did not seem to require a parent cloud in order to function. If we have no direct atmospheric cause for the funnel to form, then we really don't have much else to explain it with, other than the idea that it is an unseen energetic formation.

However, if the movements under the Earth produced a rotating burst of electro-gravitational energy that rose up and gathered up the water or atmosphere around it into its high-energy rotating central shaft, then everything begins to fit much more clearly.

### **9.3.2 HORIZONTAL TO VERTICAL MOVEMENT**

Point number 2 that Dmitriev raises is that no one has truly come up with a satisfactory explanation for how the horizontal movement in the clouds is suddenly transformed to form the thin, vertical movement of the funnel cloud.

When seen in the case of water going down a drain, we know that the drain is a "sink" that allows the water to flow down the hole with the force of gravity. Another way to simulate a tornado is to fill a clear glass jar  $\frac{3}{4}$  full with water and then put the lid on and whirl the jar around quickly in circles.

A tornado-like formation will indeed appear inside the water. However, this formation requires the pressure that is created by the glass walls of the jar, which extend from the top to the bottom of the funnel formation!

So in order for the tornado to be able to support its central shaft, it must either be exchanging energy with the Earth as a sink or having some form of outside energy pushing on it to hold its shape together. Obviously the spherical energy field of the polarized consciousness unit would be responsible for the pressure on the central shaft seen in the tornado, in this case.

### **9.3.3 LEVITATION EFFECTS NOT CAUSED BY AIR SUCTION**

In point number 3, Dmitriev begins by reminding us that clearly defined air walls can be seen inside of a funnel, and lightning will be seen to flash between them. Normally, the levitation effects associated with a tornado are thought to be solely a function of the vacuum of air inside. However, when a tornado is not in contact with the ground directly, no levitation effects are seen.

Here we refer back again to the case from Texas in 1951, where a whopping 130-meter wide funnel cloud with walls that were three meters thick passed over an observer at the scant height of six meters, which is essentially lower than the standard tree level. As the person looked up into the funnel, a brilliant cloud of light could be seen, and there was no vacuum of air being produced, as breathing was not a problem.

The walls had a very fast speed of rotation, and this movement could be observed all the way up to the top of the funnel itself. Shortly thereafter, the same funnel touched down onto a neighbor's house and immediately lifted it off of the ground.

Dr. Dmitriev explains that this is but one of many similar cases that prove that the levitation effect only occurs within the spiraling energy field of the tornado itself. He does remind us that measurements conducted in 1966 have proven that the air pressure inside the funnel cloud itself is low, but from the Texas data we know that beneath the funnel cloud, the air pressure is unchanged.

This again suggests that the energetic interactions that form a tornado are far more mysterious than we have been led to believe. The rotation and air suction appears to be self-contained within the cloud itself, not spreading away from it but rather maintaining its structure inside of the spherical energy field.

### **9.3.4 ANOMALOUS MATTER PHASE CHANGES**

In point number four, Dmitriev cites a whole host of anomalies that suggest that matter is capable of changing its basic form inside a tornado, becoming invisible and / or permeable to other matter. This point will actually become very central to our future discussions.

In the conventional models, these observations are typically explained by the scientific observation that inside the funnel cloud itself, the air is directed in a downwards motion at a high rate of speed, but then when you measure the walls of the cloud, the air is moving upward at about 100 to 200 meters per second.

In mainstream theories, this sudden reversal in the direction of air flow is conveniently used to explain many anomalous events that have occurred surrounding tornadoes. Dr. Dmitriev urges us to look more carefully and question whether the mundane explanation of opposing air flows could hold up in light of the following pieces of evidence.

These first few points focus on the idea that the effects of a tornado can be very sharply different in areas that are only a few meters from each other. This, of course, is in stark contrast to the widespread damage caused by hurricanes and other forms of extreme weather:

- A funnel uprooted an apple tree, tearing it to pieces. A beehive standing a few meters from the tree remained unharmed.
- A two-story timber house was taken off with its inhabitants and torn to pieces. A staircase of three stairs had led to the front door and had a bench leaning against it, and both the bench and staircase were not moved.
- This same funnel proceeded to tear off two wheels from a car standing by, without disturbing the rest of the car, and an oil lamp that was sitting nearby on a table underneath a tree was still burning.

Regarding the situation with the car, it would appear that the tornado's energy had somehow weakened the lug nuts that held the wheels onto the car and thus released them, while not damaging the rest of the vehicle.

If the metallic structure of the entire car had been weakened by the tornado's energy changes somehow, then the lug nuts simply gave way under the pressure, while the rest of the car was still able to resist coming apart. Certainly

skeptics could try to concoct other fanciful explanations for this, but as we proceed the facts will only continue to suggest that this is the correct interpretation.

Before finding Dmitriev's paper, we had heard a story from a firsthand witness where a tornado passed through a given area, and a piece of straw had somehow ended up being fused halfway through a plate-glass window with no signs of breakage; but unfortunately, no photographs were available.

Then, when discussing this topic with our friend Sabrina, she recounted stories that she had heard from a friend of hers in Oklahoma where a tornado had passed through, and part of the body of a cow had become fused into the wooden walls of the barn that it had been staying in. Since the effect was frighteningly fatal for the cow and the farmer did not want to attract attention or notoriety, this fact, like so many other similar tornado anomalies, was simply covered up.

How could such phenomena be possible? The only immediate explanation would be that in the area surrounding a tornado, there are distortions created in the "fabric" of space and time. Knowing what we now know about aetheric energy and its responsibility in creating matter, it would appear that in these cases that:

In the high-energy rotating fields of the tornado, matter is brought to a higher vibrational state where it temporarily changes phase and is able to pass through other matter.

Then, when the tornado passes by and the energetic effects wear off, the matter again reverts back to its normal state and solidifies.

Now while these stories were interesting, we had no other means to support them with documentation at first. Then, our attention turned to the Internet for research, and we uncovered [this website](#):

The Great Bend, Kansas tornado of November 1915 is the tornado which seems to have the greatest number of oddities associated with it... an iron water hydrant was found full of splinters...

Fictional oddities were added almost daily to the growing list of stories. An iron jug was blown inside out... a rooster was blown into a jug, with only its head sticking out of the neck of the container.

We can see here that the idea of an iron fire hydrant being able to "fill up" with splinters clearly violates the laws of physics. No matter how fast the splinters were traveling they should not have been able to penetrate metal.

However, if the normally solid matter of the hydrant had become flexible and permeable to other matter, then this could be easily explained. The other reports from Great Bend are immediately treated as fiction, such as the idea that an iron jug could be blown inside out.

However, both the hydrant and the jug are made of iron, a metal that is exceptionally responsive to magnetic fields, and we know from Dr. Dmitriev's work that there are very strong electromagnetic anomalies associated with tornadoes.

In the case of the jug reversing, it is possible that the tornado had somehow changed the matter state of the jug and made it as pliable as a sheet of rubber. Then, in the presence of low air pressure inside the funnel, the higher pressure inside the jug would suddenly blast out like a cannon, turning the jug inside out in the process.

This is an entirely predictable phenomenon to occur in the case of a thin, elastic material exploding in such a manner. Similarly, the rooster may have been blown into a jug that had become permeable to physical matter, and later stuck its head out of the jug to breathe and attempt to escape once the tornado had passed and the jug solidified.

As an interesting aside, we can also bring in the information that suggests that human beings are sometimes capable of producing the higher vibrational energies that can cause these changes in metal to occur. Radio talk show host Laura Lee features an article at her website, [www.lauralee.com](http://www.lauralee.com), where she writes about her experiences in going to a “spoonbending” seminar.

Of course, psychic Uri Geller was the first person to demonstrate and publicize this ability to bend metal in the 1970s, and in some cases he would appear on the radio and engage the audience in a collective metal-bending experiment. Numerous people, including small children, reported their astonishment at having achieved success in their own homes.

At the seminar attended by Laura Lee, the presenter was able to raise the energy and enthusiasm of the participants into a high level, at which time they were instructed to hold spoons or forks in their hand and bend them by concentration alone.

While Laura Lee did not personally succeed in bending a spoon, she witnessed one male participant holding a fork solely at its base and causing the tines to slowly droop and fold over, as though the fork was being melted under great heat.

In these cases, the temperature of the silverware does not raise anywhere near enough to allow true melting to occur, and the effect only lasts for a short time. However, during the five or ten seconds when the metal is actively pliable, the participants can bend and shape it any way they like.

Therefore, it would seem that the only other explanation is that certain, untapped forms of energy are capable of changing the molecular structure of matter, making it more pliable and permeable than would otherwise be possible.

We have already seen that it is possible for human beings to create such energy fields through the Russian research on telekinesis that was conducted with Kulagina, Vinogradova and Ermolayev. When we begin looking more seriously at these anomalous changes in physical matter, we may well discover that our contemporary quantum theories are in need of revision – and this will be covered in some detail as we progress.

Getting back to our original point, we can see that the human psychic effect on metal in “spoonbending” is seen on a much larger level in the energy fields of the tornado, involving other kinds of matter as well. If there were only an isolated number of these anomalies, then skeptics could quickly dismiss them all as hearsay.

However, once we discovered Dr. Dmitriev’s research, we found that he had cataloged a series of surprising facts in this area. In data that he cites from F.W. Lane in 1966 and T. Grazulis of Boulder, Colorado in 1993, we now have more anomalies to add to the list:

- A small pebble punctures a sheet of glass like a bullet, and does not form any fractures as it passes through.

- One board is seen to have penetrated another board without shattering it or causing any other visible damage; the two simply “fused together.”
- A burned and charred old wooden plank is seen to have punctured through the wall of a house made of timber. The weak, porous tip of the burnt plank was undamaged as it passed through the wall, even though it should have flaked apart very easily.
- A clover leaf was found to be pressed into a hard stucco wall deeply enough to form an indentation.
- A gate frame made from 1.5-inch thick sheet iron was found to be punctured by a stick of pine wood.

After looking at the facts, it seems almost ridiculous for mainstream researchers to conclude that all these effects could be created by nothing more than “high rotation speeds.” What we have is a clear violation of all known laws of physics! The only way that the clover leaf could have pressed into the stucco wall in such a manner would be if the wall itself had become as flexible and pliable as a liquid for a short time.

There is no possible way that boards could fuse together, a piece of pine wood could penetrate an inch and a half of solid metal, or a weak, charred plank could penetrate through the walls of a house without breaking, under the accepted laws of physics. Yet, if matter is becoming fluidlike and permeable as the tornado passes by, these become completely normal observations.

We see that in the presence of the powerful energies of the tornado, matter can actually make phase changes, and perhaps even disappear altogether from our known reality.

If we continue to believe that atoms and molecules are simply made of hard “particles” then this wouldn’t make much sense, but the new evidence that we will present suggests that atoms are simply electromagnetic fields of energy, and that energy ultimately is a measurable outcropping of the unseen, fluidlike “aether.”

In that case, atoms would certainly have more flexibility to change frequency. The Bermuda Triangle information will give us the proof that we need to see how this can happen.

### **9.3.5 WALLS WITHIN WALLS**

Point number five in Dmitriev’s list of tornado phenomena is that a circular vortex is often seen around the foot of a funnel cloud, forming a pillar of dust or water that rises and then falls to the earth, forming a cascade.

In some cases this cascade can be as high as 2/3rds of the funnel itself, and it can even be wider than the actual height of the funnel cloud. Since conventional theories of funnel-cloud formation have no explanation for this, it is simply ignored.

However, in many cases a funnel can be seen to have a second wall that entirely surrounds it, forming a collar or an envelope, and this second wall is also seen to rotate with high speed. And in rare cases, funnels have been seen to have a beadlike appearance to them, meaning that there are a series of spherical bulges in them instead of a smooth cone shape.

With the information that we have already surveyed in previous chapters, all of this data can be explained by the presence of spherical “vacuum domain” energetic forces. As we saw in the Roschin and Godin experiment, which



replicated Dr. Searl's results with the Searl Effect Generator, a spherical torus of ionizing radiation was formed and a series of low-temperature magnetic "walls" then surrounded it.

Therefore, the idea of "walls within walls" of nested energetic fields appears to be a normal byproduct of these energy fields. In these tornado cases, the additional "walls" are taking up dust or water and showing their visibility to a certain degree, and the bead-like bulges observed in the funnel could be smaller spherical energy fields that were moving through the larger field that had formed the tornado in the first place.

### **9.3.6 JUMPING MOVEMENTS**

Point number six is very short, namely that in almost all cases the funnel will only touch the ground at certain separate points and does not move in a slow, smooth path, but rather is seen to jump from one spot to another. This is most likely to occur when the tornado is first forming.

Again, we can clearly see that phenomena under the Earth's surface must be interacting with the energies in the tornado in some form in order for these effects to be seen.

### **9.3.7 GRAVITY / LEVITATION ANOMALIES**

Point number seven brings up another body of facts that strongly suggests that the tornado's levitation effects are due to an anti-gravity force instead of a suction force. As a funnel crosses over a river, it actually can produce a trench-like depression in the height of water on the river, as if an unseen force were pushing down on the water line and forcing it to flow in a clearly unnatural manner.

This was observed on both the Mississippi and Moscow rivers, as well as on the Rhine, where a trench that was seven meters deep had formed in an area where the total depth of the river was 25 meters.

Also listed in point number seven is the fact that people and animals can be lifted and transported distances as far as four to ten kilometers and sometimes be kept alive throughout the process. If they were constantly rotating at a high velocity inside the tornado, this would seem impossible, whereas if an anti-gravity field was holding them without rotating, this becomes far more plausible.

Similarly, in one case a series of one-inch mollusks were moved 160 kilometers and deposited on the ground in a small area, and the deposit occurred a full hour before the tornado cloud itself arrived. And on June 17, 1940 in the Meschery village of the region of Gorky in Russia, a tornado poured out about a thousand silver coins from the fourteenth century.

This was not a "time warp" as the original locations of the coins had been found; the important point was that *the coins fell in a very compact area after having been transported several kilometers, and they fell from the parent cloud but not the funnel itself.*

A tornado in Irving in 1879 encountered a 75-meter long railroad bridge that had just been constructed, weighing 108 tons. The tornado lifted the entire bridge and rolled it up – something that becomes much easier to understand when we consider the apparent ability of tornadoes to change the state of matter that they pass through.

The iron became as bendable as rubber, and the impressive forces inside the tornado could effortlessly twist it up, whereas normally we would expect the metal to bend only in certain weak places, or to simply fracture and break.

In another case, a funnel destroyed a large school building made out of stone, and the fragments rotated quickly inside of the tornado but were not thrown out. This obviously violates all expected laws of centrifugal force, showing again that a force exists inside the tornado that holds everything in place – something that cannot be explained by simple rotation and air suction.

In a similar case, a large timber church with 50 people inside of it was transported six meters and no one was killed. And in 1964, a funnel transported a house with ten people inside of it a distance of 400 meters, and all of them stayed alive.

### **9.3.8 ANOMALOUS ELECTROMAGNETIC EFFECTS**

Finally, point eight on Dmitriev's list of anomalies has already been covered, and it regards the electromagnetic properties of tornadoes that associate them most directly with "vacuum domains" or polarized consciousness units.

One fact is that when a tornado is not touching the ground, it has been observed to have a buzzing or hissing noise, which would be expected in the presence of powerful electromagnetic fields that are ionizing the atmosphere around themselves.

Tornadoes have been accompanied by the following, clearly electromagnetic effects: ball lightning, short and wide sheet lightning surrounding the funnel, a yellow glow that shines over the surface of the funnel, and bluish ball-like formations that are similar to ball lightning but on a much larger scale, which are seen inside the funnel cloud.

Obviously these larger spheres of blue energy are highly similar to the "natural self-luminous formations" that Dr. Dmitriev mentions elsewhere.

Slowly-moving fire columns have been seen as well, and H.L. Jones reported the formation of what he called a "pulse generator" before a tornado ever got started. In that case, thirty to ninety minutes before a funnel appeared from a parent cloud, a round, bright blue spot was observed inside the parent cloud and appeared to show signs of electric activity.

### **9.3.9 TECHNOLOGICAL APPLICATIONS OF TORNADO PHENOMENA**

So, with these facts in mind it shouldn't be difficult to see that tornadoes have a great number of energetic qualities and are by no means as simple to explain as most scientists would suggest. They are, quite literally, gigantic anti-gravity and free energy "machines" – the powerful, natural equivalent to the Searl Effect Generator and other such devices.

We should also keep in mind that the bizarre effects on the state of physical matter should also be able to be duplicated with technology as well, under the right conditions.

In cases such as the Bermuda Triangle, explained in the next chapter, we can see that the “next step” for matter, after it starts becoming elastic and able to fuse with other matter, is to disappear from our vibrational level or “reality” entirely; and this may lead to a valid science of teleportation.

As we explained in *The Shift of the Ages*, this is what appears to have happened by accident in the infamous “Philadelphia Experiment,” based on the work of Nikola Tesla.

In this controversial “experiment,” a series of high-intensity electromagnetic coils were designed to create a pulsating, spherical field around a ship, in the hopes of creating total visual and radar invisibility.

While the device was being tested, some of the men walked around the ship while in the state where they could permeate other matter, and when the ship re-solidified they were tragically fused into the metal walls of the ship itself. The reality of this experiment was confirmed by Army whistleblower Col. Phillip Corso prior to his death, although he claimed that the actual ship was the Navy minesweeper IX-97, and did not involve the USS Eldridge nor its crew.

In the next chapter, we will cite many more examples of possible technological applications of such “vortex” technology.

#### **9.3.10 VACUUM DOMAINS AS BETTER EXPLANATION**

At this point in his paper, Dr. Dmitriev begins bringing in his research findings regarding “vacuum domains” and natural self-luminous formations, which we are already familiar with from previous chapters. We are again reminded that these formations are seen to abruptly rise in frequency during times when the solar activity reaches its peak.

We are also told that when luminous formations are seen to arise from the ground in higher frequencies, such as in the area surrounding Altai Mountain in Gorny, there is a corresponding decrease in the amount of seismic activity in the area.

This certainly suggests that some of the stress that is normally relieved by the Earth with earthquakes can also be drawn out of the Earth in times of high solar activity. The natural self-luminous formations that are released then display the anomalous, highly energetic properties that we have already mentioned in previous chapters.

#### **9.4 THE OREGON VORTEX: A SPHERICAL TORUS OF EARTH ENERGY**

As we can see from Dr. Dmitriev’s research, there is clearly an interface between the inner processes of the Earth, the outer atmosphere and the energetics from the Sun that is responsible for natural self-luminous formations and tornadoes.

In the course of his research, Dmitriev also reports on various magnetic anomalies on the Earth’s surface that support this idea. On January 25, 2001, the Oregon Vortex, which is the United States’ most popular area for anomalies of this type, was again thrust into popular view when Nick Nelson appeared on the “Coast to Coast AM” show, then hosted by Dr. Mike Siegel.

Mr. Nelson has served as a tour guide to this vortex since 1999, is the author of a book entitled "The Golden Vortex," and currently has a [website](#).

The Oregon Vortex has been scientifically studied numerous times, with its peculiar behaviors repeatedly verified. In this sense we are quite blessed to have an active source where these energies can be studied and measured, the location and observation of which has not been suppressed, subverted or hidden from the public in any way.

We have already covered this story in *The Shift of the Ages* by describing the coverage that it was given in the prestigious scientific journal "*Compressed Air*," and will therefore restrict our inquiry to the new observations that were disclosed on the program, many of which we were not previously aware of. Some of these discoveries were made by Nelson himself as he took the time he spent in the vortex to make more careful investigations:

1. The Oregon vortex is spherical in shape. This conforms perfectly to what we would expect of a "vacuum domain."
2. The center of the vortex has a chimney-like movement of energy which lifts into the air. This shows that the field is actually a spherical torus, and it possesses a faster energy movement through its central axis than it does in the other areas, as we would expect.
3. The energy in certain areas has spiraling qualities. In a certain spot, a magnetized pendulum will spiral in circles, and if a person tries to stand in this area, their body will naturally be compelled to sway in circles as well. And we already have seen the importance of rotation in the polarized CU.
4. The vortex exhibits very strong electromagnetic effects. Movie cameras are not permitted in the House of Mystery (the name of the site built on the vortex,) ostensibly because the intense electromagnetic energies can cause permanent damage to sensitive equipment.
5. Clear, anomalous changes in gravity are seen in the vortex. In one area, a circle is drawn on the ground, and the closer you get to the circle the more you will be forced to lean, at about 7 degrees of arc off of true perpendicular. If you try to stand up straight, you will fall over.  
  
In another area, a broom can be stood up on its edge and remain standing for up to 36 hours. At another spot, a ball can be released on a slide and "roll uphill." All of these facts perfectly conform to the idea that a polarized CU causes noticeable distortions in the field of gravity, by altering the natural gravity-levity balance.
6. The vortex possesses clear magnetic sheets of demarcation. We have already seen this observation of "spheres within spheres" in action with the tornado phenomenon as well as in Roschin and Godin's replication of the Searl Effect in the laboratory.
7. The center of the sphere of energy is in the Earth. This correlates very well with our expectations that these energy processes can be created by areas under the Earth's surface where the fluidlike material of the lithosphere is flowing rapidly in a vortex-like fashion. A more detailed study of the underground geology in this area should reveal such a current.

8. The size of objects actually changes from one area to another inside the vortex. This is clearly visible to eyewitness observers and in photographs. Two men of equal height can walk to two different areas in the vortex, and depending on where they stand, one will clearly seem to be taller and the other clearly shorter. If they switch their positions, each spot will still show the same effects on their respective heights, so that the short man is now the tall man and vice versa.

Again, this conforms with our observations from tornado phenomena that suggest that definite effects on matter are being produced, which can change its overall structure in heretofore-unknown ways.

9 The changing size of objects cannot be measured with instruments. This is simply due to the fact that the measuring instruments also change in size as they move through these areas. Thus, “all is relative” within the vortex, making accurate measurements of the changes impossible, except by visual observation.

10. In the vortex, *the passage of time changes by a quarter-second*. Since Einstein proposed that space and time are unified as a single “fabric,” any changes in the quality of space should also change in time.

Our understanding of time has a new definition in the aether model; it is directly related to the speed at which the aether vibrates. We will have much more to say about this when we discuss our new theories of time, but for now we will move on.

11. The center of the vortex has a corona that is one-sixth the size of the sphere itself. Again, this conforms very nicely with Dr. Dmitriev’s findings, and is clearly visible in the photographs of natural self-luminous formations at the beginning of this chapter.

12. The normal speed of gravitational acceleration is lowered in the vortex. Normally, gravity propagates itself at 32 feet per second, whereas inside the vortex it slows down to 29.16 feet per second. This means that the overall downward effect of the gravity-levity balance in the formation is reduced by ten percent. This is identical to the manmade gravitational effects that were seen in the Searl Effect Generator on a much more significant level.

13. The human aura can become visible to everyone inside the vortex, at times, when a person stands in certain areas. This suggests that a person’s own magnetic or bio-electric field is amplified by the energies in the vortex. Once again, we are seeing how human beings fundamentally interact with these forces.

14. The vortex provides healing effects in certain areas. Mr. Nelson reported that he has an ongoing problem with severe back pain. By going and sitting in a certain area of the vortex, his pain would be healed in a matter of minutes. This correlates perfectly with Dr. Searl’s results in healing the severe burn wounds to his face with his Searl Effect Generator that was operating to power his house.

So, when all the facts surrounding the Oregon Vortex are considered together, we have a remarkable correlation with the other research that we have already discussed. Nick Nelson did not indicate on the program that he had

awareness of the many other ways in which this energetic structure has been seen, other than the fact that it closely resembles the magnetic field that is seen to form around a bar magnet.

(However, his book does cover other phenomena that are associated, including tornadoes and the structure of the galaxy.)

So ultimately, we find that by locating an anomaly that is 'half in and half out' of the Earth, we can make a clear bridge between the processes in the lithosphere, such as "kimberlite pipe explosions," and the energetic forms released into the atmosphere such as NSLFs, "radar angels" and tornadoes, and clearly see that they work in tandem.

Every single observed aspect of the Oregon Vortex should be expected to occur, based on the research that we have been investigating.

## **9.5 VORTEX PROPULSION OF VIKTOR SCHAUBERGER**

Once again, in the work of Viktor Schauburger we have yet another case where a person discovered the bizarre anti-gravitational effects that could be seen as a byproduct of rotation. We have already suggested that anomalies like the Oregon Vortex may be caused by the quick-moving flow of molten fluids under the Earth's crust, in the lithosphere, and ultimately by the luminous aetheric energy in the Earth's core, as we will see in Chapter 11.

In Schauburger's case, similar effects were discovered by his study and comprehension of the anomalies associated with flowing water, specifically the spiraling vortices that can be formed in a stream.

Olof Alexandersson wrote a book in 1982 entitled *Living Water – Viktor Schauburger and the Secrets of Natural Energy* from Turnstone Press in Wellingsborough, England, and most other writing on Schauburger's life and technological inventions draws directly from this source. Another frequently cited book is *Living Energies* by Callum Coats.

From the "Living Water" book, we learn that Schauburger first realized that an anti-gravity effect was occurring in flowing water by observing the behaviors of trout that were migrating upstream. He realized that in a waterfall, the coldest area will usually be in the center, and at this point the water will have a spiraling vortex quality.

The trout naturally seek these colder, spiraling areas at the center of the waterfall, and then with very little effort they will be seen to swim or levitate directly up the waterfall and be able to continue on upstream. Schauburger realized that something very peculiar was going on, and this led him to investigate the principles of spiraling, vorticular movement in water on a much deeper level.

When he used a stressed gravity detector to measure the amount of gravitational force inside the center of a waterfall, he discovered that it would either measure zero gravity or even less, which would obviously be the manifestation of the anti-gravity effect.

Eventually, he was able to use these principles to create a number of valuable inventions, including a system of half-pipe shaped "flumes" that used thin sheets of water to convey huge logs down a mountain. This discovery was a surprise and delight for those in the logging industry he was working for, who had thought it impossible for such a small layer of water to support that much weight.

The inside of the flumes were carved to have many layers of rings that would rise and fall in height by design, and the water would get trapped in between the cracks of the rings and provide support for the logs as they traveled along.

Schauberger also invented new designs for hydroelectric turbines that harness the natural power of spiraling movement in water to produce a much higher amount of electricity from a much smaller and more environmentally friendly turbine. The [work of Frank Germano](#) is an excellent resource in this regard, complete with volumes of technical data, and makes another good step in the direction of creating true “free energy” machines.

Schauberger also discovered that in certain high-speed vortexes of water that he observed in streams in the dark of night, visible light was produced. He was then able to duplicate the conditions with a special arrangement of rocks and flowing water and show the effect to his friends, which certainly created a source of amazement for them.

While this seems patently ridiculous at first, the chances are that unlike Schauburger himself, none of us have ever actually tried to observe something like this. Providing that Schauburger and his friends are indeed telling the truth, then this phenomenon does again fit perfectly with our expectations.

What we should see here is that under the right circumstances, the flowing vortex in the center of a stream of water can form the central axis for a polarized CU to form, just as is seen in the tornado. And then, as the observations of tornadoes and other such vortices suggests, a luminous phenomena becomes visible.

For our purposes the most interesting fact is that Schauburger’s observations of water eventually led him to allegedly produce workable anti-gravity machines that used water turbines for propulsion. Since his observation of the trout fish going up the waterfalls was how he originally discovered the anti-gravity force, he named his machines the German equivalent of “trout fish.”

If you hadn’t already guessed, the photographs and evidence makes it clear that in Schauburger’s system, the machine pumped the water into the form of a rotating spherical torus. And once again, the anti-gravity effect was harnessed through a very similar method, though realized in another form that we may not have otherwise considered!

This design was incorporated by Nazi Germany into apparently workable craft, essentially against Schauburger’s will. It seems that he was not allowed to disclose exactly how these prototypes were built, so he was forced to invent other designs for levitation that used simpler methods. He moved to the deserts of Texas to design his “Repulsine” machine, which sucked in bursts of air into a sealed, round chamber to form “smoke ring” or toroidal formations.

These bursts of air were then rolled into very small sizes as they traveled over and down the inside edges of the toroidal chamber. This compression would cause extremely cold temperatures to form in a tube that ran through the center of the device, which then caused the hotter, high-pressure desert air to rush into the low-pressure zone in the tube at a very fast speed. Then, this rushing airflow would drive a turbine fan at the top.

Some attempts have been made to reproduce the Repulsine craft by James L B Bailey at [jbailey@rectec.net](mailto:jbailey@rectec.net) , and his work can be easily found on an Internet site owned by JL Naudin at [Jnaudin509@aol.com](mailto:Jnaudin509@aol.com) [Jnaudin509@aol.com](mailto:Jnaudin509@aol.com) , but our main interest here is in Schauburger’s earlier closed-system water turbine that produced anti-gravity.

A [group in Denmark](#) is attempting to replicate these discoveries. Many interesting facts about Schauburger’s life and research can be found there. Here’s another [site of good quality on Schauburger](#).

Our main reason for discussing Schauberger's work at this point in the chapter is for us to see that the rotation of a fluid can directly produce anti-gravity; this gives even more evidence to suggest that the movements of a spinning vortex can have very powerful and heretofore unrecognized energetic effects.

In his writings, Schauberger refers to two forces of nature, an "explosion" force and an "implosion" force. He believed that our scientists had well understood the harnessing of energy by explosion, which he felt was a process that led to heat, pressure, fragmentation, illness and death.

The natural force of implosion, or centripetal, spiraling movement towards the center, was believed by him to represent the natural life-generating force of coolness, suction growth and healthiness in the universe, and this is what he built his machines to harness.

Furthermore, he was well aware of the balance between gravity and levity, and his own name for the levity force was "diamagnetism." This can be a bit confusing, as his ideas of diamagnetism are associated directly with a force that works off of conventional magnetism, but the underlying concepts appear to be the same.

Now that we have taken a quick glance at some of Schauberger's data, we are ready to move into our next topic area, where we will focus on the anomalies of the Bermuda Triangle.

Here, we will find a wonderful summary statement of all the various phenomena that we have already covered in this and previous chapters, including matter phase shifting, and we will also uncover other pieces of data that will open up the doors to our next set of chapters, where we will discuss the connections between higher dimensions, aether vibrations and geometry.

For those who have already read *The Shift of the Ages*, this will be a move into familiar territory, although we will ultimately suggest to new readers that this current book be studied first, since it is a far more linear, all-inclusive and syllogistic, step-by-step presentation that builds up the case.

## **9.6 RECAP**

**9.1** The content of the chapter is introduced, which includes tornado phenomena, the work of Victor Schauberger and the Oregon Vortex, an ongoing, unmoving space-time anomaly which has been scientifically studied on numerous occasions.

**9.2** Dr. Alexey Dmitriev's concepts of tornado physics and natural self-luminous formations involve an interaction between Earth's atmosphere and the interior of the Earth. The Brooks model of tornado formation, commonly used by meteorologists and other scientists alike, does not provide a model to account for the tornado anomalies that are seen.

**9.2.1** Many cases of alleged UFO sightings may actually involve natural self-luminous formations that are released from the Earth, as expected in the new systems of physics that Dmitriev has outlined.

**9.2.2** "Hole-punch clouds" appear to be another example of invisible NSLFs interacting with a thin layer in the atmosphere, forming visible "holes" that were aligned with the Earth's magnetic field. Had the cloud layer been thicker, these effects would most likely not have been visible.



**9.2.3** Many tornado sightings involve luminous phenomena, suggesting that tornadoes are actually sources of very high electromagnetic energy.

**9.3** Dmitriev's list of tornado phenomenology is shared at this point:

**9.3.1** Tornadoes have been seen to leave the so-called "parent" clouds over them and move on their own. They have also been seen to form without parent clouds at all, only attracting them later on. This suggests again that tornadoes cannot be solely related to atmospheric movements.

**9.3.2** Dmitriev explains that the Brooks model does not account for why a horizontal counter-rotational movement in cloud layers is suddenly able to turn into a vertical movement in the funnel cloud.

**9.3.3** The levitation effects of a tornado cannot be caused by the suction of air inside of the funnel cloud. When a tornado is just slightly above the ground, no air pressure changes are felt and no levitation effects are seen, but as soon as it touches the ground the levitation begins. The area inside the funnel cloud has been measured to have a lower air pressure, but this does not occur beneath the cloud.

**9.3.4** Inside the powerful energetic fields of a tornado, matter is seen to make sudden, anomalous phase changes, becoming malleable like a fluid and semi-permeable, allowing solid objects to fuse together. Once the tornado passes, the matter reverts back to its normal "ground" state.

In the case of "spoonbending," human beings seem to be able to temporarily duplicate these effects on metal with their consciousness. Conventional explanations for the anomalies of matter changes in tornadoes usually involve the observation that the inside of the funnel cloud has a rapid downward movement, whereas the walls of the cloud have a rapid upward movement at about 100 to 200 meters per second.

**9.3.5** "Walls within walls" of "spherical cascades" are often seen around tornadoes, sometimes going as high as two-thirds of the height of the funnel cloud itself. This energetic phenomena has already been seen in the Roschin / Godin replication of the Searl Effect in the laboratory.

**9.3.6** Funnel clouds are seen to travel over the surface of the earth in jumping movements, again suggesting that other forces besides atmospheric phenomena are associated with them; namely, an energetic interaction with the interior of the Earth.

**9.3.7** As tornadoes pass over rivers, they have been seen to create bowl-like depressions in the water line, suggesting that they are sources of powerful, anomalous gravitation. Tornadoes can transport objects, groups of objects and even living creatures over long distances without disturbing them. This again suggests that the transport of a tornado is being caused by levitation, not by suction and rotation.

**9.3.8** Tornadoes have been observed to have buzzing or hissing noises when they are not touching the ground, again indicating very high levels of electrostatic charge. Many types of luminous phenomena have been associated with tornadoes as well, suggesting that ionization is occurring around them. One case in particular involved a pulsating blue light that appeared in the air prior to the formation of a tornado.

**9.3.9** The anomalies of the tornado make a strong suggestion that technological applications are indeed possible, which will be discussed more in the next chapter. One possible example is the Philadelphia Experiment, confirmed as authentic by the late Col. Phillip Corso, who claimed that it was actually a Navy minesweeper and not the USS Eldridge, which was chosen as a cover story.

**9.3.10** Dr. Dmitriev's concept of "vacuum domains" as an explanation for tornado phenomena seems to fit much more closely with the data. We are reminded that in times when the solar activity reaches its peak, there is a corresponding increase in the amount of natural self-luminous formations that are sighted.

Furthermore, when natural self-luminous formations are seen over a seismically active area, there is a corresponding decrease in the amount of earthquake activity. This suggests that the NSLFs are releasing tectonic stress in the earth that would otherwise be forming earthquakes, by converting it into energy.

**9.4** The Oregon Vortex, covered in Nick Nelson's book "The Golden Vortex," shows all the classic signs of Dr. Dmitriev's "vacuum domains" and more:

- 1) It is spherical in form,
- 2) it has a chimney-like central vortex area,
- 3) its energy has spiraling qualities,
- 4) anomalous electromagnetic effects are seen,
- 5) changes in gravitation are reported,
- 6) it has clear magnetic sheets of demarcation,
- 7) the center of the sphere is in the Earth,
- 8) changes in the size of objects have been reported,
- 9) the size changes cannot be measured with instruments, since they also change in size,
- 10) the passage of time changes by a quarter-second inside the vortex,
- 11) the center of the vortex has a corona that is one-sixth of its total size,
- 12) the acceleration speed of gravity changes from 32 feet per second squared to 29.86 feet per second squared,
- 13) the human aura can become visible to everyone in the vortex, and
- 14) the vortex can provide healing effects.

**9.5** The work of Victor Schauberger appears to be yet another example of a working anti-gravity propulsion device being created through spherical-torus vortex motion.

By observing various anomalies of flowing water, including the levitation of trout fish through cold, central areas of a waterfall and observing areas of streams that naturally exhibit luminous phenomena from vortex water movement, Schauberger was able to devise his new ideas for anti-gravity propulsion. In this case, the energy is driven by the high-speed rotation of water in a toroidal form.

